

OFFICE OF FACILITIES MANAGEMENT SCOPE OF SERVICES

Project Name: Sheriff's Vehicle Maintenance Fan

Address: 1925 McDonald Ave. Eustis, FL 32726

Project Manager: Don Glessner

Unless otherwise noted, the Contractor shall provide all required labor, material, equipment, plans, engineering, permitting and local and state inspections to provide 100% turnkey project. Change orders shall not be issued for incidental items or tasks that should have been reasonably construed to be part of the project by the Contractor.

1. PURPOSE

- A. The purpose of this solicitation is to select a vendor to provide (2) Big Ass Fan COOL-SPACE® 500s.

2. SCOPE OF WORK

- A. Provide (2) Big Ass Fan COOL-SPACE® 500s per specification sheet. Lake County is tax exempt.

COOL-SPACE® 500

When you need maximum cooling coverage, trust the powerful performance of Cool-Space 500. Durably engineered with a portable design, quiet and efficient motor, and advanced controls for convenient, hands-free use, Cool-Space 500 delivers lasting comfort to large spaces both indoors and out. Backed by the industry's best warranty, it's the ultimate solution in evaporative cooling.



KEY FEATURES

- ▶ Quickly cool indoor and outdoor spaces by up to 33 °F (18 °C)
- ▶ Ideal for large warehouses, service bays, and stadiums
- ▶ 8-inch (20-centimeter) resin-treated cooling media
- ▶ 50-inch (127-centimeter) fan diameter
- ▶ 64-gallon (242-liter) reservoir lasts up to 10 hours without hose connection
- ▶ Onboard LED control panel with occupancy sensor

COVERAGE AREA

UP TO 6,500 SQUARE FEET
(600 SQUARE METERS)

AIRFLOW

UP TO 24,000 CFM

CONTROL

VARIABLE SPEED

VOLTAGE

**110 VAC
OR
230 VAC**



BIG ASS FANS®

**EXCEPTIONALLY
ENGINEERED**

DISCOVER MORE ABOUT COOL-SPACE

Learn more at bigassfans.com/evaporative-coolers
or call **877.BIG.FANS** for a free custom quote.

COOL-SPACE® 500

DELIVER COOLER CONDITIONS AT A MOMENT'S NOTICE

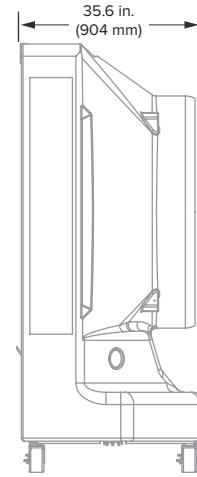
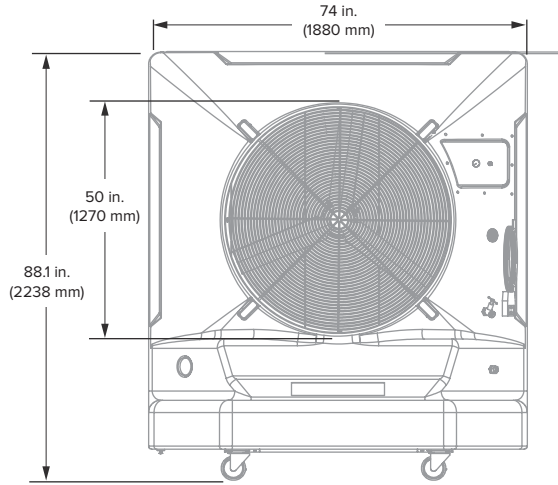

Technical Specifications

Model	Ordering Information	Weight	Water Capacity	Inlet Water Supply Pressure	Input power and required breaker	Environment ¹	Amperage ²	Airflow and Coverage	Sound Level ³	Operating Temperature
Cool-Space 500	F-EV1-5001 F-EV1-5002	370 lb (167.8 kg)	64 gal (242 L)	120 PSI maximum	120 VAC, 60 Hz, 1Φ, 25 A 220/230 VAC, 50/60 Hz, 1Φ, 15 A	Well-ventilated Indoor or outdoor space	16.5 A 8.6 A	16,500–24,000 cfm 6,500 sq ft	60 dBA	0 to 104 °F (-18 to 40 °C)

Construction

Housing	Motor	Controls	Power Supply	Water Supply	Cooling Media	Maintenance
UV-resistant roto-molded polyethylene housing Four locking swivel casters	Variable speed, high-efficiency, totally enclosed 1.5 hp (1.1 kW)	Remote control Onboard control panel Occupancy sensor	10 ft (3 m) power cord plugs into standard electrical outlet Cord wrap for easy storage	Accepts standard garden hose or portable supply tank Water level regulated by float valve Low-water shutoff for pump longevity	Made from 8 in. (203 mm) thick cross-corrugated formulated cellulose Treated with thermosetting resin for strength and prevention of algae	Accessible reservoir cap for convenient water treatment Drain plug and flush valve for water removal



Control Options



Remote Control



Onboard Control Panel

Onboard Control Indicators



Power Indicator



Low Water Indicator



Manual Fan Control



Occupancy Sensor



Manual Pump Control



Timer (15 Minutes)

¹ Not suitable for salt air environments.

² Maximum amperage includes both the fan and pump ratings.

³ Fans are sound tested in a laboratory environment. Actual results in field conditions may vary due to sound reflecting surfaces and environmental conditions.

Lead times may vary. See full warranty for coverage information.



USA
BIGASSFANS.COM
877-244-3267

CANADA
BIGASSFANS.COM
844-924-4277

AUSTRALIA
BIGASSFANS.COM/AU
1300 244 277

SINGAPORE
BIGASSFANS.COM/SG
65 6709 8500

MALAYSIA
BIGASSFANS.COM/SG
603 5565 0888



Consumer's Certificate of Exemption

DR-14
R. 01/18

Issued Pursuant to Chapter 212, Florida Statutes

85-8013874700C-1	09/30/2022	09/30/2027	COUNTY GOVERNMENT
Certificate Number	Effective Date	Expiration Date	Exemption Category

This certifies that

LAKE COUNTY BOARD OF
COUNTY COMMISSIONERS
315 W MAIN ST
TAVARES FL 32778-3813

is exempt from the payment of Florida sales and use tax on real property rented, transient rental property rented, tangible personal property purchased or rented, or services purchased.



Important Information for Exempt Organizations

DR-14
R. 01/18

1. You must provide all vendors and suppliers with an exemption certificate before making tax-exempt purchases. See Rule 12A-1.038, Florida Administrative Code (F.A.C.).
2. Your *Consumer's Certificate of Exemption* is to be used solely by your organization for your organization's customary nonprofit activities.
3. Purchases made by an individual on behalf of the organization are taxable, even if the individual will be reimbursed by the organization.
4. This exemption applies only to purchases your organization makes. The sale or lease to others of tangible personal property, sleeping accommodations, or other real property is taxable. Your organization must register, and collect and remit sales and use tax on such taxable transactions. Note: Churches are exempt from this requirement except when they are the lessor of real property (Rule 12A-1.070, F.A.C.).
5. It is a criminal offense to fraudulently present this certificate to evade the payment of sales tax. Under no circumstances should this certificate be used for the personal benefit of any individual. Violators will be liable for payment of the sales tax plus a penalty of 200% of the tax, and may be subject to conviction of a third-degree felony. Any violation will require the revocation of this certificate.
6. If you have questions about your exemption certificate, please call Taxpayer Services at 850-488-6800. The mailing address is PO Box 6480, Tallahassee, FL 32314-6480.