

**BOARD OF COUNTY COMMISSIONERS  
LAKE COUNTY, FLORIDA  
OFFICE OF THE COUNTY MANAGER  
AGENDA ITEM COVER SHEET**

---

**DATE:** 07/18/2024

**TO:** Jennifer Barker, County Manager

**THRU:**

Roberto Bonilla, Executive Director, Parks & Water Resources

**BY:** Bill Ponko, Senior Contracting Officer

**SUBJECT:** Ferndale Preserve Observation Deck, Fishing Pier, & Canoe Launch

---

**MEETING DATE:**

8/27/2024

**ITEM TYPE:** Consent Item

**ITEM ID:** 4685

**RECOMMENDATION/REQUIRED ACTION:** Approve

Recommend approval: 1. Of Contract 24-925 with Rush Marine, LLC (Titusville, FL) for the Ferndale Preserve Observation Deck, Fishing Pier, and Canoe Launch Project.  
2. To authorize the Office of Procurement Services to execute all supporting documentation.

The estimated fiscal impact is \$3,153,688 - \$800,000 (revenue/expenditure - grant funded) and \$2,353,688 (expenditure - county) and will not exceed available funding in the fiscal year budget. Commission District 3.

**BACKGROUND SUMMARY:** The Office of Procurement Services, in coordination with the Office of Parks and Water Resources, issued Invitation to Bid 24-925 for the 100% turnkey installation of the Ferndale Preserve Observation Deck, Fishing Pier, and Canoe Launch Project located at 19220 CR 455, Ferndale, FL, 34715. Ferndale Preserve is located on the western shore of Lake Apopka and is a 192-acre conservation and restoration area consisting of upland and wetland ecosystems. Ferndale Preserve was purchased in 2005 for \$4,155,000 with the assistance of a Florida Communities Trust (FCT) grant and support from the Lake County Board of County Commissioners, St. Johns River Water Management District and Lake County Water Authority.

The project consists of furnishing and installing a turn-key observation deck/fishing pier & canoe/kayak launch, an aluminum gangway and floating dock with canoe/kayak launch, including transfer station, furnishing and installation of fire extinguishers with cabinet, installation of precast concrete piles, precast concrete deck, solar-powered LED light fixtures, installation of floating turbidity barrier with weighted skirts and temporary signs. The proposed project is consistent with the requirements of the FCT grant.

Per the Army Corps of Engineering, the Contractor is required to provide the services of a professional archaeologist who meets the "Archeology and Historic Preservation: Secretary of Interior's Standards and Guidelines." The archaeologist shall be onsite

**AGREEMENT BETWEEN  
LAKE COUNTY, FLORIDA, AND  
RUSH MARINE, LLC FOR THE  
FERNDALE PRESERVE OBSERVATION TOWER, PIER, AND CANOE LAUNCH PROJECT  
(ARPA FUNDED)**

**ITB # 24-925**

This is an Agreement between Lake County, Florida, a political subdivision of the State of Florida (the COUNTY), by and through its Board of County Commissioners, and RUSH Marine, LLC, a Florida limited liability company authorized to conduct business in the state of Florida, its successors and/or assigns (the CONTRACTOR) (each a "Party" and collectively the "Parties").

**WITNESSETH:**

**WHEREAS**, the COUNTY publicly submitted an Invitation to Bid (ITB) #24-925 seeking firms or individuals qualified to provide construction services for the turn-key construction of an observation tower, pier, and canoe launch at the Ferndale Preserve property, located at 19220 County Road 445, Clermont, Florida 34715(Alternate Key No. 1590540 / PID 26-21-26-0003-000-00100); and

**WHEREAS**, the CONTRACTOR desires to perform such services subject to the terms of this Agreement; and

**WHEREAS**, the provision of such services will benefit the parties and the residents of Lake County, Florida.

**NOW, THEREFORE, IN CONSIDERATION** of the mutual terms, understandings, conditions, promises, covenants, and payment set forth in this Agreement, and intending to be legally bound, the parties hereby agree as follows:

**ARTICLE 1. LEGAL FINDINGS.**

**1.1** The foregoing recitals are hereby adopted as legislative findings of the Board of County Commissioners and are ratified and confirmed as being true and correct and are hereby made a specific part of this Agreement upon adoption hereof.

**ARTICLE 2. PURPOSE.**

**2.1** Purpose. The purpose of this Agreement is for the CONTRACTOR to provide 100% turnkey construction services for the construction of an observation tower, fishing pier, and canoe launch at the Ferndale Preserve, as more fully described herein (the "Service" or "Project").

**ARTICLE 3. SCOPE OF SERVICES**

**3.1** On the terms and conditions set forth in this Agreement, the COUNTY hereby engages the CONTRACTOR to provide all labor, materials, and equipment to complete the Service in accordance with the Scope of Services, including all addenda, and the completed Submittal Form, attached hereto and incorporated herein as **Composite Exhibit A**. It is understood that the Scope of Services may be modified by change order as the Service progresses, but to be effective and binding, any such change order must be in writing, executed by the parties, and in accordance with the COUNTY'S Purchasing Policies and

Procedures. A copy of these policies and procedures will be made available to the CONTRACTOR upon request.

3.2 The Service consists of the 100% turnkey construction services for the construction of an observation tower, fishing pier, and canoe launch at the Ferndale Preserve. The Service must be scheduled and constructed in a manner which allows park operations to continue outside the Project area while site improvements are completed. The Service shall include the Base Bid Item #1 as well as the Base Bid Item #2 (Professional Archeologist), as described in **Composite Exhibit A**.

3.3 The parties acknowledge that this is a project specific agreement and **that the single Service shall not exceed two hundred seventy-three (273) days from the date the Notice to Proceed is issued.**

3.4 This Agreement will become effective upon both parties signing this Agreement (the "Effective Date"). The Service will commence upon issuance of the Notice to Proceed by the COUNTY to the CONTRACTOR following the Effective Date.

3.5 This Agreement shall remain in effect until such time as the services acquired in conjunction with the Service and this Agreement have been delivered and accepted by the COUNTY. The terms and conditions of this Agreement shall remain in effect until completion of all express- and implied-warranty periods. The COUNTY reserves the right to negotiate for additional services/items similar in nature not known at the time of solicitation.

3.6 All work must be performed in accordance with good commercial practice. The work schedule and completion dates must be adhered to by the CONTRACTOR except in such cases where the completion date will be delayed due to acts of God, strikes, or other causes beyond the control of the CONTRACTOR. In these cases, the CONTRACTOR shall notify the COUNTY of the delays in advance of the original completion date so that a revised delivery schedule can be appropriately considered by the COUNTY. Generally, no additional days will be granted to the CONTRACTOR for rain delays; however, CONTRACTOR may request in writing for the COUNTY consider an adjustment of the contract period on a case-by-case basis to account for delays caused by the effects of inclement weather events but only when such an event causes the CONTRACTOR to be able to work less than fifty percent (50%) of a scheduled work day and only when such delays are not the result of CONTRACTOR'S failure to perform or neglect. CONTRACTOR must strictly comply with all claim submission requirements and other requirements of the Contract Documents related to time extensions. No additional compensation will be made for delays caused by or related to the effects of weather.

3.7 The CONTRACTOR will be solely responsible for obtaining all necessary approvals and permits to complete the Service.

3.8 CONTRACTOR is responsible for obtaining an NPDES Construction Generic Permit from FDEP and shall be solely responsible for ensuring compliance thereunder, including the development of a Stormwater Pollution Prevention Plan, maintenance of erosion and sediment control BMPs, performance of required inspections, and recordkeeping requirements.

3.9 The CONTRACTOR acknowledges that it has sufficient understanding of the nature and location of the work; the general and local conditions including, but not limited to, those bearing upon transportation, disposal, handling and storage of materials; availability of labor, water, electric power, and roads; and uncertainties of weather or similar physical conditions at the site; the character of equipment and facilities needed preliminary to and during the completion of the Service. The CONTRACTOR further acknowledges that the CONTRACTOR has satisfied itself as to the character, quality and quantity of surface and

subsurface materials, obstacles, and conditions of the site. Any failure by the CONTRACTOR to acquaint itself with any aspect of the work or with any of the applicable conditions will not relieve the CONTRACTOR from responsibility for adequately evaluating the difficulty or cost of successfully performing the work required, nor will it be considered a basis for any claim for additional time or compensation. The COUNTY assumes no responsibility for any conclusions or interpretations made by the CONTRACTOR on the basis of the information made available by the COUNTY. The COUNTY also assumes no responsibility for any understanding or representations made by its officers or agents during or prior to the execution of this Agreement, unless such understanding or interpretations are made in writing and incorporated in this Agreement by reference.

**3.10** In the event any conflict between any drawings and specifications contained within this Agreement, the following will govern:

A. Addenda will supersede all other contract documents to the extent specified in the addenda. Subsequent addenda will supersede prior addenda only to the extent specified in subsequent addenda.

B. 100% plans will supersede earlier versions of plans incorporated herein without further action by the parties. Final approved plans, stamped by the permitting authority, supersede earlier versions of plans without further action of the parties.

**3.11** Plans and Specifications. The construction plans and specifications provided in the solicitation process are specifically incorporated herein as **Composite Exhibit C** and included by reference as a material term and condition of this Agreement. The Service shall be rendered in strict conformity with the construction plans and specifications, including any plans and specifications developed or provided by CONTRACTOR and approved by COUNTY as part of this Service. If applicable, any 100% plans or specifications provided by COUNTY shall supersede the documents listed below without the need for amendment to this Agreement.

A. **Composite Exhibit C** includes the following:

1. *Ferndale Preserve Observation Tower / Fishing Pier and Canoe / Kayak Launch Construction Plans*, dated May 2022, prepared by Halff Associates, Inc., for Lake County (28 pages). **[PORTIONS ARE EXEMPT PER SEC. 119.071(3)(b), FLA. STAT.]**
2. *Ferndale Preserve Observation Tower / Fishing Pier and Canoe/Kayak Launch Supplemental Specifications*, dated May 6, 2022, prepared by Powell Studio Architecture for Lake County (89 pages). **[EXEMPT PER SEC. 119.071(3)(b), FLA. STAT.]**
3. *013302 Shop Drawings for Specialty Engineered Products*, provided as Exhibit L to Addendum No. 1 of the Solicitation (1 page).
4. *Clarification on Required Materials*, provided as Exhibit O to Addendum No. 4 of the Solicitation (1 page).
5. *Geotechnical Investigation Report, Proposed Ferndale Preserve Observation Tower / Fishing Pier and Canoe / Kayak Launch, Lake Apopka, Florida*, dated February 21, 2022, prepared by Andreyev Engineering, Inc., for Lake County (61 pages).

6. *U.S. Army Corps of Engineers (ACOE) Letter of Permission for the Lake County / Ferndale Preserve Fishing Pier, Kayak Launch, and Observational Platform / 19220 CR 455, File No. SAJ-2012-01172, issued November 17, 2023 (67 pages).*
7. *Florida Department of Environmental Protection (FDEP) Consolidated Environmental Resource Permit and Sovereignty Submerged Lands Authorization for Ferndale Preserve Fishing Pier, No. 0421812-001-EI, issued June 17, 2022 (31 pages).*

**3.12 Parking, Storage, and Transport of Materials.** Due to the location of the project on the Ferndale Preserve along the shore of Lake Apopka, locations for material and equipment storage and provisions for the transport of materials, equipment and crews to the site are strictly limited to prevent adverse environmental impacts. CONTRACTOR shall closely coordinate logistics with the COUNTY. The COUNTY has provided CONTRACTOR with minimum guidelines regarding access to the site; see, *Clarification on Launching, Parking and Storage*, provided as Exhibit N to Addendum No. 4 of the Solicitation, attached hereto and incorporated herein as **Exhibit D**. CONTRACTOR understands that the Montverde Boat Ramp, located at the terminus of Abrams Avenue, is an unimproved access to Lake Apopka in a residential area owned by the Town of Montverde, Florida. CONTRACTOR is solely responsible for maintaining safe access and use of the ramp during the course of the Service and shall be responsible for any repairs necessary to maintain safe access and use of the ramp caused by CONTRACTOR'S use; such repairs will be made at no additional cost to the COUNTY and at the COUNTY'S discretion. CONTRACTOR'S use of the ramp shall not cause impacts to wetlands or water quality; if sediment or erosion control BMPs are required in the area, CONTRACTOR shall coordinate with COUNTY regarding placement and type. If CONTRACTOR'S misuse of the Montverde ramp results in a loss of access through the Town of Montverde, the CONTRACTOR shall be responsible for all additional costs incurred related to securing necessary access to finish the Service in a timely manner.

**3.13 E-Verify.** The CONTRACTOR shall utilize the U.S. Department of Homeland Security's E-Verify system in accordance with the terms governing use of the system to confirm the employment eligibility of all new persons hired by the CONTRACTOR during the term of this Agreement.

The CONTRACTOR shall include in all contracts with subcontractors performing work pursuant to any contract arising from this Agreement an express requirement that the subcontractors utilize the U.S. Department of Homeland Security's E-Verify system in accordance with the terms governing use of the system to confirm the employment eligibility of all new employees hired by the subcontractors during the term of the contract.

#### **ARTICLE 4. PAYMENT.**

**4.1** The COUNTY shall pay, and the CONTRACTOR shall accept as full and complete payment for the timely and complete performance of its obligations under this Agreement, as provided in the Pricing Schedule which is attached and incorporated by reference as **Exhibit B**. The total cost of the Project will not exceed **Three Million One Hundred Fifty-Three Thousand Six Hundred Eighty-Eight and 00/100 Dollars (\$3,153,688.00)**. Retainage shall be released as set forth in Section 218.735, Florida Statutes.

A fixed lump sum price represents the CONTRACTOR'S base bid, including all applicable taxes, materials, labor, tools, equipment, supervision, transportation, fuel, permits, inspections, licenses, management and overhead, and all incidentals necessary to provide a complete, turn-key Service, unless a duly authorized change order has been issued in accordance with the COUNTY'S purchasing policies and procedures.

Any hourly rate quoted will be deemed to provide full compensation to the CONTRACTOR for labor, supervision, equipment use, travel time, and all other costs associated with providing the services needed to satisfactorily complete all work provided. This rate is assumed to be at straight-time for all labor, except as otherwise noted.

**4.2** Retainage. A retention of funds equal to five percent (5%) will be withheld from each invoice in accordance with Section 218.735, Florida Statutes. Retainage will be released in accordance with Section 218.735, Florida Statutes, and as provided in Article 6.15 of this Agreement.

**4.3** Invoicing. The CONTRACTOR will submit invoices to the COUNTY no later than the thirtieth (30th) day beyond the date the work was completed and accepted by the COUNTY. Invoices are to be submitted to the to the Office of Parks & Trails at [parksinvoices@lakecountyfl.gov](mailto:parksinvoices@lakecountyfl.gov), unless directed otherwise by the Project Manager. Under no circumstances shall the invoices be submitted to COUNTY in advance of the delivery and acceptance of the work. All invoices shall be accompanied by PDF documentation of the work completed and invoiced, including, but not limited to: service tickets, suppliers' invoices, purchase orders, time sheets, approved proposals, and any other pertinent backup documentation requested by the COUNTY in COUNTY'S discretion. All invoices must contain the solicitation number, date and location of delivery or service, purchase order number, confirmation of acceptance of the goods or services by the appropriate COUNTY representative, and a detailed description of services provided, and a calculation for the five percent (5%) retainage to be withheld.

**4.4** Progress Payments. The CONTRACTOR may receive periodic payments on a thirty (30) day interval for Service tasks completed during that period by the CONTRACTOR and approved by the COUNTY'S Project Manager. Retention of funds will be held in accordance with Section 218.735, Florida Statutes. In order for the COUNTY to provide payment, the CONTRACTOR shall submit a fully documented invoice that provides the basic information set forth below. Each invoice must contain such detail and be backed up with whatever supporting information the COUNTY or the CONTRACTOR reasonably requests and must at a minimum state:

- A. The total Construction Price for the Service.
- B. The amount due for properly provided labor, materials and equipment properly incorporated into the Service; and with respect to amounts invoiced for materials or equipment necessary for the Service and properly stored at the Site (or elsewhere if offsite storage is approved in writing by the COUNTY), be accompanied by written proof that the COUNTY has title to such materials or equipment and that such material and equipment is fully insured against loss or damage.
- C. A breakdown of the various parts of the Service as related to the Pricing Sheet as shown on **Exhibit B**.
- D. The value of the various parts of the Service performed;
- E. Previously invoiced amounts and credit payments made;
- F. The total amount due, less any agreed retainage;
- G. Submit a current schedule with every pay application; and
- H. A lien waiver and other documentation verifying the CONTRACTOR'S payment to subcontractors and suppliers as the COUNTY may reasonably request.

I. Include CONTRACTOR'S Payment Affidavit, attached hereto and incorporated herein as part of **Composite Exhibit E**.

Without limitation, at any stage of the Service, the COUNTY may require that the CONTRACTOR provide a lien release executed by the CONTRACTOR and each subcontractor having provided Notice to COUNTY and any other subcontractor, Laborer, Materialman or person or entity providing labor, materials or services as may reasonably be required by the COUNTY which such release and waiver of lien must relate to the work which is the subject of the Application for Payment.

4.5 The COUNTY shall make payment on all undisputed invoices in accordance with the Florida Prompt Payment Act, Part VII, Chapter 218, Florida Statutes. The COUNTY will not make payment on partial delivery of supplies, services, or materials.

4.6 In the event any part of this Agreement or the Service, is to be funded by Federal, State, or other local agency monies, the CONTRACTOR hereby agrees to cooperate with the COUNTY in order to assure compliance with all requirements of the funding entity applicable to the use of the monies, including providing access to and the right to examine relevant documents related to the Service and as specifically required by the Federal or State granting agency, and receiving no payment until all required forms are completed and submitted. A copy of the requirements will be supplied to the CONTRACTOR by the COUNTY upon request.

4.7 Payment/Performance Bond Requirements. Pursuant to Florida Statutes, Section 255.05, CONTRACTOR must provide a Performance and Payment Bond or irrevocable letter of credit in an amount that represents **100%** of the contract price. The Performance and Payment Bond Form supplied by the COUNTY will be the only acceptable form for these bonds. No other form will be accepted. Bond information and forms are attached hereto and incorporated herein as **Exhibit F**. In the event the CONTRACTOR defaults on the construction, the COUNTY shall utilize the Payment and Performance bond or letter of credit to complete the work.

4.8 Payment Procedures.

A. The COUNTY will review the CONTRACTOR'S applications for payment, including such accompanying data, information and schedules as the Service requires, to determine the amounts due to the CONTRACTOR and, based upon such review, together with its inspections of the Service, will authorize payment by the COUNTY to the CONTRACTOR in writing. Such authorization will constitute the CONTRACTOR'S certification to the COUNTY that:

1. The Service described in the CONTRACTOR'S invoice has progressed to the level indicated;
2. The Service has been performed in accordance with the Agreement;
3. All necessary and appropriate lien waivers have been submitted; and
4. The amount requested is currently due and owing to the CONTRACTOR.

B. In the case of unit price work, the CONTRACTOR'S recommendations for payment will constitute final determination of quantities and classifications of such work.

C. Payments will be deemed timely if postmarked on or before the payment date defined in this Agreement or any other payment due date stated in this Article 4.

D. COUNTY may withhold all or part of an application for payment to the extent reasonably necessary to protect the COUNTY if in the COUNTY'S opinion the representations to the COUNTY required by this section cannot be made. If the COUNTY is unable to certify payment in the amount of the application, the COUNTY will notify the CONTRACTOR as provided for in this Agreement. If the CONTRACTOR and the COUNTY cannot agree on a revised amount, the COUNTY will promptly authorize payment for the amount which the CONTRACTOR is able to make such representations to the COUNTY. The COUNTY may also withhold payment or, because of subsequently discovered evidence, may nullify the whole or part of an application for payment previously issued, to such extent as may be necessary in the COUNTY'S opinion to protect the COUNTY from loss for which the CONTRACTOR is responsible, including loss resulting from its acts and omissions, because of:

1. Defective Work not remedied;
2. Third party claims filed or reasonable evidence indicating probable filing of such claims unless security acceptable to the COUNTY is provided by the CONTRACTOR;
3. Failure of the CONTRACTOR to make payments properly to subcontractors for labor, materials, or equipment;
4. Reasonable evidence that the Service cannot be completed for the unpaid balance of the contract price;
5. Damage to the COUNTY or other CONTRACTOR;
6. Reasonable evidence that the Service will not be completed within dates established in this Agreement, and that the unpaid balance would not be adequate to cover liquidated damages for the anticipated delay; or
7. Persistent failure to carry out the Service in accordance with this Agreement.

**4.9 County's Right to Refuse Payment.** The COUNTY'S approval of the CONTRACTOR'S invoice will not preclude the COUNTY from exercising any of its remedies under this Agreement. These remedies include, without limitation the COUNTY'S right to withhold all or part of any payment (including Final Payment) for the reasons described in Article 4. In the event of a dispute, payment will be made on or before the payment date for amounts not in dispute, subject to any setoffs claimed by the COUNTY. The COUNTY will have the right to refuse to make payment and, if necessary, may demand the return of a portion or all the amount previously paid to the CONTRACTOR to the extent due to:

A. The CONTRACTOR'S failure to perform the Work in compliance with the requirements of this Agreement or any other agreement between the parties.

B. The CONTRACTOR'S failure to correctly and accurately represent the Service performed in a payment request, or otherwise.

C. The CONTRACTOR'S performance of the Service at a rate or in a manner that, in the COUNTY'S reasonable opinion, is likely to result in the Service being inexcusably delayed.



**D.** The CONTRACTOR'S failure to use funds previously paid the COUNTY, to pay the CONTRACTOR'S Service-related obligations including, but not limited to, the CONTRACTOR'S subcontractors, materialmen, and suppliers.

**E.** Claims made against the COUNTY or its property.

**F.** Loss caused by the CONTRACTOR'S subcontractors, or suppliers and not paid by insurance or covered by bonds provided by CONTRACTOR.

**G.** The CONTRACTOR'S failure or refusal to perform any of its obligations to the COUNTY.

**4.10** Contractor's Right to Refuse Performance for Non-Payment. If within the time set forth in Section 218.735, Florida Statutes, the COUNTY, without cause or basis under this Agreement, fails to pay the CONTRACTOR any amounts then due and payable to the CONTRACTOR will have the right, in addition to all other rights and remedies contained in this Agreement, to send the COUNTY an overdue notice. If the payment request is not rejected within four (4) business days after delivery of the overdue notice, the payment request or invoice shall be deemed accepted, except for any portion of the payment request or invoice that is fraudulent or misleading.

**4.11** Correction of Past Payments. All prior payments, whether based on estimates or otherwise, may be corrected and adjusted in any subsequent payment and will be corrected and adjusted in the final payment. If any invoice contains a defect or impropriety which would prevent payment by the payment date, the COUNTY shall notify the CONTRACTOR in writing of such defect or impropriety in accordance with Section 218.735, Florida Statutes. Any disputed amounts determined by the COUNTY to be payable to the CONTRACTOR will be due in the time frames set forth in Section 218.735, Florida Statutes, from the date the dispute is resolved.

**4.12** Interest on Outstanding Amounts Due. To the extent allowed by Chapter 218, Florida Statutes, interest will accrue on amounts owed by the COUNTY to the CONTRACTOR which remain unpaid for the time specified in the statutes. CONTRACTOR must invoice COUNTY for any interest accrued in order to receive the interest payment.

No interest will accrue when payment is delayed because of a dispute between the COUNTY and the CONTRACTOR, or a dispute as to the accuracy or completeness of any request for payment received. This exception to the accrual of interest will apply only to that portion of a delayed payment which is the subject of the dispute and will apply only for the duration of such disagreement.

**4.13** Invoice Warranties and Guarantees. The CONTRACTOR expressly warrants and guarantees to the COUNTY that:

**A.** Title to all goods, products, materials, equipment, and systems covered by an invoice will pass to the COUNTY either by incorporation into the Service, or upon receipt of payment by the CONTRACTOR, whichever occurs last.

**B.** All goods, products, materials, equipment, and systems covered by an invoice are free and clear of liens, claims, security interests or encumbrances.

**C.** No goods, products, materials, equipment, or systems covered by an invoice have been acquired by the CONTRACTOR, or its subcontractors or suppliers, subject to an agreement under which

an interest or an encumbrance is retained by the seller or otherwise imposed by the CONTRACTOR, or its subcontractors or suppliers.

**4.14 Contractor's Signature.** The signature of the CONTRACTOR on any invoice constitutes the CONTRACTOR'S certification to the COUNTY that (i) the CONTRACTOR'S services listed in the invoice have progressed to the level indicated and have been performed as required by this Agreement; (ii) the CONTRACTOR has paid its subcontractors and suppliers their proportional share of all previous payments received from the COUNTY; and (iii) the amount requested is currently due and owing.

**4.15 Taxes.** The CONTRACTOR shall incorporate into the Pricing Sheet, and pay, all sales, consumer, use and similar taxes for goods, products, materials, equipment, and systems incorporated into the Service which were legally required at the time of execution of this Agreement, whether yet effective or merely scheduled to go into effect. The CONTRACTOR shall secure, defend, protect, hold harmless, and indemnify the COUNTY from and against all liability, loss, claims, demands, suits, costs, fees and expenses (including actual fees and expenses of attorneys, expert witnesses, and other consultants) relating to any taxes assessed or imposed upon, incurred by or asserted against the COUNTY by any taxing authority with respect to such taxes. The CONTRACTOR shall cooperate with and assist the COUNTY in securing qualified refunds of any sales or use tax paid by the COUNTY or CONTRACTOR on goods, products, materials, equipment, or systems. Any refund secured must be paid to the COUNTY.

**4.16 Sales Tax Recovery Program.** In accordance with Section 212.08(6), Florida Statutes, and Rule 12A-1.094, Florida Administrative Code, the COUNTY is tax exempt when it purchases tangible personal property for use in public works projects, subject to certain restrictions. In the event this project is declared a sales tax recovery project by the COUNTY, the following procedures will apply:

**A.** The COUNTY, through its Project Manager, shall determine whether the COUNTY will directly purchase certain materials required for the Work.

**B.** If requested by the Project Manager, the CONTRACTOR shall prepare a list of proposed items that may be desirable for COUNTY direct purchasing. Proposed items will be items that are purchased in a single order from a single vendor with a value greater than \$10,000. Upon reviewing this list, the COUNTY will determine whether it will directly purchase certain materials. The COUNTY shall notify the CONTRACTOR in writing of the specific materials which are intended to be purchased.

**C.** Within ten (10) calendar days from receipt of the written notice described in Article 4.16.B, the CONTRACTOR shall advise the COUNTY in writing of: (a) the date upon which the materials must be on-site according to the construction schedule approved at that time, (b) the date that the CONTRACTOR directs that the COUNTY place the order for the described materials, (c) the location to which the materials are to be delivered, and (d) any other particular details of the order which the CONTRACTOR requests that the COUNTY include in the Purchase Order to the vendor.

**D.** The COUNTY may, but is not required to, provide the CONTRACTOR with the proposed Purchase Order for the materials. In that case, the CONTRACTOR shall review the Purchase Order for compliance with the construction documents, including, without limitation, the plans, specifications, and construction schedule. Within five (5) calendar days from the receipt of the proposed Purchase Order, the CONTRACTOR shall provide the COUNTY with written approval of the Purchase Order or shall provide written revisions to the Purchase Order, in order that the materials and the delivery will comply with the Construction Documents, including, without limitation, the plans, specifications and Construction Schedule.

E. The COUNTY will place the Order for the materials with the vendor.

F. The COUNTY will take title to those materials directly from the vendor and will bear the risk of loss or damage to the materials which are delivered by the vendor through the time that the materials are delivered to the location designated by the CONTRACTOR. After the materials are delivered to the location designated by the CONTRACTOR, the CONTRACTOR will have full responsibility for their storage, protection, risk-of-loss, and installation pursuant to the construction documents, including, without limitation, the plans, specifications, and construction schedule.

G. The vendor will invoice the COUNTY directly for the materials purchased from the vendor. The COUNTY shall pay the invoices for the materials directly, presenting its sales tax exemption certificate to each vendor at the time of payment.

With respect to the materials specifically designated by this section, the CONTRACTOR will be relieved only of its responsibilities to place the order for the subject materials, to pay for the materials and to insure the materials against loss through the date that they are delivered to the location designated by the CONTRACTOR. Otherwise, nothing in this Agreement will revise or modify the CONTRACTOR'S responsibilities set forth in this Agreement, including, without limitation, the responsibility to schedule the timely ordering and delivery of the materials purchased under this Agreement, the management of the materials once delivered or the incorporation of the materials into the Service, as provided in the construction documents, including, without limitation, the plans, specifications and construction schedule.

**THE PURPOSE OF THE SALES TAX RECOVERY PROGRAM IS TO ACHIEVE COST SAVINGS FOR THE COUNTY. THE COST OF ANY MATERIALS PURCHASED THROUGH THE SALES TAX RECOVERY PROGRAM WILL BE DEDUCTED FROM THE CONTRACT AMOUNT. ALL SAVINGS REALIZED BY THE SALES TAX RECOVERY PROGRAM WILL INURE TO THE BENEFIT OF THE COUNTY. IT IS THE CONTRACTOR'S RESPONSIBILITY TO ADJUST ANY SUBCONTRACTS ACCORDINGLY.**

The COUNTY and CONTRACTOR shall execute a written change order described in this Agreement and approved in accordance with the COUNTY'S policy and the Change Order will become a part of the contract documents as provided in this Agreement. The CONTRACTOR'S fee will be calculated on the basis that the CONTRACTOR, rather than the COUNTY, procured the materials. Therefore, for purpose of calculating the fee, the total of subcontractor and supplier costs will include payments made by the COUNTY under this program. The calculation of the fee in this manner will provide, among other things, specific supplemental consideration for the provisions of this Article.

**4.17 Compensation of Contractor's Subcontractors and Suppliers.** Upon receipt of payment from the COUNTY, the CONTRACTOR shall pay each of its subcontractors and suppliers out of the amount received by the CONTRACTOR on account of such subcontractor's or supplier's portion of the Service, the amount to which each entity is entitled, reflecting percentages retained from payments to the CONTRACTOR on account of such entity's portion of the Service. CONTRACTOR shall comply with the timeframes set forth in Section 218.735(6), Florida Statutes, for remitting payment to subcontractors. The COUNTY will have no obligation to pay, and will not be responsible for payments to, the CONTRACTOR'S subcontractors or suppliers. However, the COUNTY reserves the right, but has no duty, to make payment jointly to the CONTRACTOR and to any of its subcontractors or suppliers if the COUNTY becomes aware that the CONTRACTOR fails to pay or unreasonably withholds payment from one or more of those entities. Such joint check procedure, if employed by the COUNTY, will create no rights in favor of any person or entity beyond the right of the named payees to payment of the check and will not be deemed to commit the COUNTY to repeat the procedure in the future.

**4.18** Final Payment. Prior to being entitled to receive final payment, and as a condition precedent, the CONTRACTOR must achieve Final Completion of the Service and provide documents needed for final payment. CONTRACTOR shall submit the *Contractors Final Payment Affidavit*, attached hereto as part of **Composite Exhibit E**, as part of CONTRACTOR'S final payment request.

**ARTICLE 5. COUNTY RESPONSIBILITIES.**

**5.1** The COUNTY shall designate a COUNTY staff member to act as COUNTY'S Project Manager. It is agreed to by the parties that the COUNTY'S Project Manager will decide all questions, difficulties, or disputes, of whatever nature, which may arise relative to the interpretation of the plans, construction, prosecution and fulfillment of the Scope of Services, and as to the character, quality, amount and value of any work done, and materials furnished, under or by reason of this Agreement. The COUNTY'S Project Manager may appoint representatives as desired that will be authorized to inspect all work done and all materials furnished.

**5.2** The COUNTY shall pay in accordance with the provisions set forth in this Agreement.

**5.3** The COUNTY retains the right to inspect all work to verify compliance with the contract documents. Such inspection may extend to all or any part of the work and to the manufacture, preparation, or fabrication of the materials to be used.

**ARTICLE 6. FACILITIES PROVISIONS.**

**6.1** Intent of the Contract Documents.

**A.** For purposes of this Agreement, the term "contract documents" includes all bid documents, drawings, the Scope of Work, attachments to this Agreement, and provisions within this Agreement, along with any change orders or amendments to this Agreement.

**B.** It is the intent of the contract documents to describe a functionally complete Service which defines the Scope of Work. Any work, materials, or equipment that may reasonably be inferred from the contract documents as being required to produce the intended result must be supplied whether or not specifically called for. When words which have a well-known technical or trade meaning are used to describe work, material or equipment, such words must be interpreted in accordance with that meaning. Reference to standard specifications, manuals or codes of any technical society, organization or association or to the laws or regulations of any governmental authority having jurisdiction over the Service, whether such reference be specified or by implication, will mean the latest standard specification, manual, code, law or regulation in effect at the time the work performed, unless specifically stated otherwise in this Agreement.

**C.** The contract documents and all referenced standards cited in the contract documents are essential parts of the contract requirements. A requirement occurring in one is binding as though occurring in all.

**D.** Drawings and specifications are intended to agree and be mutually complete. Any item not contained within the drawings, but are contained in the specifications, or vice-versa, must be provided and executed as shown in either the drawing or specification at no extra costs to the COUNTY. Should anything not included in either the drawing or the specifications be necessary for the proper construction and operation of the Service as specified in this Agreement, or should any error or disagreement between the specifications and drawings exist or appear to exist, the CONTRACTOR may not derive any unjust benefit,

or use such disagreement counter to the best interests of the COUNTY. The CONTRACTOR shall immediately notify the COUNTY'S Project Manager of any discrepancy and await the Project Manager's direction before proceeding with the work in question.

**6.2** Errors and Omissions. The CONTRACTOR shall not take advantage of any apparent error or omission in the contract documents. If any error or omission appears in the contract documents, the CONTRACTOR shall immediately notify the COUNTY in writing of such errors or omissions. In the event the CONTRACTOR knows or should have known of any error or omission and failed to provide such notification, the CONTRACTOR will be deemed to have waived any claim for increased time or compensation the CONTRACTOR may have had and the CONTRACTOR will be responsible for the results and the costs of rectifying any such error or omission.

**6.3** Contractor Personnel.

**A.** The CONTRACTOR shall ensure that all personnel are competent, careful and reliable. All personnel must have sufficient skill and experience to perform their assigned task properly and satisfactorily and to operate any equipment involved and must make due and proper effort to execute the work in the manner prescribed in the contract documents.

**B.** When the COUNTY determines that any person is incompetent, unfaithful, intemperate, disorderly, or insubordinate, such person will be immediately discharged from the Service and will not again be employed on the Service without the written consent of the COUNTY. Should the CONTRACTOR fail to remove such person or persons, the COUNTY may withhold all payments which are or may become due or may suspend the work with approval of the COUNTY until such orders are complied with.

**C.** Superintendent. The CONTRACTOR shall at all times have at the Service site as its agent a competent superintendent capable and thoroughly experienced in the type of work being performed, who will receive instructions from the COUNTY. The superintendent shall supervise all trades, direct all Service activities, establish and maintain installation schedules, and provide the COUNTY'S Project Manager with progress reports as requested. The superintendent shall have full authority to execute the orders or directions of the COUNTY, and if applicable to promptly supply any materials, tools, equipment, labor and incidentals which may be required. Such superintendent must be furnished regardless of the amount of work sublet. The CONTRACTOR'S superintendent shall speak, write, and understand English and shall be on the job site during all working hours.

**D.** No alcoholic beverages or drugs are permitted on any COUNTY properties. Evidence of alcoholic beverages or drug use by an individual will result in immediate termination from the job site.

**E.** Dress Code & Identification. The CONTRACTOR shall maintain a dress code for their employees with a minimum of shirts, pants, and work shoes/boots, in decent condition, at all times while the work is being performed. Additionally, there may be times in which the COUNTY will require all workers on a particular individual Service to wear ID badges. The COUNTY shall supply the ID badges. If ID badges are necessary, the CONTRACTOR will ensure that all workers employed for that particular Service, whether employed by the CONTRACTOR or a subcontractor, are scheduled, prior to assignment, for an appointment during the COUNTY'S normal working hours with the COUNTY'S Project Manager, to process and receive ID badges. All new workers must be assigned an ID badge prior to starting work for that Service. The CONTRACTOR shall be aware that it may take up to one (1) week to receive ID badges after required information has been received and pictures have been taken.

F. Documentation. If required by the COUNTY for the Service, the CONTRACTOR shall provide the COUNTY'S Project Manager with all requested documentation for all personnel, subcontractors, and representatives of the CONTRACTOR that will be utilized for the Service. Documentation must be provided within five (5) working days of the request and must be submitted electronically in PDF format. This information must also be provided when new personnel, subcontractors, and representatives of the CONTRACTOR are hired at any time during the contract period for the Service. The information supplied will be used to run background checks and to provide identification badging, proximity cards, and keys. All documentation required below must be supplied in one (1) PDF attachment that must be titled with the company's name, the person's name, and the person's birthdate. Example: *ACME Plumbing - John H. Smith - 10/10/96*. The documentation must include the following:

1. Full name.
2. Address.
3. Email address.
4. Telephone number.
5. Copy valid of driver's license, State of Florida identification card, passport, and/or work visa.
6. A current, clear, color photo (head shot) taken with a plain background.
7. Building names and addresses of the facilities where the individual will be working.
8. Any additional information that may be requested by the Lake County Sheriff's Office.

G. Criminal Justice Information Services (CJIS). When advised by the COUNTY'S Project Manager, the CONTRACTOR'S personnel, subcontractors, and representatives will be required to complete an online training class that includes testing in order to have access to some secure areas of COUNTY facilities. Finger printing may also be required and will be performed by the Lake County Sheriff's Office at no expense to the CONTRACTOR.

H. Background Checks. The services provided under this agreement will be conducted in a public park, in proximity to minors therefore all CONTRACTOR and subcontractor personnel must successfully complete a Certified Background Check prior to accessing the site. CONTRACTOR shall provide Certified Background Checks at no additional cost to COUNTY. COUNTY retains the right to request and review any associated records with or without cause, and to require replacement of any CONTRACTOR employee or subcontractor employees found in violation of this requirement. CONTRACTOR shall indemnify COUNTY in full for any adverse actions of any such personnel in this regard.

I. Identification Badging / Proximity Cards / Keys

1. The CONTRACTOR'S personnel, subcontractors, and representatives that are approved to work in restricted areas will receive an identification badge which will also act as a proximity card.

2. All approved personnel, subcontractors, and representatives of the CONTRACTOR will be issued identification badges and will be required to wear them at all times while on the COUNTY'S property. At no time will personnel, subcontractors, and representatives of the CONTRACTOR be allowed to work on the COUNTY'S property prior to being given approval by the Facilities Maintenance Division Manager and the assignment of a CONTRACTOR identification badge.

3. For facilities that do not have proximity card readers, keys will be issued to approved personnel, subcontractors, and representatives of the CONTRACTOR.

4. The Facilities Maintenance Division Manager will notify the CONTRACTOR by email that identification badges, proximity cards, and keys are ready for pickup, and will have the CONTRACTOR complete release forms and then distribute them to the CONTRACTOR for disbursement to their personnel, subcontractors, and representatives. The COUNTY'S Project Manager must be copied on the email.

**G. Lost/Stolen/Damaged Identification Badges / Proximity Cards / Keys**

1. In the event that an identification badge, proximity card or key is lost, stolen or damaged, the CONTRACTOR shall immediately email the Facilities Maintenance Division Manager and the COUNTY'S Project Manager.

2. Personnel, subcontractors, and representatives of the CONTRACTOR must be temporarily substituted by the CONTRACTOR with a suitable replacement until the CONTRACTOR has obtained a new identification badge/proximity card.

3. The CONTRACTOR will be assessed a \$25.00 fee for each lost, stolen, or damaged card and key in order to reimburse costs incurred by the COUNTY. All fees due will be deducted from the CONTRACTOR'S next invoice.

**H. Reports.** The CONTRACTOR shall provide an initial report within thirty (30) business days of the start date and then annually for all employees currently being utilized for the Service. All additions and changes must be highlighted in yellow. The COUNTY'S Project Manager will provide a standardized Excel form at contract initiation that will be used. Reports must be provided for the duration of the Service. Reports must be delivered electronically in PDF format to the Lake County Sheriff's Office Representative, the Facilities Maintenance Division Manager, and the COUNTY'S Project Manager. Reports must include the following information:

1. Individual's name, birthdate, and driver's license number.
2. Identification badge/proximity card number.
3. All facilities where the employee works.
4. All facilities accessible by proximity card or key.
5. The date the identification badge/proximity card was issued.
6. Dates of subsequently issued identification badges/proximity cards due to loss, theft, or damage.
7. The date that the individual left employment of the CONTRACTOR and the identification badge/proximity card was returned.

**I. Worker Dismissal / Leave Reporting**

1. The CONTRACTOR shall immediately email the Facilities Maintenance Division Manager and the COUNTY'S Project Manager upon the dismissal or permanent leave of any personnel, subcontractors, and representatives of the CONTRACTOR that are utilized for projects or services for the COUNTY.

2. The CONTRACTOR shall contact the Facilities Maintenance Division Manager to arrange to drop off identification badges, proximity cards, and keys of a dismissed workers within three (3) working days of dismissal or leave.

J. Service Completion

1. At the completion of the Service, the CONTRACTOR shall, within three (3) business days, arrange to meet with the Facilities Maintenance Division Manager to return all identification badges, proximity cards, and keys.
2. The CONTRACTOR will be assessed a \$25.00 fee for each missing identification badge, proximity card, and key in order to reimburse costs incurred by the COUNTY. All fees due will be deducted from the CONTRACTOR'S final invoice.

6.4 Subcontractors.

A. The CONTRACTOR will be fully responsible to the COUNTY for the acts and omissions of the CONTRACTOR'S subcontractors and of persons either directly or indirectly employed by them.

C. All subcontractors, for as long as the subcontractor is working on the job site, must have at least one supervisor/foreman on the job site that speaks and understands English.

D. The CONTRACTOR shall cause its subcontractors and suppliers to comply with the Service schedule and applicable sub-schedules.

E. The CONTRACTOR shall include with the final invoice a completed CONTRACTOR'S FINAL PAYMENT AFFIDAVIT, a copy of which is attached and incorporated by reference as **Exhibit E**. The invoice will not be processed without the form.

F. Subcontracting without the prior consent of COUNTY may result in termination of the Agreement for default.

6.5 Completion of the Scope of Services. The CONTRACTOR shall give the work the attention necessary to assure the scheduled progress and shall cooperate fully with the COUNTY and with other contractors on the job site. All work must be done in accordance with the contract documents. When not specifically identified in the technical specifications, such materials and equipment must be of a suitable type and grade for the purpose. All material, workmanship, and equipment will be subject to the inspection and approval of the COUNTY.

6.6 Emergencies. Dependent on COUNTY need, the CONTRACTOR must have a responsible person available at, or reasonably near, the Service on a twenty-four (24) hour basis, seven (7) days a week, who may be contacted in emergencies and in cases where immediate action must be taken to maintain traffic or to handle any other problem that might arise. The CONTRACTOR'S responsible person for supervision of emergencies must speak and understand, both verbally and in writing, the English language. The CONTRACTOR shall submit to the COUNTY'S Project Manager, the phone numbers and names of personnel designated to be contacted in cases of emergencies. Included in this list must be a twenty-four (24) hour contact phone number for all subcontractors, if any, performing work under this Agreement. This list must contain the name of their supervisors responsible for work pertaining to this Agreement.

In the event of an emergency affecting the safety or protection of persons, or the work or property at a Service site or adjacent to a Service site, the CONTRACTOR, without special instruction or authorization from the COUNTY, is obligated to act to prevent threatened damage, injury, or loss. The CONTRACTOR shall contact the COUNTY as soon as possible by telephone and with written notice as soon as feasible



after the emergency, but no later than twenty-four (24) hours after the occurrence of the emergency, if the CONTRACTOR believes that any significant changes in the work or variations from the contract documents has occurred. If the COUNTY determines that a change in the contract documents is required because of the action taken in response to an emergency, a change order request will be issued to document the consequences of the changes or variations. If the CONTRACTOR fails to provide written notice within the twenty-four (24) hour limitation noted above, the CONTRACTOR will be deemed to have waived any right it otherwise may have had to seek an adjustment to the contract amount or an extension to the contract time.

**6.7**    Safety.

**A.**    The CONTRACTOR shall initiate, maintain, and supervise all safety precautions and programs in connection with the work, and shall comply with all requirements of the Occupational Safety and Health Administration (OSHA) and any other industry, Federal, State or local government standards, including the National Institute of Occupational Safety Hazards (NIOSH), and the National Fire Protection Association (NFPA). The CONTRACTOR shall take all necessary precautions for the safety of, and shall provide the necessary protection to prevent damage, injury or loss to, persons or property. The CONTRACTOR shall be aware that while working for the COUNTY, representatives from agencies such as OSHA are invitees and need not have warrants or permission to enter the work site. Any fines levied by the above-mentioned authorities for failure to comply with these requirements will be borne solely by the CONTRACTOR.

**B.**    The CONTRACTOR certifies that all material, equipment, etc. to be used in an individual Service meets all Occupational Safety and Health Administration (OSHA) requirements. The CONTRACTOR further certifies that if any of the material, equipment, etc. is found to be deficient in any OSHA requirement in effect on the date of delivery, all costs necessary to bring the material, equipment, etc. into compliance with these requirements will be borne by the CONTRACTOR. All standard equipment, work operations, safety equipment, personal protective equipment, and lighting required or mandated by State, Federal, OSHA, or Americans with Disabilities Act (ADA) regulations must be provided and used by the CONTRACTOR and its employees.

**C.**    All safety devices installed by the manufacturer on equipment utilized by the CONTRACTOR on the jobsite must be in place and in proper working order at all times. If the COUNTY determines that equipment is deficient in safety devices, the CONTRACTOR will be notified immediately. The CONTRACTOR shall immediately repair or remove the equipment from service until the deficiency is corrected to the satisfaction of the COUNTY.

**D.**    The COUNTY may periodically monitor the work site for safety. Should there be safety or health violations, the COUNTY will have the authority, but not the duty, to require the CONTRACTOR to correct the violation in an expeditious manner. If there is any situation that is deemed unsafe by the COUNTY, the Service will be shut down immediately upon notice and will not resume work until the unsafe condition has been remedied. CONTRACTOR shall receive no additional compensation, no extension of time, and shall not be entitled to reimbursement of any demobilization costs, remobilization costs, or other out-of-pocket expenses incurred as a result of such work stoppage. If the violation is not corrected within a reasonable time, COUNTY may in its sole discretion declare CONTRACTOR to be in default of this Agreement.

**E.**    Should the work site be in a hazardous area, the COUNTY shall take reasonable actions to furnish the CONTRACTOR with information concerning hazards such as the types or the identification of known toxic material, machine hazards, Safety Data Sheets, or any other information that would assist the

CONTRACTOR in the planning of a safe work site. The CONTRACTOR retains the ultimate responsibility to ensure all work is performed in a manner consistent with all applicable safety standards and directives. **CONTRACTOR acknowledges that the location of the work is on natural lands and adjacent to and on a natural water body and wetland areas with limited access from land. CONTRACTOR is solely responsible for ensuring safety related to any additional or unique hazards due to the nature and location of the work.**

F. The CONTRACTOR shall erect and maintain, as required by existing conditions and contract performance, safeguards for safety and protection such as barricades, danger signs, a construction fence, and other warnings against hazardous conditions.

G. The CONTRACTOR shall remove all surplus material and debris from the Service site at the end of each workday. All costs associated with clean-up and debris removal must be included in the lump sum price stated elsewhere in this Agreement. The CONTRACTOR shall leave the site clean and neat. All work must be cleaned up prior to the next day of business. At no time may the specified work interfere with the regular operating hours of Lake County.

H. CONTRACTOR must have sufficient and Service appropriate supplies on-site for clean-up. At no time may the CONTRACTOR use COUNTY cleaning supplies or equipment. Upon final completion, the CONTRACTOR shall thoroughly clean-up all areas where work has been involved as mutually agreed with the COUNTY'S Project Manager. **If at any time the CONTRACTOR fails to clean up the work area to acceptable levels, the COUNTY may retain outside cleaning services and the actual costs for this service will be deducted from the CONTRACTOR'S final payment with the minimum cost of \$50.00 to offset the COUNTY'S time for securing services to properly clean and inspect the site.**

I. The CONTRACTOR shall confine all equipment, materials and operations to the Service site and areas identified in the agreement documents. The CONTRACTOR shall assume all responsibility for any damage to any such area resulting from the performance of the work.

J. Hazardous Materials. CONTRACTOR is responsible for notifying the COUNTY of any hazardous materials used on the work site and providing the COUNTY a copy of the Safety Data Sheets (SDS). Any spillage of hazardous chemicals or wastes by the CONTRACTOR will be reported immediately to the COUNTY and cleaned up in accordance with all State and Federal Regulations. The cost of cleanup of any spillage of hazardous chemicals or wastes caused by CONTRACTOR will be the sole responsibility of CONTRACTOR and the COUNTY will share no responsibility of these costs. A copy of the complete report showing compliance with local, state, and federal agencies will be given to the COUNTY. If any hazardous chemicals or conditions are discovered during the normal operation, it is the responsibility of CONTRACTOR to immediately contact the COUNTY with a description and location of the condition. The SDS must meet the requirements of 29 CFR 1910.1200(g), and include the following information:

- Section 1: Identification;
- Section 2: Hazard(s) identification;
- Section 3: Composition/information on ingredients;
- Section 4: First-aid measures;
- Section 5: Fire-fighting measures;
- Section 6: Accidental release measures;
- Section 7: Handling and storage;
- Section 8: Exposure controls / personal protection;
- Section 9: Physical and chemical properties;

- Section 10: Stability and reactivity;
- Section 11: Toxicological information;
- Section 12: Ecological information;
- Section 13: Disposal considerations;
- Section 14: Transport information;
- Section 15: Regulatory information; and
- Section 16: Other information, including date of preparation or last revision.

The CONTRACTOR shall designate a competent person of its organization whose duty will be the prevention of accidents. This person must be literate and able to communicate fully in the English language because of the necessity to read job instructions and signs, as well as the need for conversing with management personnel. This person will be the CONTRACTOR'S superintendent unless otherwise designated in writing to the COUNTY'S Project Manager. All communications to the superintendent will be as binding as if given to the CONTRACTOR.

**K. Tobacco Products.** Tobacco use, including both smoke and smokeless tobacco, is prohibited on COUNTY owned property.

**6.8 Underground Utilities.** Any required digging or subsurface work will be done in accordance with Chapter 556, Florida Statutes. It will be the responsibility of CONTRACTOR to have all underground utilities located before any work begins (Sunshine State One Call 1-800-432-4770). The repairs of any damaged underground utilities because of the work being performed by CONTRACTOR will be the responsibility of CONTRACTOR. The proper utility company will be contacted immediately to expedite the repairs if damage has occurred. CONTRACTOR will notify the COUNTY and provide a written explanation of the incident within two days of the damage to any underground utilities.

**6.9 Maintenance of Traffic.**

**A.** In the event that any of the work is conducted within any public right of way, the CONTRACTOR shall provide proper Maintenance of Traffic (MOT). Unless otherwise specified, the standard specifications to be used for the Service will be the strictest and latest edition as promulgated by the Florida Department of Transportation (FDOT) or the Federal Highway Administration (FHWA).

**B.** Maintenance of traffic will be the responsibility of the CONTRACTOR, is part of the CONTRACTOR'S proposal price, and must conform to FDOT's most current editions and supplements of Standard Specifications for Road and Bridge Construction, Roadway and Traffic Design Standards, Manual or Uniform Minimum Standards for Design, Construction and Maintenance for Streets and Highways, or the Federal Highway Administration (FHWA) Manual on Uniform Traffic Control Devices (MUTCD), as applicable. These documents can be ordered from FDOT, Maps and Publications Department, 605 Suwannee Street, Tallahassee, Florida, 32399-0450, or by going to the FDOT website at: <https://www.fdot.gov/publications/publications.shtm>.

**C.** All costs associated with MOT must be included in the CONTRACTOR'S proposal price. No separate line items for MOT will be included in the cost estimate. If the CONTRACTOR does not comply with all of the FDOT and the FHWA standards (i.e., signs, qualified flaggers, and barricades), the COUNTY reserves the right to direct the CONTRACTOR to cease operation until deficiencies are corrected. In addition, no road closures will be allowed except in the case of emergencies.

D. If the CONTRACTOR feels that assistance from an off-duty police officer is needed, it will be the responsibility of the CONTRACTOR, at the CONTRACTOR'S sole cost and expense, to hire and pay for this service.

E. All lane closures must have the prior approval of the COUNTY.

F. These requirements are to be considered a minimum and the CONTRACTOR'S compliance will in no way relieve the CONTRACTOR of final responsibility for providing adequate traffic control devices for the protection of the public and the CONTRACTOR'S employees throughout the work area.

G. The use of public roads and streets by the CONTRACTOR must provide minimal inconvenience to the public and traffic. Furthermore, if the CONTRACTOR is utilizing a road by driving slow moving equipment, the operator must allow no more than three (3) vehicles to be backed up behind them at any time before pulling to the side to let traffic pass.

#### **6.10 General Inspection Requirements.**

A. Due to the nature of this Agreement, the COUNTY will, at the time of establishment of need, require the CONTRACTOR to become fully informed as to the nature and extent of the work required and its relation to any other work in the area, including possible interference from other site activities. Arrangement for the CONTRACTOR'S inspection of facilities or sites and activity schedules may be secured from the user COUNTY department. Failure to visually inspect the facilities or sites may be cause for disqualification of the CONTRACTOR on that individual Service.

B. The CONTRACTOR shall furnish the COUNTY with every reasonable accommodation for ascertaining whether the work performed and materials used are in accordance with the requirements and intent of the contract documents. If the COUNTY so requests, the CONTRACTOR shall, at any time before final acceptance of the work, remove or uncover such portions of the finished work as may be directed. After examination, the CONTRACTOR shall restore the uncovered portions of the work to the standard required by the specifications. Should the work so exposed or examined prove unacceptable in the opinion of the COUNTY, the uncovering or removal, and the replacing of the covering or making good of the parts removed, will be at the CONTRACTOR'S expense. However, should the work thus exposed or examined prove acceptable in the opinion of the COUNTY, the uncovering or removing and the replacing or the covering or making good of the parts removed, will be paid for as unforeseen work.

C. If the COUNTY should, at any point before, during, or after, completion of construction activities, fail to reject defective work or materials, whether from lack of discovery of such defect or for any other reason, such initial failure to reject will in no way prevent the COUNTY'S later rejection when such defect is discovered, nor obligate the COUNTY to final acceptance or payment, and the CONTRACTOR will make no claim for losses suffered due to any necessary removals or repairs of such defects.

D. If, during or prior to construction operations, the COUNTY rejects any portion of the work on the grounds that the work or materials are defective, the COUNTY shall give the CONTRACTOR notice of the defect, which notice may be confirmed in writing. The CONTRACTOR will then have seven (7) calendar days from the date the notice is given to correct the defective condition. If the CONTRACTOR fails to correct the deficiency within the seven (7) calendar days after receipt of the notice, the COUNTY may take any action necessary, including correcting the deficient work utilizing another CONTRACTOR, returning any non-compliant goods to the CONTRACTOR at the CONTRACTOR'S expense or terminating the contract. The CONTRACTOR may not assess any additional charges for any conforming action taken

by the COUNTY. The COUNTY will not be responsible to pay for any product or service that does not conform to the contract specifications.

E. Should the CONTRACTOR fail to remove and renew any defective materials used or work performed, or to make any necessary corrections in an acceptable manner and in accordance with the contract requirements, within the time indicated in writing, the COUNTY will have the authority to cause the unacceptable or defective materials or work to be corrected as necessary at the CONTRACTOR'S expense. Any expense incurred by the COUNTY, whether direct, indirect or consequential, in making these repairs, removals, or renewals will be paid for out of any monies due or which may become due to the CONTRACTOR. A change order will be issued, incorporating the necessary revisions to the contract documents, including an appropriate decrease to the contract amount. Such costs will include, but not be limited to, costs of repair and replacement of work destroyed or damaged by correction, removal or replacement of the CONTRACTOR'S defective work and additional compensation due the COUNTY. The CONTRACTOR will not be allowed an extension of the contract time because of any delay in performance of the Service attributable to the exercise by the COUNTY of the COUNTY'S rights and remedies under this Agreement. If the CONTRACTOR fails to honor the change order, the COUNTY may terminate this Agreement for default.

F. All work performed and all materials furnished must be in conformity with the tolerances indicated in the specifications. In the event the COUNTY'S Project Manager finds the materials or the finished product in which the materials are used and in conformity with the specifications, the COUNTY'S Project Manager will then make a determination if the work will be accepted and remain in place. In this event, the COUNTY'S Project Manager will document the basis of acceptance by a Change Order that will provide for an appropriate deduction as needed in the contract price for such work or materials as the COUNTY'S Project Manager deems necessary to conform to the determination based on the COUNTY'S Project Manager's professional judgment.

G. When the United States Government or the State of Florida is to pay a portion of the cost of construction, the work will be subject to such inspection by Federal or State representatives as deemed necessary, but such inspections will in no case make the United States Government or the State of Florida a party to this contract.

#### **6.11 Service Materials and Storage.**

A. Unless otherwise specified within the contract documents, all materials to be used to complete the Service, except where recycled content is specifically requested, must be new, unused, of recent manufacture, and suitable for its intended purpose. All goods must be assembled, fully serviced and ready for operation when delivered. In the event any of the materials supplied by the CONTRACTOR are found to be defective or do not conform to specifications: (1) the materials may be returned to the CONTRACTOR at the CONTRACTOR'S expense and this Agreement may be terminated or (2) the COUNTY may require the CONTRACTOR to replace the materials at the CONTRACTOR'S expense.

B. Materials must be placed to permit easy access for proper inspection and identification of each shipment. Any material which has deteriorated, become damaged, or is otherwise unfit for use, as determined by the COUNTY, must not be used for the Service, and must be removed from the site by the CONTRACTOR at the CONTRACTOR'S expense. Until incorporated into the work, materials will be the sole responsibility of the CONTRACTOR and the CONTRACTOR will not be paid for such materials until incorporated into the work. If any chemicals, materials or products containing toxic substances are to be used at any time, the CONTRACTOR shall furnish a Material Safety Data Sheet to the COUNTY prior to commencing such use.

C. When not specifically identified in the technical specifications, materials and equipment must be of a suitable type and grade for the purpose which they are used.

D. All unusable materials and debris must be removed from the premises by the CONTRACTOR at the end of each workday and disposed of in an appropriate manner.

#### **6.12** Time for Completion and Extensions.

A. A written Notice to Proceed is required for the CONTRACTOR to schedule or begin work. Purchase Orders will be issued for Services to the CONTRACTOR. Issuance of a Purchase Order is not a directive to begin work unless otherwise specified. Email notice is acceptable.

B. The CONTRACTOR shall diligently pursue the completion of the work and coordinate the work being done on the Service by its subcontractors and material suppliers, as well as coordinate the CONTRACTOR'S work with the work of other contractors so that the CONTRACTOR'S work or the work of others will not be delayed or impaired. The CONTRACTOR will be solely responsible for all construction means, methods, techniques, sequences, and procedures, as well as coordination of all portions of the work under the contract documents. The time for completion requirements are contained in Article 3.3 above.

C. Should the CONTRACTOR be obstructed or delayed in the completion of the work as a result of unforeseeable causes beyond the control of the CONTRACTOR, and not due to the CONTRACTOR'S fault or neglect, the CONTRACTOR shall notify the COUNTY in writing within twenty-four (24) hours after the commencement of such delay, stating the cause or causes of the delay, or be deemed to have waived any right which the CONTRACTOR may have had to request a time extension.

D. If the CONTRACTOR complies with the twenty-four (24) hour notice requirement, the COUNTY will ascertain the facts and the extent of the delay being claimed and recommend an extension to the contract time when, in the COUNTY'S sole judgment, the findings of fact justify such an extension. The CONTRACTOR shall cooperate with the COUNTY'S investigation of the delays by providing any schedules, correspondence or other data that may be required to complete the findings of fact. Extensions to the contract time may be granted only for those delays which impact the CONTRACTOR'S construction schedule. Extensions of contract time, if approved by the COUNTY, must be authorized by written change order.

#### **6.13** Changes in the Scope of Services.

A. The COUNTY may at any time, by written change order, in accordance with the COUNTY'S Purchasing Policy and Procedures, increase or decrease the scope of the work. For changes in work requested by the CONTRACTOR, the CONTRACTOR must prepare and submit change order requests for the COUNTY'S approval. Each change order will include time and monetary impacts of the change, whether the change order is considered alone or with all other changes during the course of the Service. Both the COUNTY and the CONTRACTOR must execute the change order for the order to become effective.

B. The value of such extra work or change will be determined by the contract unit values, if applicable unit values are set forth in this Agreement. The amount of the change will be computed from such values and added to or deducted from the contract price.

C. If the COUNTY and the CONTRACTOR are unable to agree on the change order for a requested change, the CONTRACTOR shall, nevertheless, promptly perform the change as directed in writing by the COUNTY. If the CONTRACTOR disagrees with the COUNTY'S adjustment determination, the CONTRACTOR must make a claim pursuant to the Claims and Disputes section in this Agreement, or else be deemed to have waived any claim on this matter the CONTRACTOR might have otherwise had.

D. For work not contemplated by the original Agreement where the Project Manager determines the CONTRACTOR is best suited to complete the work, CONTRACTOR may complete the work under a time-and-materials agreement, as provided herein. CONTRACTOR'S quote to complete the additional work will be limited to (i) the CONTRACTOR'S reasonable direct material costs and reasonable actual equipment costs as a result of the change and (ii) direct labor hours charged at fixed hourly rates that reflect wages, general and administrative expenses, and profit. In such case, the CONTRACTOR will keep and present to the COUNTY an itemized accounting together with appropriate supporting data for the total cost incurred. In the event such changed work is performed by a subcontractor, additional work will be limited to (i) the subcontractor's reasonable direct material costs and reasonable actual equipment costs as a result of the change and (ii) direct labor hours charged at fixed hourly rates that reflect wages, general and administrative expenses, and profit. CONTRACTOR may charge appropriate reasonable direct hourly costs related to overseeing and subcontracting the work. All compensation due the CONTRACTOR and any subcontractor or sub-subcontractor for field and home office overhead is included in the markups listed above. Payment to CONTRACTOR will be limited to the amount quoted by the CONTRACTOR for the additional work, which the CONTRACTOR exceeds at its own risk.

E. The COUNTY will not be liable to the CONTRACTOR for any increased compensation in the absence of a written change order executed in accordance with the COUNTY'S policy. The payment authorized by such a change order will represent full and complete compensation to the CONTRACTOR for labor, materials, incidental expenses, overhead, profit, impact costs and time associated with the work authorized by such change order.

F. Execution by the CONTRACTOR of a properly authorized change order will be considered a waiver of all claims or requests for additional time or compensation for any activities prior to the time of execution related to items included in the change order.

G. Upon receipt of an approved change order, changes in the Scope of Services must be promptly performed. All changes in work must be performed under the terms and conditions of this Agreement.

H. Change orders will not be issued for incidental items or tasks that should have been reasonably construed to be part of the project by the CONTRACTOR.

#### **6.14 Claims and Disputes.**

A. Claims by the CONTRACTOR must be made in writing to the COUNTY within two (2) business days, unless another provision of this Agreement sets forth a different time frame, after the commencement of the event giving rise to such claim or the CONTRACTOR will be deemed to have waived the claim. All claims will be priced in accordance with the section in this document entitled "Changes in the Scope of Services."

B. The CONTRACTOR shall proceed diligently with its performance as directed by the COUNTY, regardless of any pending claim, action, suit, or administrative proceeding, unless otherwise

agreed to by the COUNTY in writing. The COUNTY shall continue to make payments on the undisputed portion of the contract in accordance with the contract documents during the pendency of any claim.

C. Claims by the CONTRACTOR will be resolved in the following manner: (1) Upon receiving the claim and supporting data, the COUNTY will within fifteen (15) calendar days respond to the claim in writing stating that the claim is either approved or denied. If denied, the COUNTY will specify the grounds for denial. The CONTRACTOR will then have fifteen (15) calendar days in which to provide additional supporting documentation, or to notify the COUNTY that the original claim stands as is. (2) If the claim is not resolved, the COUNTY may, at its option, choose to submit the matter to mediation. A mediator will be mutually selected by the parties and each party will pay one-half (1/2) the expense of mediation. If the COUNTY declines to mediate the dispute, the CONTRACTOR may bring an action in a court of competent jurisdiction in and for Lake County, Florida.

D. Claims by the COUNTY against the CONTRACTOR must be made in writing to the CONTRACTOR as soon as the event leading to the claim is discovered by the COUNTY. Written supporting data will be submitted to the CONTRACTOR. All claims will be priced in accordance with the provisions of the section in this document entitled "Changes in the Scope of Services." The CONTRACTOR shall respond in writing within fifteen (15) calendar days of receipt of the claim. If the claim cannot be resolved, the COUNTY may submit the matter to mediation as set forth in I above.

E. Arbitration will not be considered as a means of dispute resolution.

F. **NO CLAIM FOR DAMAGES OR ANY CLAIM OTHER THAN FOR AN EXTENSION OF TIME MAY BE MADE OR ASSERTED AGAINST THE COUNTY BY REASON OF ANY DELAYS.** No interruption, interference, inefficiency, suspension or delay in the commencement or progress of the work will relieve the CONTRACTOR of its duty to perform or give rise to any right to damages or additional compensation from the COUNTY. The CONTRACTOR expressly acknowledges and agrees that the CONTRACTOR will receive no damages for delay. However, this provision will not preclude recovery or damages by the CONTRACTOR for hindrances or delays due solely to fraud, bad faith, or active interference on the part of the COUNTY. Otherwise, the CONTRACTOR will be entitled to extensions of the contract time as the sole and exclusive remedy for such resulting delay, in accordance with and to the extent specifically provided above.

#### **6.15 Acceptance of the Work and Final Payment.**

A. The work delivered and services rendered under this Agreement will remain the property of the CONTRACTOR and will not be deemed complete until a physical inspection and actual usage of the Service is accepted by the COUNTY and will be in compliance with the terms of this Agreement, fully in accord with the specifications and of the highest quality. Any goods or services purchased under this Agreement may be tested/inspected for compliance with the specifications listed.

B. Maintenance of Work. The CONTRACTOR shall maintain all work in as-new condition until the final inspection is completed and the work is accepted by the COUNTY. All insurance must be maintained until final acceptance by the COUNTY.

C. Final Invoice. When the work provided for under this Agreement has been completely performed by the CONTRACTOR a final invoice will be prepared by the CONTRACTOR. The amount of this invoice, less any sums that may have been deducted or retained under the provisions of this Agreement, will be paid to the CONTRACTOR in accordance with Article 4 of this Agreement, and after the CONTRACTOR has agreed in writing to accept the balance due, as determined by the COUNTY, as



full settlement of the account under the contract and of all claims in connection with the invoice. Occupancy by the COUNTY alone does not constitute final acceptance.

**D. Final Inspection.** When all materials have been furnished, all work has been performed, and the construction contemplated by this Agreement has reached substantial completion, CONTRACTOR shall request a final inspection by the COUNTY. The COUNTY, or the COUNTY'S representative, shall make the final inspection within five (5) business days of receipt of notification from the CONTRACTOR that the Service is ready. The COUNTY shall, pursuant to Section 218.735(7), Florida Statutes, prepare and deliver to the CONTRACTOR a single list of items required to render the Service complete, satisfactory, and acceptable within thirty (30) calendar days after being notified by CONTRACTOR of the project, or project phase if the project is multi-phased, reaching substantial completion. The single list will be delivered by the COUNTY to the CONTRACTOR within five (5) days after the list of items has been developed and reviewed.

The failure by the COUNTY to include any corrective work or pending items on the list does not alter CONTRACTOR'S responsibility for completing the Service pursuant to this Agreement. All items that require correction under the contract and that are identified after the preparation and delivery of the list remain the obligation of CONTRACTOR as defined by this Agreement. The CONTRACTOR shall correct all deficiencies before final acceptance and payment of retainage is made.

**E. Final Acceptance.** Final completion must be within thirty (30) days after delivery of the list of items in paragraph D of this section. If the COUNTY fails to provide the list as provided for in paragraph D of this section, the time for completion will be extended by the number of days the COUNTY exceeded the delivery date. COUNTY will re-inspect to verify completion of the list of items provided to CONTRACTOR for final acceptance. An eighty-dollar (\$80.00) re-inspection fee will be applied for the third inspection and any required re-inspection. The COUNTY may exclude the CONTRACTOR from those portions of the work designated as complete after the inspection; provided, however, that the CONTRACTOR will have reasonable access for the time allotted by the COUNTY to complete or correct items on the punch list.

**F. Release of Retained Funds.** As set forth in Section 218.735, Florida Statutes, upon completion and acceptance by the COUNTY of all items on the list of items provided for in paragraph D of this section, CONTRACTOR may submit a payment request for all remaining retainage withheld for the project, or phase of project, as applicable. If a good faith dispute exists as to whether one or more of the items identified in the list have been completed pursuant to the contract, COUNTY may continue to withhold up to 150% of the total costs to complete such items. CONTRACTOR shall submit CONTRACTOR'S Final Payment Affidavit with the request for payment.

**G. Waiver of Claims.** The CONTRACTOR'S acceptance of final payment will constitute a full waiver of any and all claims by the CONTRACTOR against the COUNTY arising out of this Agreement or otherwise related to the Service, except those previously made in writing and identified by the CONTRACTOR as unsettled at the time the final estimate is prepared. Neither the acceptance of the work nor payment by the COUNTY will be deemed a waiver of the COUNTY'S rights to enforce any continuing obligations of the CONTRACTOR or to the recovery of damages for defective work not discovered by the COUNTY at the time of final inspection.

**H. Termination of Contractor's Responsibilities.** This Agreement will be considered complete when all work has been completed and accepted by the COUNTY and all warranty periods have expired. The CONTRACTOR will then be released from further obligation except as set forth in this Agreement.

I. Recovery Rights Subsequent to Final Payment. The COUNTY reserves the right, should an error be discovered in the invoice, or should proof of defective work or materials used by or on the part of the CONTRACTOR be discovered after the final payment has been made, to claim and recover from the CONTRACTOR by process of law, such sums as may be sufficient to correct the error or make good the defects in the work and materials, including any fees or costs associated with the additional services of the COUNTY.

**6.16 Warranties.**

A. All warranties will begin on the date of the COUNTY'S acceptance and will last for a period of twelve (12) months unless otherwise specified in the Scope of Services, plans, or specifications. The CONTRACTOR shall obtain and assign to the COUNTY all express warranties given to the CONTRACTOR or any subcontractors by any material suppliers, equipment, or fixtures to be incorporated into the Service.

B. The CONTRACTOR warrants to the COUNTY that any materials and equipment furnished under the contract documents will be new unless otherwise specified, and that all work will be of good quality, free from defects and in conformance with the contract documents. The CONTRACTOR further warrants to the COUNTY that all materials and equipment furnished under the contract documents will be applied, installed, connected, erected, used, cleaned, and conditioned in accordance with the instructions of the applicable manufacturers, fabricators, suppliers, or processors except as otherwise provided for the contract documents. This warranty requirement will remain in force for the full period identified above, regardless of whether the CONTRACTOR is still under contract at the time of the defect. These warranties are in addition to those implied warranties to which the COUNTY is entitled as a matter of law.

C. If sod is used as part of an individual Service, it will be warranted to be free of noxious and invasive weeds, disease, and insects. If pests or noxious weeds manifest themselves within sixty (60) days of placement of the sod, CONTRACTOR will treat the affected areas. The process for treating these areas will be approved by the COUNTY. If the sod does not meet any of the required specifications, CONTRACTOR will be responsible to replace it at no expense to the COUNTY. It will be the responsibility of CONTRACTOR to ensure the sod is sufficiently established as described as specified in the Scope of Services, plans, or specifications. This will include watering the sod on a regular basis as needed to keep it alive until established. Established will be considered as being sufficiently rooted, as determined by the COUNTY Project Manager, into the surface that it was installed. If the sod dies or does not become established CONTRACTOR will be responsible for the replacement at no cost to the COUNTY.

D. CONTRACTOR will be responsible for promptly correcting all apparent and latent deficiencies or defects in work, regardless of the project completion status, at no cost to the COUNTY, within five (5) calendar days after the COUNTY notifies CONTRACTOR of such deficiency in writing. If CONTRACTOR fails to honor the warranty or fails to correct or replace the defective work or items within the period specified, the COUNTY may, at its discretion, notify CONTRACTOR in writing that CONTRACTOR may be debarred as a COUNTY vendor, and become subject to contractual default if the corrections or replacements are not completed to the satisfaction of the COUNTY within five (5) calendar days of receipt of the notice. If CONTRACTOR fails to satisfy the warranty within the period specified in the notice, the COUNTY may (a) place CONTRACTOR in default of its agreement and (b) procure the products or services from another source and charge CONTRACTOR for any additional costs that are incurred by the COUNTY for this work or items, either through a credit memorandum or through invoicing.

**6.17 Liquidated Damages.**

**A.** Unless otherwise agreed to, weather events are specifically excluded as excused cause for delay under this Agreement and no additional days will be given for rain days. If the deficiencies have been noted and the remedies have not been completed within the contracted time, the COUNTY may send out a notification notifying the CONTRACTOR of an assessment of Liquidated Damages that can be applied for any day over the time allowed under this Agreement.

**B.** The COUNTY and the CONTRACTOR recognize that, since time is of the essence for this Agreement, the COUNTY will suffer financial loss if the work is not completed within the time specified. The COUNTY will be entitled to assess, as Liquidated Damages, but not as a penalty, for each calendar day after the scheduled completion date the Service continues. The Service will be deemed to be completed on the date the work is considered complete to the satisfaction of the COUNTY. The CONTRACTOR hereby expressly waives and relinquishes any right which it may have to seek to characterize the Liquidated Damages as a penalty. The parties agree that the Liquidated Damages sum represents a fair and reasonable estimate of the COUNTY'S actual damages at the time of contracting if the CONTRACTOR fails to complete the work in a timely manner.

**C.** The Liquidated Damages will be as set forth in the following table:

<b>Service/Project Amount</b>	<b>Daily Charge (Per Calendar Day)</b>
\$5,000 and under	\$25
Over \$5,000 but less than \$10,000	\$65
\$10,000 or more but less than \$20,000	\$91
\$20,000 or more but less than \$30,000	\$121
\$30,000 or more but less than \$40,000	\$166
\$40,000 or more but less than \$50,000	\$228
\$50,001 or more	\$250

**D.** The COUNTY will retain from the compensation to be paid to the CONTRACTOR the above-described sum. If CONTRACTOR is in default for not completing the Service within the time specified, the COUNTY may require CONTRACTOR to stop work on any other project or service to the COUNTY until the Service specific in this Agreement is complete and the Liquidated damages Sum is satisfied.

**6.18 Sanitation.** If the Service does not involve interior work, the CONTRACTOR shall provide and maintain adequate sanitary conveniences for the use of persons employed for the Service. These conveniences will be maintained at all times without nuisance, and their use must be strictly enforced. The location of these conveniences will be subject to the COUNTY'S Project Manager's approval. All such facilities will be installed and maintained in accordance with applicable Federal, State, and local laws.

**6.19 Submittals and Equal Products.**

**A.** Submittals of products required for the Service assigned to the CONTRACTOR under this Agreement, must be supplied to the COUNTY for pre-approval prior to the start of the work. These documents must be provided to the COUNTY at least one (1) week before the installation.

**B.** If a product or service requested by the COUNTY for the Service has been identified in the specifications by a brand name, and has not been notated as a “No Substitute,” item, such identification is intended to be descriptive and not restrictive, and is to indicate the quality and characteristics of product or service that will be acceptable. If the CONTRACTOR offers an alternate product or service for consideration, such product must be clearly identified by the CONTRACTOR to the COUNTY. The COUNTY shall make a determination whether the alternate meets the salient characteristics of the specifications. An alternate product will not be considered for any item notated “No Substitute.”

**C.** Unless the CONTRACTOR clearly indicates in its response that it is proposing an alternate product, the response will be considered as offering the same brand name referenced in the specifications. If the CONTRACTOR proposes to furnish an alternate product or service, the brand name of the product or service to be furnished must be clearly identified. A formal submittal for the alternate/shop drawings must be submitted. The evaluation of the alternate and the determination as to acceptability of the alternate product or service will be the responsibility of the COUNTY and will be based upon information furnished by the CONTRACTOR. The COUNTY will not be responsible for locating or securing any information which is not included in the CONTRACTOR’s response. To ensure that sufficient information is available, the CONTRACTOR will furnish as part of the bid or proposal all descriptive material by providing the manufacturer specification sheets so the COUNTY can make an informed determination whether the product offered meets the salient characteristics required by the specifications. Failure to do so will require the use of the specified products.

**6.20 Fees.** The following is a list of fees that may be assessed to CONTRACTOR during the term of this Agreement. These fees are assessed to help offset the additional costs associated with the COUNTY’S labor and vehicle usage required for unnecessary inspections or missed appointments. The \$80.00 fee shown below is a re-inspection fee for uncorrected workmanship. The fee will be applied to the third inspection and for any subsequent inspections. Any re-inspection fee charged to the COUNTY by other agencies having jurisdiction over the Service, will additionally be charged back to CONTRACTOR. The fees, if any, will be deducted from the final invoices.

Missing scheduled appointments	\$70.00 each occurrence
Failure to respond to emergency calls	\$250.00 per day
Late to emergency calls	\$36.00 per hour
Inspected unacceptable workmanship	\$80.00 each inspection
Failure to provide any and all required documentation or reports	\$75.00 per day
Failure to pass all inspecting authority re-inspections (within 30 days of initial inspection)	\$250.00 per day

**ARTICLE 7. SPECIAL TERMS AND CONDITIONS.**

**7.1 Termination.**

**A. Termination for Convenience.** This Agreement may be terminated by the COUNTY upon thirty (30) calendar days’ written notice to the CONTRACTOR; but if any work, service or task under this Agreement is in progress but not completed on the date of termination, then this Agreement may be extended upon written approval of the COUNTY until the work, service, or task is completed and accepted. In the event this Agreement is terminated or cancelled upon the request and for the convenience of the COUNTY with the required thirty (30) calendar days’ written notice, the COUNTY will reimburse the CONTRACTOR for actual work satisfactorily completed.

**B. Termination for Cause.** This Agreement may be terminated by the COUNTY due to the CONTRACTOR'S breach of a material term of this Agreement, but only after the COUNTY has provided CONTRACTOR with ten (10) calendar days' written notice for the CONTRACTOR to cure the breach and the CONTRACTOR'S failure to cure the breach within that ten (10) day time period; but, if any work, service or task under this Agreement is in progress but not completed on the date of termination, then this Agreement may be extended upon written approval of the COUNTY until the work, service, or task is completed and accepted.

**C. Termination Due to Unavailability of Funds in Succeeding Fiscal Years.** When funds are not appropriated or otherwise made available to support continuation of performance in a subsequent fiscal year, this Agreement will be terminated and the CONTRACTOR will be reimbursed for the reasonable value of any non-recurring costs incurred but not amortized in the price of the supplies or services/tasks delivered under this Agreement.

**7.2 Insurance.**

**A.** CONTRACTOR will purchase and maintain at all times during the term of this Contract, without cost or expense to the COUNTY, policies of insurance as indicated below, with a company or companies authorized to do business in the State of Florida, and which are acceptable to the COUNTY, insuring the CONTRACTOR against any and all claims, demands, or causes of action, for injuries received or damage to property relating to the performance of duties, services, or obligations of the CONTRACTOR under the terms and provisions of the Contract. An original certificate of insurance, indicating that CONTRACTOR has coverage in accordance with the requirements of this section must be received and accepted by the COUNTY prior to contract execution or before any work begins. It will be furnished by CONTRACTOR to the COUNTY'S Project Manager and Procurement Services Director within five working days of such request.

The parties agree that the policies of insurance and confirming certificates of insurance will insure the CONTRACTOR in accordance with the following minimum limits:

**i.** General Liability insurance on forms no more restrictive than the latest edition of the Occurrence Form Commercial General Liability policy (CG 00 01) of the Insurance Services Office or equivalent without restrictive endorsements, with the following minimum limits and coverage:

Each Occurrence/General Aggregate .....	\$1,000,000/2,000,000
Products-Completed Operations .....	\$2,000,000
Personal & Adv. Injury .....	\$1,000,000
Fire Damage.....	\$50,000
Medical Expense .....	\$5,000
Contractual Liability .....	Included
Marine General Liability.....	Included

**ii.** Automobile liability insurance, including owned, non-owned, and hired autos with the minimum Combined Single Limit of \$1,000,000

**iii.** Workers' compensation insurance based on proper reporting of classification codes and payroll amounts in accordance with Chapter 440, Florida Statutes, and any other applicable law requiring workers' compensation (Federal, maritime, etc.).

AGREEMENT BETWEEN LAKE COUNTY, FLORIDA AND FOR CONSTRUCTION OF THE FERNDALDE PRESERVE  
OBSERVATION TOWER, PIER, AND CANOE LAUNCH (ARPA FUNDED); ITB #24-925

Longshore & Harbor Workers Coverage Endorsement..... \$1,000,000

iv. Employers Liability with the following minimum limits and coverage:

Each Accident..... \$1,000,000  
Disease-Each Employer ..... \$1,000,000  
Disease-Policy Limit..... \$1,000,000

v. Specialty insurance with the following minimum limits and coverage:

Pollution Liability Coverage ..... \$1,000,000/\$2,000,000  
Builders Risk Policy, Property, All Risk ..... \$3,200,000

**B.** Lake County, a Political Subdivision of the State of Florida, and the Board of County Commissioners, will be named as additional insured as their interest may appear all applicable policies. Certificates of insurance must identify the RFP or ITB number in the Description of Operations section on the Certificate.

**C.** CONTRACTOR must provide a minimum of thirty (30) days prior written notice to the COUNTY of any change, cancellation, or nonrenewal of the required insurance.

**D.** Certificates of insurance must evidence a waiver of subrogation in favor of the COUNTY, that coverage must be primary and noncontributory, and that each evidenced policy includes a Cross Liability or Severability of Interests provision, with no requirement of premium by the COUNTY.

**E.** CONTRACTOR must provide a copy of all policy endorsements, reflecting the required coverage, with Lake County listed as an additional insured along with all required provisions to include waiver of subrogation. Contracts cannot be completed without this required insurance documentation. **A certificate of insurance (COI) will not be accepted in lieu of the policy endorsements.**

**F.** Certificate holder must be:  
LAKE COUNTY, A POLITICAL SUBDIVISION OF THE STATE OF FLORIDA, AND  
THE BOARD OF COUNTY COMMISSIONERS.  
P.O. BOX 7800  
TAVARES, FL 32778-7800

**G.** All self-insured retentions will appear on the certificates and will be subject to approval by the COUNTY. At the option of the COUNTY, the insurer will reduce or eliminate such self-insured retentions; or CONTRACTOR will be required to procure a bond guaranteeing payment of losses and related claims expenses.

**H.** The COUNTY will be exempt from, and in no way liable for, any sums of money, which may represent a deductible or self-insured retention in any insurance policy. The payment of such deductible or self-insured retention will be the sole responsibility of the CONTRACTOR or subcontractor providing such insurance.

**I.** CONTRACTOR will be responsible for subcontractors and their insurance. subcontractors are to provide Certificates of Insurance to the COUNTY evidencing coverage and terms in accordance with the CONTRACTOR'S requirements.

**J.** Failure to obtain and maintain such insurance as set out above will be considered a breach of contract and may result in termination of the contract for default.

**K.** Neither approval by the COUNTY of any insurance supplied by CONTRACTOR, nor a failure to disapprove that insurance, will relieve CONTRACTOR of full responsibility of liability, damages, and accidents as set forth herein.

**7.3** Indemnity. To the extent permitted by law, the CONTRACTOR shall indemnify and hold harmless the COUNTY and its officers, employees, agents and instrumentalities from any and all liability, losses or damages, including attorneys' fees and costs of defense, which the COUNTY or its officers, employees, agents or instrumentalities may incur as a result of claims, demands, suits, causes of actions or proceedings of any kind or nature arising out of, relating to or resulting from the performance of the Contract by the CONTRACTOR or its employees, agents, servants, partners, principals, or subcontractors. The CONTRACTOR shall pay all claims and losses in connection with those claims and losses, and shall investigate and defend all claims, suits or actions of any kind or nature in the name of the COUNTY, where applicable, including appellate proceedings, and shall pay all costs, judgments, and attorneys' fees which may be incurred. The CONTRACTOR expressly understands and agrees that any insurance protection required by the Contract or otherwise provided by the CONTRACTOR will in no way limit the responsibility to indemnify, keep and hold harmless and defend the COUNTY or its officers, employees, agents, and instrumentalities as provided in a solicitation or any Contract arising from a solicitation. The indemnification obligation shall not be construed to negate, abridge, or reduce any other rights or remedies which otherwise may be available to an indemnified Party or person described in this paragraph or be deemed to affect the rights, privileges, and immunities of the COUNTY as set forth in Section 768.28, Florida Statutes.

**7.4** Independent Contractor. The CONTRACTOR, and all its employees, agree that they will be acting as independent contractors and will not be considered or deemed to be an agent, employee, joint venturer, or partner of the COUNTY. The CONTRACTOR will have no authority to contract for or bind the COUNTY in any manner and shall not represent itself as an agent of the COUNTY or as otherwise authorized to act for or on behalf of the COUNTY. Additionally, the CONTRACTOR warrants that it has not employed or retained any company or person, other than a bona fide employee working solely for the CONTRACTOR to solicit or secure this Agreement and that it has not paid or agreed to pay any person, company, corporation, individual, or firm other than a bona fide employee working solely for the CONTRACTOR any fee, commission, percentage, gift, or other consideration contingent upon or resulting from the award or making of this Agreement.

**7.5** Return of Materials. Upon the request of the COUNTY, but in any event upon termination of this Agreement, the CONTRACTOR shall surrender to the COUNTY all memoranda, notes, records, drawings, manuals, computer software, and other documents or materials pertaining to the services under this Agreement, that were furnished to the CONTRACTOR by the COUNTY pursuant to this Agreement.

**7.6** Public Entity Crimes. A person or affiliate who has been placed on the convicted vendor list following a conviction of a public entity crime may not be awarded or perform work as a CONTRACTOR, supplier, subcontractor, or consultant under a contract with any public entity in excess of the threshold amount provided in Florida Statutes, Section 287.017, for Category Two for a period of thirty-six (36) months from the date of being placed on the convicted vendor list.

**7.7** Conflict of Interest. The CONTRACTOR agrees that it will not engage in any action that would create a conflict of interest in the performance of its obligations pursuant to this Agreement, or which would violate or cause others to violate the provisions of Part III, Chapter 112, Florida Statutes, relating to ethics

in government. Further, the CONTRACTOR hereby certifies that no officer, agent, or employee of the COUNTY has any material interest either directly or indirectly in the business of the CONTRACTOR conducted here and that no such person may have any such interest at any time during the term of this Agreement unless approved by the COUNTY.

**7.8** Retaining Other Contractors. Nothing in this Agreement will be deemed to preclude the COUNTY from retaining the services of other persons or entities undertaking the same or similar services as those undertaken by the CONTRACTOR or from independently developing or acquiring materials or programs that are similar to, or competitive with, the services provided under this Agreement.

**7.9** While the COUNTY has listed all major items which are utilized by COUNTY departments in conjunction with their operations, there may be similar or ancillary items that must be purchased by the COUNTY during the term of this Agreement. Under these circumstances, a COUNTY representative will contact the CONTRACTOR to obtain a price quote for the similar or ancillary items. The COUNTY reserves the right to award these ancillary items to the CONTRACTOR, another vendor based on the lowest price quoted, or to acquire the items through a separate solicitation.

**7.10** Accuracy. The CONTRACTOR is responsible for the professional quality, technical accuracy, timely completion, and coordination of all the services furnished under this Agreement. The CONTRACTOR shall, without additional compensation, correct or revise any errors, omissions, or other deficiencies resulting from the services provided in this Agreement.

**7.11** Additional Services. Services not specifically identified in this Agreement may be added to the Agreement upon execution of a written amendment. The COUNTY reserves the right to award any additional services to the CONTRACTOR or to acquire the items from another vendor through a separate solicitation.

**7.12** Right to Audit. The COUNTY reserves the right to require the CONTRACTOR to submit to an audit by any auditor of the COUNTY'S choosing. The CONTRACTOR shall provide access to all of its records, which relate directly or indirectly to this Agreement at its place of business during regular business hours. The CONTRACTOR shall retain all records pertaining to this Agreement and upon request make them available to the COUNTY for five (5) years following expiration of the Agreement, or for such time as set forth in the Florida Department of State, Division of Library and Information Services, General Records Schedule GS1-SL, a copy of which can be found at: <https://dos.fl.gov/library-archives/records-management/general-records-schedules/>, whichever is longer. **If Federal retention standards under the ARPA grant require retention periods longer than those required the State of Florida, records will be retained for the longer period.** The CONTRACTOR agrees to provide such assistance as may be necessary to facilitate the review or audit by the COUNTY to ensure compliance with applicable accounting and financial standards.

**A.** If the CONTRACTOR provides technology services, the CONTRACTOR must provide Statement of Standards for Attestations Engagements (SSAE) 16 or 18 and System and Service Organization Control (SOC) reports upon request by the COUNTY. The SOC reports must be full Type II reports that include the CONTRACTOR'S description of control processes, and the independent auditor's evaluation of the design and operating effectiveness of controls. The cost of the reports will be paid by the CONTRACTOR.

**B.** If an audit inspection or examination pursuant to this section discloses overpricing or overcharges of any nature by the CONTRACTOR to the COUNTY in excess of one percent (1%) of the total contract billings, in addition to making adjustments for the overcharges, the reasonable actual cost of



the COUNTY'S audit must be reimbursed to the COUNTY by the CONTRACTOR. Any adjustments or payments which must be made as a result of any such audit or inspection of the CONTRACTOR'S invoices or records must be made within a reasonable amount of time, but in no event may the time exceed ninety (90) calendar days, from presentation of the COUNTY'S audit findings to the CONTRACTOR.

C. This provision is hereby considered to be included within, and applicable to, any subcontractor contract entered into by the CONTRACTOR in performance of any work under this Agreement.

### 7.13 Public Records.

A. All electronic files, audio and video recordings, and all papers pertaining to any activity performed by the CONTRACTOR for or on behalf of the COUNTY will be the property of the COUNTY and will be turned over to the COUNTY upon request. In accordance with Chapter 119, Florida Statutes, each file and all papers pertaining to any activities performed for or on behalf of the COUNTY are public records available for inspection by any person even if the file or paper resides in the CONTRACTOR'S office or facility. The CONTRACTOR will maintain the files and papers for not less than three complete calendar years after the Service has been completed or terminated, or in accordance with any grant requirements, whichever is longer. Prior to the close out of this Agreement, the CONTRACTOR will appoint a records custodian to handle any records request and provide the custodian's name and telephone numbers to the COUNTY'S Project Manager.

B. Pursuant to Section 119.0701, Florida Statutes, CONTRACTOR will comply with the Florida Public Records' laws, and will:

1. Keep and maintain public records required by the COUNTY to perform the services identified herein.

2. Upon request from the COUNTY'S custodian of public records, provide the COUNTY with a copy of the requested records or allow the records to be inspected or copied within a reasonable time at a cost that does not exceed the cost provided for by law.

3. Ensure that public records that are exempt or confidential and exempt from public records disclosure requirements are not disclosed except as authorized by law for the duration of the contract term and following completion of the contract if the CONTRACTOR does not transfer the records to the COUNTY.

4. Upon completion of this Agreement, transfer, at no cost, to the COUNTY all public records in possession of the CONTRACTOR or keep and maintain public records required by the COUNTY to perform the service. If CONTRACTOR transfers all public records to the COUNTY upon completion of the contract, CONTRACTOR will destroy any duplicate public records that are exempt, or confidential and exempt, from public records disclosure requirements. If CONTRACTOR keeps and maintains public records upon completion of the Agreement, CONTRACTOR will meet all applicable requirements for retaining public records. All records stored electronically must be provided to the COUNTY, upon request from the COUNTY'S custodian of public records, in a format that is compatible with the information technology systems of the COUNTY.

**C. IF CONTRACTOR HAS QUESTIONS REGARDING THE APPLICATION OF CHAPTER 119, FLORIDA STATUTES, TO CONTRACTOR'S DUTY TO PROVIDE PUBLIC RECORDS RELATING TO THIS AGREEMENT, CONTACT THE CUSTODIAN OF PUBLIC RECORDS AT LAKE COUNTY OFFICE OF PROCUREMENT SERVICES, 315 WEST MAIN STREET, P.O. BOX 7800, TAVARES, FL 32778 OR AT 352-343-9424 OR VIA EMAIL AT [PURCHASING@LAKECOUNTYFL.GOV](mailto:PURCHASING@LAKECOUNTYFL.GOV).**

**D.** Failure to comply with this subsection will be deemed a breach of the Agreement and enforceable as set forth in Section 119.0701, Florida Statutes.

**E.** Unless otherwise provided, CONTRACTOR shall maintain substantiating records as required by the State of Florida, General Records Schedule GS1-SL ("Schedule") for State and Local Government Agencies. If CONTRACTOR receives notification of a dispute or the commencement of litigation regarding the Project within the time specified in the Schedule, the CONTRACTOR shall continue to maintain all service records until final resolution of the dispute or litigation.

**F. Confidential and/or Exempt Information.** The Service includes building plans, blueprints, drawings, and/or diagrams which are exempt from disclosure pursuant to Section 119.071(3) Florida Statutes. CONTRACTOR must maintain the confidential and/or exempt nature of all confidential and/or exempt documents received under this Service. Upon completion of the Service, CONTRACTOR will return to COUNTY all confidential and/or exempt project documents including, but not limited to, designs, files, photos, reports, maps, drawings, specifications, schematics, diagrams, shop drawings, construction documents and electronic files. CONTRACTOR will provide written certification to COUNTY that all documents designated as confidential and/or exempt have been returned to the COUNTY or destroyed.

**7.14 Force Majeure.** The parties will exercise every reasonable effort to meet their respective obligations under this Agreement, but will not be liable for delays resulting from force majeure or other causes beyond their reasonable control, including, but not limited to, compliance with any Government law or regulation, acts of nature, acts or omissions of the other party, Government acts or omissions, fires, strikes, national disasters, wars, riots, transportation problems and any other cause whatsoever beyond the reasonable control of the parties. Any such cause will extend the performance of the delayed obligation to the extent of the delay so Incurred.

**7.15 Business Hours of Operation.** Unless otherwise specified in the technical specifications, all work performed must be accomplished between the hours of 8:00 A.M. and 5:00 P.M., Monday through Friday, and no work may be performed on Saturdays, Sundays, or County Holidays, unless permission to work has been requested in writing by the CONTRACTOR and approval, in writing, has been granted by the COUNTY. Request for permission to work must be received by the COUNTY no less than two (2) days prior to the requested workday. The exception to this pre-approval requirement would be in the case of an emergency in which the emergency specification as outlined in General Terms and Conditions, Section 3, Emergencies, would apply. County Holidays are as follows: New Year's Day; Martin Luther King, Jr. Day; Presidents' Day; Memorial Day; Independence Day; Labor Day; Veteran's Day; Thanksgiving Day; Day after Thanksgiving; and Christmas Day.

Special schedules may be established, if necessary, because of problems with noise or similar difficulties affecting other COUNTY facilities, COUNTY operations, or citizens in homes or buildings/rooms adjacent to the work being completed. When the CONTRACTOR requests and is approved for Saturday, Sunday or Holiday work, the COUNTY may assess the CONTRACTOR the sum of Two Hundred Fifty and 00/100 Dollars (\$250.00) per COUNTY staff member per day for each Saturday, Sunday or recognized Holiday worked or planned to work. These fees will be deducted from the final invoice.

**7.16 Minimum Wage.** The wage rate paid to all laborers, mechanics, and apprentices employed by the CONTRACTOR for the work under the Agreement may not be less than the prevailing wage rates for similar classifications of work as established by the Federal government and enforced by the U.S. Department of Labor, Wages and Hours Division, and Florida's Minimum Wage requirements in Article X, Section 24(f) of the Florida Constitution and enforced by the Florida Legislature by statute or the State Agency for Workforce Innovation by rule, whichever is higher.

**7.17 Protection of Property.** All existing structures, utilities, services, roads, trees, shrubbery and property in which the COUNTY has an interest must be protected against damage or interrupted services at all times by the CONTRACTOR during the term of this contract, and the CONTRACTOR will be held responsible for repairing or replacing damaged property to the satisfaction of the COUNTY which is damaged by reason of the CONTRACTOR'S operation on the property. In the event the CONTRACTOR fails to comply with these requirements, the COUNTY reserves the right to secure the required services and charge the costs of such services back to the CONTRACTOR. All items damaged as a result of CONTRACTOR or subcontractor operations belonging to third parties, such as but not limited to: sidewalks, irrigation, curbs, pipes, drains, water mains, pavement, mailboxes, turf, signs, or other property must either be repaired or replaced by the CONTRACTOR, at the CONTRACTOR'S expense, in a manner prescribed by, and at the sole satisfaction of the COUNTY.

Furthermore, the CONTRACTOR shall repair or replace any portion of any of the COUNTY'S facility, whether interior or exterior, damaged by reason of the CONTRACTOR'S operation within the property. In the event the CONTRACTOR fails to comply with these requirements, the COUNTY reserves the right to secure the required services and charge the costs of such services back to the CONTRACTOR. All items within a facility belonging to third parties, or to commissioners, officers, employees, lessees, invitees, or agents of the COUNTY, including but not limited to personal items and furniture, must either be repaired or replaced by the CONTRACTOR, at the CONTRACTOR'S expense, in a manner prescribed by, and at the sole satisfaction of the COUNTY. The CONTRACTOR shall re-grade and re-sod any areas that are disturbed by the CONTRACTOR during the course of the work being completed.

**7.18 Lands for Work and Access Thereto.** CONTRACTOR hereby represents to COUNTY that it is fully aware of the limits of land for access to the work site and for the site proper. No storage or equipment shall take place on private property unless the CONTRACTOR has a letter from the landowner authorizing the CONTRACTOR to do so. CONTRACTOR is responsible for obtaining any required temporary use permits prior to utilizing the private property. A copy of the letter shall be provided to the COUNTY. The CONTRACTOR shall supply the Project Manager any such letter before the equipment is placed there. The CONTRACTOR shall obtain from landowner any environmental permits and use permits, as applicable, and supply a copy thereof to the COUNTY.

The CONTRACTOR shall, absent written permission from a private property owner, confine all storage of materials, equipment, and the operations of workers to the project site and land and areas identified in and permitted by the contract documents. The CONTRACTOR shall assume full responsibility for any damage to any such land or area or to the owner or occupant thereof, or any land or areas contiguous thereto, resulting from the performance of the work. At the completion of the work, the CONTRACTOR shall

remove all debris, rubbish and waste materials from and about the project site, as well as all tools, appliances, equipment, machinery, and surface materials and shall leave the project site clean. All service and supply operations shall be conducted outside the clear zone unless the CONTRACTOR has proper authorization and traffic control. No supply vehicles shall enter the median for any purpose. No service vehicles shall enter the median except when necessary to repair or remove inoperable equipment.

**7.19 Risk of Loss.** The CONTRACTOR assumes the risk of loss of damage to the COUNTY'S property during possession of such property by the CONTRACTOR, and until delivery to and acceptance of that property to the COUNTY. The CONTRACTOR shall immediately repair, replace or make good on the loss or damage without cost to the COUNTY, whether the loss or damage results from acts or omissions, negligent or otherwise, of the CONTRACTOR or a third party.

**7.20 Accident Notification.** If in the course of completing work as part of this Agreement there is any accident, including accidents which involve the public, the CONTRACTOR shall as soon as possible inform the COUNTY of the incident by telephone. The CONTRACTOR shall follow up in writing within two (2) business days of the incident. If law enforcement was involved and has written a report, the CONTRACTOR shall forward a copy of the report to the COUNTY.

**7.21 Licenses and Permits.** CONTRACTOR will be solely responsible for obtaining all necessary approvals and permits to complete the service, unless specifically agreed otherwise in the Scope of Services. The CONTRACTOR shall remain appropriately licensed throughout the course of the Service. If the CONTRACTOR employs the services of a subcontractor, the CONTRACTOR shall ensure that any subcontractor is appropriately licensed throughout the course of the Service. Failure to maintain all required licenses will entitle the COUNTY, at its option, to terminate this Agreement. Damages, penalties, or fines imposed on the COUNTY or CONTRACTOR for failure to obtain required licenses, permits, inspections, or other fees, or inspections, will be borne by the CONTRACTOR.

**7.22 Drawings/Plans.** If at any time the CONTRACTOR is supplied by the COUNTY or produces building drawings/documentation for construction or any other purpose, the CONTRACTOR shall not share, distribute, display, or in any other way transmit a copy of these plans without the consent of the COUNTY. If there is a need to allow another individual to view the plans, a written request (email is allowed) shall be submitted to the COUNTY'S Project Manager. A written response (email is allowed) from the COUNTY must be obtained before the plans can be released for viewing.

**7.23 Assignment of Agreement.** This Agreement may not be assigned except with the written consent of the COUNTY. No such consent will be construed as making the COUNTY a party to the assignment or subjecting the COUNTY to liability of any kind to any assignee. No assignment will under any circumstances relieve the CONTRACTOR of liability and obligations under this Agreement and all transactions with the COUNTY must be through the CONTRACTOR. Additionally, unless otherwise stipulated in this Agreement, the CONTRACTOR shall notify and obtain prior written consent from the COUNTY prior to being acquired or subject to a hostile takeover. Any acquisition or hostile takeover without the prior consent of the COUNTY may result in termination of this Agreement for default.

#### **ARTICLE 8. FEDERAL FUNDING PROVISIONS.**

The Service under this Agreement is funded by American Rescue Plan Act (ARPA) Coronavirus State and Local Fiscal Recovery Funds (SLFRF) from the U.S. Department of the Treasury (Treasury). CONTRACTOR agrees to comply with the requirements of the Treasury and the terms of the SLFRF Award. The following contract provisions are required by Appendix II to 2 CFR, Part 200 ("Uniform

Guidance") and the Treasury SLFRF Award terms. During the performance of this Agreement, the CONTRACTOR agrees as follows:

**8.1** Equal Employment Opportunity. During the performance of this Agreement, the CONTRACTOR agrees as follows (Federally Assisted Construction Contracts (as defined in 41 CFR § 60-1.3) that exceed \$10,000):

**A.** The CONTRACTOR will not discriminate against any employee or applicant for employment because of race, color, religion, sex, sexual orientation, gender identity, or national origin. The CONTRACTOR will take affirmative action to ensure that applicants are employed, and that employees are treated during employment, without regard to their race, color, religion, sex, sexual orientation, gender identity, or national origin. Such action shall include, but not be limited to the following: Employment, upgrading, demotion, or transfer, recruitment or recruitment advertising; layoff or termination; rates of pay or other forms of compensation; and selection for training, including apprenticeship. The CONTRACTOR agrees to post in conspicuous places, available to employees and applicants for employment, notices to be provided by the contracting officer setting forth the provisions of this nondiscrimination clause.

**B.** The CONTRACTOR will, in all solicitations or advertisements for employees placed by or on behalf of the CONTRACTOR, state that all qualified applicants will receive consideration for employment without regard to race, color, religion, sex, sexual orientation, gender identity, or national origin.

**C.** The CONTRACTOR will not discharge or in any other manner discriminate against any employee or applicant for employment because such employee or applicant has inquired about, discussed, or disclosed the compensation of the employee or applicant or another employee or applicant. This provision shall not apply to instances in which an employee who has access to the compensation information of other employees or applicants as a part of such employee's essential job functions discloses the compensation of such other employees or applicants to individuals who do not otherwise have access to such information, unless such disclosure is in response to a formal complaint or charge, in furtherance of an investigation, proceeding, hearing, or action, including an investigation conducted by the employer, or is consistent with the CONTRACTOR'S legal duty to furnish information.

**D.** The CONTRACTOR will send to each labor union or representative of workers with which it has a collective bargaining agreement or other contract or understanding, a notice to be provided by the agency contracting officer, advising the labor union or workers' representative of the CONTRACTOR'S commitments under section 202 of Executive Order 11246 of September 24, 1965, and shall post copies of the notice in conspicuous places available to employees and applicants for employment.

**E.** The CONTRACTOR will comply with all provisions of Executive Order 11246 of September 24, 1965, and of the rules, regulations, and relevant orders of the Secretary of Labor.

**F.** The CONTRACTOR will furnish all information and reports required by Executive Order 11246 of September 24, 1965, and by the rules, regulations, and orders of the Secretary of Labor, or pursuant thereto, and will permit access to his books, records, and accounts by the contracting agency and the Secretary of Labor for purposes of investigation to ascertain compliance with such rules, regulations, and orders.

**G.** In the event of the CONTRACTOR'S non-compliance with the nondiscrimination clauses of this contract or with any of such rules, regulations, or orders, this contract may be canceled, terminated or suspended in whole or in part and the CONTRACTOR may be declared ineligible for further Government

contracts in accordance with procedures authorized in Executive Order 11246 of September 24, 1965, and such other sanctions may be imposed and remedies invoked as provided in Executive Order 11246 of September 24, 1965, or by rule, regulation, or order of the Secretary of Labor, or as otherwise provided by law.

H. The CONTRACTOR will include the provisions of paragraphs 8.1(A) through (H) in every subcontract or purchase order unless exempted by rules, regulations, or orders of the Secretary of Labor issued pursuant to section 204 of Executive Order 11246 of September 24, 1965, so that such provisions will be binding upon each subcontractor or vendor. The CONTRACTOR will take such action with respect to any subcontract or purchase order as may be directed by the Secretary of Labor as a means of enforcing such provisions including sanctions for noncompliance: Provided, however, that in the event the CONTRACTOR becomes involved in, or is threatened with, litigation with a subcontractor or vendor as a result of such direction, the CONTRACTOR may request the United States to enter into such litigation to protect the interests of the United States. The CONTRACTOR further agrees that it will be bound by the above equal opportunity clause with respect to its own employment practices when it participates in federally assisted construction work: *Provided*, that if the CONTRACTOR so participating is a State or local government, the above equal opportunity clause is not applicable to any agency, instrumentality or subdivision of such government which does not participate in work on or under the contract. The COUNTY agrees that it will assist and cooperate actively with the administering agency and the Secretary of Labor in obtaining the compliance of contractors and subcontractors with the equal opportunity clause and the rules, regulations, and relevant orders of the Secretary of Labor, that it will furnish the administering agency and the Secretary of Labor such information as they may require for the supervision of such compliance, and that it will otherwise assist the administering agency in the discharge of the agency's primary responsibility for securing compliance. The COUNTY further agrees that it will refrain from entering into any contract or contract modification subject to Executive Order 11246 of September 24, 1965, with a CONTRACTOR or subcontractor debarred from, or who has not demonstrated eligibility for, Government contracts and federally assisted construction contracts pursuant to the Executive Order and will carry out such sanctions and penalties for violation of the equal opportunity clause as may be imposed upon contractors and subcontractors by the administering agency or the Secretary of Labor pursuant to Part II, Subpart D of the Executive Order. In addition, the CONTRACTOR agrees that if it fails or refuses to comply with these undertakings, the administering agency may take any or all of the following actions: Cancel, terminate, or suspend in whole or in part this grant (contract, loan, insurance, guarantee); refrain from extending any further assistance to the applicant under the program with respect to which the failure or refund occurred until satisfactory assurance of future compliance has been received from such applicant; and refer the case to the Department of Justice for appropriate legal proceedings.

8.2 Access to Records. The following access to records requirements apply to this Agreement:

A. CONTRACTOR agrees to provide COUNTY, the State of Florida, the Federal Awarding Agency Administrator, the Comptroller General of the United States, or any of their authorized representatives access to any books, documents, papers, and records of CONTRACTOR which are directly pertinent to this Agreement for the purposes of making audits, examinations, excerpts, and transcriptions.

B. CONTRACTOR agrees to permit any of the foregoing parties to reproduce by any means whatsoever or to copy excerpts and transcriptions as reasonably needed.

C. CONTRACTOR agrees to provide the Federal Awarding Agency Administrator or their authorized representatives' access to construction or other work sites pertaining to the work being completed under the Agreement.

D. CONTRACTOR agrees to retain records for the longer of the time required by Federal Awarding Agency Administrator or by the State of Florida, as set forth in the Florida Department of State, Division of Library and Information Services, General Records Schedule GS1-SL, a copy of which can be found at this link: <https://dos.fl.gov/library-archives/records-management/general-records-schedules/>.

**8.3** Contract Work Hours and Safety Standards Act (CWHSSA) Provisions, 29 CFR § 5.5(b).

A. Overtime requirements. No CONTRACTOR or subcontractor contracting for any part of the contract work which may require or involve the employment of laborers or mechanics shall require or permit any such laborer or mechanic in any workweek in which he or she is employed on such work to work in excess of forty (40) hours in such workweek unless such laborer or mechanic receives compensation at a rate not less than one and one-half times the basic rate of pay for all hours worked in excess of forty (40) hours in such workweek.

B. Violation; liability for unpaid wages; liquidated damages. In the event of any violation of the clause set forth in paragraph (1) of this section the CONTRACTOR and any subcontractor responsible therefor shall be liable for the unpaid wages. In addition, such CONTRACTOR and subcontractor shall be liable to the United States (in the case of work done under contract for the District of Columbia or a territory, to such District or to such territory), for liquidated damages. Such liquidated damages shall be computed with respect to each individual laborer or mechanic, including watchmen and guards, employed in violation of the clause set forth in paragraph (1) of this section, in the sum of \$27 for each calendar day on which such individual was required or permitted to work in excess of the standard workweek of forty (40) hours without payment of the overtime wages required by the clause set forth in paragraph (1) of this section.

C. Withholding for unpaid wages and liquidated damages. The COUNTY shall upon its own action or upon written request of an authorized representative of the Department of Labor withhold or cause to be withheld, from any moneys payable on account of work performed by the CONTRACTOR or subcontractor under any such contract or any other Federal contract with the same prime CONTRACTOR, or any other federally-assisted contract subject to the Contract Work Hours and Safety Standards Act, which is held by the same prime CONTRACTOR, such sums as may be determined to be necessary to satisfy any liabilities of such CONTRACTOR or subcontractor for unpaid wages and liquidated damages as provided in the clause set forth in paragraph (2) of this section.

D. Subcontracts. The CONTRACTOR or subcontractor shall insert in any subcontracts the clauses set forth in paragraph (1) through (4) of this section and also a clause requiring the subcontractors to include these clauses in any lower tier subcontracts. The prime CONTRACTOR shall be responsible for compliance by any subcontractor or lower tier subcontractor with the clauses set forth in paragraphs (1) through (4) of this section.

E. Exceptions. None of the requirements of this section shall apply if this Agreement is a contract (1) for transportation by land, air, or water; (2) for the transmission of intelligence; (3) for the purchase of supplies, materials, or articles ordinarily available in the open market; or (4) in an amount that is equal to or less than \$100,000.

**8.4** Health and Safety. The provisions of this section are applicable where the amount of the prime contract exceeds \$100,000.

A. No laborer or mechanic shall be required to work in surroundings or under working conditions which are unsanitary, hazardous, or dangerous to his health and safety as determined under construction safety and health standards promulgated by the Secretary of Labor by regulation.

B. The CONTRACTOR shall comply with all regulations issued by the Secretary of Labor pursuant to Title 29 Part 1926 and failure to comply may result in imposition of sanctions pursuant to the Contract Work Hours and Safety Standards Act, (Public Law 91- 54, 83 Stat 96). 40 U.S.C. 3701 et seq.

C. The CONTRACTOR shall include the provisions of this paragraph in every subcontract so that such provisions will be binding on each subcontractor. The CONTRACTOR shall take such action with respect to any subcontractor as the Secretary of Housing and Urban Development or the Secretary of Labor shall direct as a means of enforcing such provisions.

#### 8.5 Clean Air and Clean Water Acts.

A. Clean Air Act. This Agreement is subject to the requirements of the Clean Air Act, as amended, 42 U.S.C. 1857 et. seq., and the regulations of the Environmental Protection Agency with respect thereto, at 40 CFR Part 15, as amended from time to time.

The CONTRACTOR and any of its subcontractors for work funded under the Agreement which is in excess of one-hundred thousand (\$100,000) dollars agree to the following requirements:

1. A stipulation by the CONTRACTOR or subcontractors that any facility to be utilized in the performance of any nonexempt contract or subcontract is not listed on the List of Violating Facilities issued by the Environmental Protection Agency (EPA) pursuant to 40 CFR Part 15.20.

2. Agreement by the CONTRACTOR to comply with all the requirements of Section 114 of the Clean Air Act, as amended (42 U.S.C. 1857c-8) and (33 U.S.C. 1318) relating to the inspection, monitoring, entry reports and information as well as all other requirements specified in said Section 114 and Section 308, and all regulations, and guidelines issued thereunder.

3. A stipulation that as a condition for the award of the contract prompt notice will be given of any notification received from the Director, Office of Federal Activities, EPA, indicating that a facility utilized or to be utilized for the contract is under consideration to be listed on the EPA List of Violating Facilities.

4. Agreement by the CONTRACTOR that he/she will include or cause to be included the criteria and requirements in paragraph (1) through (4) of this section in every nonexempt subcontract and requiring that the CONTRACTOR will take such action as the Government may direct as a means of enforcing such provision.

B. Federal Water Pollution Control Act. The CONTRACTOR shall comply with all applicable standards, orders, and regulations issued pursuant to the Federal Water Pollution Control Act, 33 U.S.C., Section 1251, *et seq.* The CONTRACTOR shall report each violation to the COUNTY, which will report each violation as required to Federal Awarding Agency and the appropriate EPA Regional Office. The CONTRACTOR shall include these requirements in each subcontract exceeding \$100,000 financed in whole or in part with Federal assistance provided by Federal Awarding Agency under this Agreement.

C. In no event shall any amount of the assistance provided under this Agreement be utilized with respect to a facility which has given rise to a conviction under Section 113(c)(1) of the Clean Air Act or Section 309(c) of the Federal Water Pollution Control Act.



**8.6** Debarment and Suspension. A contract award (see 2 CFR 180.220) must not be made to parties listed on the government-wide exclusions in the System for Award Management (SAM), in accordance with the OMB guidelines at 2 CFR.180 that implement Executive Orders 12549 (3 CFR part 1986 Comp., p. 189) and 12689 (3 CFR part 1989 Comp., p. 235), "Debarment and Suspension." SAM Exclusions contains the names of parties debarred, suspended, or otherwise excluded by agencies, as well as parties declared ineligible under statutory or regulatory authority other than Executive Order 12549. Use [www.SAM.gov](http://www.SAM.gov). CONTRACTOR'S certification regarding debarment, suspension, ineligibility, and voluntary exclusion is a material representation upon which the contract award is based.

**A.** This Agreement is a covered transaction for purposes of 2 CFR pt. 180 and 2 CFR pt. 3000. As such the CONTRACTOR is required to verify that none of the CONTRACTOR, its principals (defined at 2 CFR § 180.995), or its affiliates (defined at 2 CFR § 180.905) are excluded (defined at 2 CFR § 180.940) or disqualified (defined at 2 CFR § 180.935).

**B.** The CONTRACTOR must comply with 2 CFR pt. 180, subpart C and 2 CFR pt. 3000, subpart C and must include a requirement to comply with these regulations in any lower tier covered transaction it enters into.

**C.** This certification is a material representation of fact relied upon by the COUNTY. If it is later determined that the CONTRACTOR did not comply with 2 CFR pt. 180, subpart C and 2 CFR pt. 3000, subpart C, in addition to remedies available to the State of Florida and, the Federal Government may pursue available remedies, including but not limited to suspension and/or debarment.

**D.** The CONTRACTOR agrees to comply with the requirements of 2 CFR pt. 180, subpart C and 2 CFR pt. 3000, subpart C, while this offer is valid and throughout the period of any contract that may arise from this offer. The CONTRACTOR further agrees to include a provision requiring such compliance in its lower tier covered transactions.

**8.7** Byrd Anti-Lobbying Amendment. CONTRACTOR has executed the certification regarding lobbying, and such is considered attached to and incorporated within this Agreement. CONTRACTORS who apply or bid for an award of \$100,000 or more shall file the required certification. Each tier certifies to the tier above that it will not and has not used Federal appropriated funds to pay any person or organization for influencing or attempting to influence an officer or employee of any agency, a member of Congress, officer or employee of Congress, or an employee of a member of Congress in connection with obtaining any Federal contract, grant, or any other award covered by 31 U.S.C. Section 1352. Each tier shall also disclose any lobbying with non-Federal funds that takes place in connection with obtaining any Federal award. Such disclosures are forwarded from tier to tier up to the recipient. CONTRACTOR also shall cause any Subcontractor with a Subcontract (at any Tier) exceeding \$100,000 to file with the Tier above it the certification in **Exhibit G**, which is attached hereto and incorporated herein.

**8.8** Procurement of Recovered Materials. In performance of this Agreement, the CONTRACTOR shall make maximum use of products containing recovered materials that are EPA-designated items unless the product cannot be acquired: (a) Competitively within a timeframe providing for compliance with the contract performance schedule; (b) Meeting contract performance requirements; or (c) At a reasonable price. Information about this requirement and the list of EPA designated items is available at EPA's Comprehensive Procurement Guidelines web site, <https://www.epa.gov/smm/comprehensive-procurement-guideline-cpg-program#products>. The CONTRACTOR also agrees to comply with all other applicable requirements of Section 6002 of the Solid Waste Disposal Act. This section shall apply if (1) this Contract involves the purchase of an item designated by the Environmental Protection Agency ("EPA")

in 40 CFR Part 247 that exceeds \$10,000 or (2) the total value of such designated items acquired during COUNTY'S preceding fiscal year exceeded \$10,000.

**8.9** Prohibition on Certain Telecommunications and Video Surveillance Services or Equipment.

**A.** Definitions. As used in this clause, the terms backhaul; covered foreign country; covered telecommunications equipment or services; interconnection arrangements; roaming; substantial or essential component; and telecommunications equipment or services have the meaning as defined in FEMA Policy 405-143-1, Prohibitions on Expending FEMA Award Funds for Covered Telecommunications Equipment or Services (Interim), as used in this clause.

**B.** Prohibitions.

**1.** Section 889(b) of the John S. McCain National Defense Authorization Act for Fiscal Year 2019, Pub. L. No. 115-232, and 2 CFR § 200.216 prohibit the head of an executive agency on or after August 13, 2020, from obligating or expending grant, cooperative agreement, loan, or loan guarantee funds on certain telecommunications products or from certain entities for national security reasons.

**2.** Unless an exception in paragraph 3 of this clause applies, the CONTRACTOR and its subcontractors may not use grant, cooperative agreement, loan, or loan guarantee funds from the Federal Emergency Management Agency to:

**i.** Procure or obtain any equipment, system, or service that uses covered telecommunications equipment or services as a substantial or essential component of any system, or as critical technology of any system;

**ii.** Enter into, extend, or renew a contract to procure or obtain any equipment, system, or service that uses covered telecommunications equipment or services as a substantial or essential component of any system, or as critical technology of any system;

**iii.** Enter into, extend, or renew contracts with entities that use covered telecommunications equipment or services as a substantial or essential component of any system, or as critical technology as part of any system; or

**iv.** Provide, as part of its performance of this contract, subcontract, or other contractual instrument, any equipment, system, or service that uses covered telecommunications equipment or services as a substantial or essential component of any system, or as critical technology as part of any system.

**C.** Exceptions.

**1.** This clause does not prohibit CONTRACTOR from providing:

**i.** A service that connects to the facilities of a third-party, such as backhaul, roaming, or interconnection arrangements; or

**ii.** Telecommunications equipment that cannot route or redirect user data traffic or permit visibility into any user data or packets that such equipment transmits or otherwise handles.

2. By necessary implication and regulation, the prohibitions also do not apply to:

i. Covered telecommunications equipment or services that:

a. Are not used as a substantial or essential component of any system; and

b. Are not used as critical technology of any system.

ii. Other telecommunications equipment or services that are not considered covered telecommunications equipment or services.

**D. Reporting requirement.**

1. In the event the CONTRACTOR identifies covered telecommunications equipment or services used as a substantial or essential component of any system, or as critical technology as part of any system, during contract performance, or the CONTRACTOR is notified of such by a subcontractor at any tier or by any other source, the CONTRACTOR shall report the information in paragraph D.2 of this clause to the recipient or subrecipient, unless elsewhere in this contract are established procedures for reporting the information.

2. The CONTRACTOR shall report the following information pursuant to paragraph D.1 of this clause:

i. Within one (1) business day from the date of such identification or notification: The contract number; the order number(s), if applicable; supplier name; supplier unique entity identifier (if known); supplier Commercial and Government Entity (CAGE) code (if known); brand; model number (original equipment manufacturer number, manufacturer part number, or wholesaler number); item description; and any readily available information about mitigation actions undertaken or recommended.

ii. Within ten (10) business days of submitting the information in paragraph 4.b.i of this clause: Any further available information about mitigation actions undertaken or recommended. In addition, the CONTRACTOR shall describe the efforts it undertook to prevent use or submission of covered telecommunications equipment or services, and any additional efforts that will be incorporated to prevent future use or submission of covered telecommunications equipment or services.

**E. Subcontracts.** The CONTRACTOR shall insert the substance of this clause, including this paragraph E, in all subcontracts and other contractual instruments.

**8.10 Copeland Anti-Kickback Act Compliance.** If required by a Federal Awarding Agency, CONTRACTOR agrees to comply with the Copeland "Anti-Kickback" Act (40 U.S.C. 3145), as supplemented by Department of Labor regulations (29 CFR Part 3, "Contractors and Subcontractors on Public Building or Public Work Financed in Whole or in Part by Loans or Grants from the United States"). CONTRACTOR is prohibited from inducing, by any means, any person employed in the construction, completion, or repair of public work, to give up any part of the compensation to which he or she is otherwise

entitled. The CONTRACTOR and the COUNTY must report all suspected or reported violations to the Federal awarding agency.

**8.11 Domestic Preferences for Procurements.** As appropriate and to the extent consistent with law, the non-Federal entity should, to the greatest extent practicable under a Federal award, provide a preference for the purchase, acquisition, or use of goods, products, or materials produced in the United States (including, but not limited to iron, aluminum, steel, cement, and other manufactured products). The requirements of this section must be included in all subawards including all contracts and purchase orders for work or products under this award.

For purposes of this section: (1) "Produced in the United States" means, for iron and steel products, that all manufacturing processes, from the initial melting stage through the application of coatings, occurred in the United States. (2) "Manufactured products" means items and construction materials composed in whole or in part of non-ferrous metals such as aluminum; plastics and polymer-based products such as polyvinyl chloride pipe; aggregates such as concrete; glass, including optical fiber; and lumber.

**8.12 Solicitation of Minority and Women-Owned Business Enterprises (2 CFR § 200.321).** If CONTRACTOR intends to let any subcontracts, CONTRACTOR shall (1) place qualified small and minority businesses and women's business enterprises on its solicitation lists; (2) assure that small and minority businesses and women's business enterprises are solicited whenever they are potential sources; (3) divide total requirements, when economically feasible, into smaller tasks or quantities to permit maximum participation by small and minority businesses and women's business enterprises; and (4) establish delivery schedules, where the requirement permits, which encourage participation by small and minority businesses and women's business enterprises.

**8.13 Federal Participation.** The Federal Government is not a party to this contract and is not subject to any obligations or liabilities to the non-Federal entity, contractor, or any other party pertaining to any matter resulting from the contract.

**8.14 Compliance with Federal Law, Regulations, and Executive Orders.** The CONTRACTOR will comply with all applicable federal law, regulations, executive orders, Federal Awarding Agency policies, procedures, and directives.

**8.15 Federal Awarding Agency Seal, Logo, and Flags.** The CONTRACTOR shall not use the Federal Awarding Agency's seal(s), logos, crests, or reproductions of flags or likenesses of agency officials without specific Federal Awarding Agency preapproval.

**8.16 Program Fraud and False or Fraudulent Statements or Related Acts.** The CONTRACTOR acknowledges that 31 U.S.C. Chap. 38 (Administrative Remedies for False Claims and Statements) applies to the CONTRACTOR'S actions pertaining to this Agreement.

**8.17 Assurances of Compliance with Title VI of the Civil Rights Act of 1964.** CONTRACTOR and any subcontractor, or the successor, transferee, or assignee of CONTRACTOR or any subcontractor, shall comply with Title VI of the Civil Rights Act of 1964, which prohibits recipients of federal financial assistance from excluding from a program or activity, denying benefits of, or otherwise discriminating against a person on the basis of race, color, or national origin (42 U.S.C. §§ 2000d et seq.), as implemented by the Department of the Treasury's Title VI regulations, 31 CFR Part 22, which are herein incorporated by reference and made a part of this Agreement. Title VI also provides protection to persons with "Limited English Proficiency" in any program or activity receiving federal financial assistance, 42 U.S.C. §§ 2000d

et seq., as implemented by Treasury's Title VI regulations, 31 CFR. Part 22, and herein incorporated by reference and made a part of this Agreement.

**8.18 Civil Rights.** Statutes and regulations prohibiting discrimination applicable to this award, include, without limitation, the following:

**A.** Title VI of the Civil Rights Act of 1964 (42 U.S.C. §§ 2000d et seq.) and Treasury's implementing regulations at 31 CFR Part 22, which prohibit discrimination on the basis of race, color, or national origin under programs or activities receiving federal financial assistance;

**B.** The Fair Housing Act, Title VIII of the Civil Rights Act of 1968 (42 U.S.C. §§ 3601 et seq.), which prohibits discrimination in housing on the basis of race, color, religion, national origin, sex, familial status, or disability;

**C.** Section 504 of the Rehabilitation Act of 1973, as amended (29 U.S.C. § 794), which prohibits discrimination on the basis of disability under any program or activity receiving federal financial assistance;

**D.** The Age Discrimination Act of 1975, as amended (42 U.S.C. §§ 6101 et seq.), and Treasury's implementing regulations at 31 CFR Part 23, which prohibit discrimination on the basis of age in programs or activities receiving federal financial assistance; and

**E.** Title II of the Americans with Disabilities Act of 1990, as amended (42 U.S.C. §§ 12101 et seq.), which prohibits discrimination on the basis of disability under programs, activities, and services provided or made available by state and local governments or instrumentalities or agencies thereto.

**8.19 Restrictive Drawings and Specifications.** In accordance with 2 CFR 200.319 and agreements between the COUNTY and Federal Awarding Agency, the Agreement shall not require the use of materials, products or services that unduly restrict competition.

**8.20 Lead Based Paint Requirements.** Title IV of the Lead-Based Paint Poisoning Prevention Act (42 U.S.C. 4831) prohibits the use of lead- based paint in residential structures constructed or rehabilitated with Federal Assistance in any form.

**8.21 Drug-Free Workplace.** Subrecipient shall comply with the applicable provisions of the Drug-Free Workplace Act of 1988 (41 U.S.C. 701, et seq.) and Federal Awarding Agency's implementing regulations at 2 CFR part 2429.

**8.22 Hatch Act.** CONTRACTOR agrees to comply, as applicable, with requirements of the Hatch Act (5 U.S.C. §§ 1501-1508 and 7324-7328), which limit certain political activities of State or local government employees whose principal employment is in connection with an activity financed in whole or in part by this federal assistance.

**8.23 Protections for Whistleblowers.**

**A.** In accordance with 41 U.S.C. § 4712, CONTRACTOR may not discharge, demote, or otherwise discriminate against an employee in reprisal for disclosing to any of the list of persons or entities provided below, information that the employee reasonably believes is evidence of gross mismanagement

of a federal contract or grant, a gross waste of federal funds, an abuse of authority relating to a federal contract or grant, a substantial and specific danger to public health or safety, or a violation of law, rule, or regulation related to a federal contract (including the competition for or negotiation of a contract) or grant.

- B. The list of persons and entities referenced in the paragraph above includes the following:
1. A member of Congress or a representative of a committee of Congress;
  2. An Inspector General;
  3. The Government Accountability Office;
  4. A Treasury employee responsible for contract or grant oversight or management;
  5. An authorized official of the Department of Justice or other law enforcement agency;
  6. A court or grand jury; or
  7. A management official or other employee of Recipient, contractor, or subcontractor who has the responsibility to investigate, discover, or address misconduct.

C. CONTRACTOR shall inform its employees in writing of the rights and remedies provided under this section, in the predominant native language of the workforce.

**8.24 Increasing Seat Belt Use in the United States.** Pursuant to Executive Order 13043, 62 FR 19217 (Apr. 18, 1997), Recipient should encourage its contractors to adopt and enforce on-the-job seat belt policies and programs for their employees when operating company-owned, rented or personally owned vehicles.

**8.25 Reducing Text Messaging While Driving.** Pursuant to Executive Order 13513, 74 FR 51225 (Oct. 6, 2009), Recipient should encourage its employees, subrecipients, and contractors to adopt and enforce policies that ban text messaging while driving, and Recipient should establish workplace safety policies to decrease accidents caused by distracted drivers.

## **ARTICLE 9. MISCELLANEOUS PROVISIONS.**

**9.1 Governing Law, Venue, and Waiver of Jury Trial.** This Agreement is made under, and in all respects shall be interpreted, construed, and governed by and in accordance with, the laws of the State of Florida. Venue for any legal action resulting from this Agreement shall lie in Lake County, Florida. THE CONTRACTOR, BY ENTERING INTO THIS AGREEMENT, KNOWINGLY AND VOLUNTARILY WAIVES ANY RIGHT IT MAY HAVE TO A JURY TRIAL IN ANY CIVIL LITIGATION MATTER ARISING FROM OR RELATING TO THIS AGREEMENT.

**9.2 Captions.** The captions utilized in this Agreement are for the purposes of identification only and do not control or affect the meaning or construction of any of the provisions of this Agreement.

**9.3** This Agreement will be binding upon and will inure to the benefit of each of the parties and of their respective successors and permitted assigns.

**9.4** This Agreement may not be amended, released, discharged, rescinded or abandoned, except by a written instrument duly executed by each of the parties.

**9.5** The failure of any party at any time to enforce any of the provisions of this Agreement will in no way constitute or be construed as a waiver of such provision or of any other provision of this Agreement, nor in any way affect the validity of, or the right to enforce, each and every provision of this Agreement.

9.6 Construction of Agreement. The Parties intend this Agreement to be construed without regard to any presumption or rule requiring construction or interpretation against the Party drafting an instrument or causing any instrument to be drafted.

9.7 Civil Rights Act. During the term of this Agreement the CONTRACTOR assures the COUNTY that it is in compliance with Title VII of the 1964 Civil Rights Act, as amended, and the Florida Civil Rights Act of 1992, in that the CONTRACTOR does not on the grounds of race, color, national origin, religion, sex, age, disability or marital status, discriminate in any form or manner against the CONTRACTOR'S employees or applicants for employment. The CONTRACTOR understands and agrees that this Agreement is conditioned upon the veracity of this statement of assurance.

9.8 Compliance with Applicable Laws. The CONTRACTOR must at all times comply with all Federal, State and local laws, rules and regulations.

9.9 Negation of Agent or Employee Status. The employees of the CONTRACTOR will be considered at all times its employees and not an employee or agent of the COUNTY. The CONTRACTOR will provide employees capable of performing the work as required. The COUNTY may require the CONTRACTOR to remove any employee it deems unacceptable.

9.10 Fraud, misrepresentation, and material misstatements. Any individual, corporation, or other entity that attempts to meet its contractual obligations with the COUNTY through fraud, misrepresentation or material misstatement, may be debarred for up to five (5) years. The COUNTY as a further sanction may terminate or cancel any other contracts with such individual, corporation, or entity. Such individual or entity will be responsible for all direct or indirect costs associated with termination or cancellation, including attorney's fees.

9.11 Certification Regarding Scrutinized Companies that Boycott Israel: The CONTRACTOR hereby certifies that, pursuant to Section 287.135, Florida Statutes, it is not listed on the Scrutinized Companies that Boycott Israel and is not participating in a boycott of Israel. The CONTRACTOR understands that pursuant to Section 287.135, Florida Statutes, the submission of a false certification may subject it to civil penalties, attorneys' fees, and costs. The CONTRACTOR further understands that any contract with the COUNTY for goods or services may be terminated at the option of the COUNTY if the CONTRACTOR is found to have submitted a false certification or has been listed on the Scrutinized Companies that Boycott Israel list or is participating in a boycott of Israel.

The CONTRACTOR, by entering this Agreement, hereby certifies that, pursuant to Section 287.135, Florida Statutes, it is not listed on the Scrutinized Companies with activities in the Iran Petroleum Energy Sector List, or the Scrutinized Companies with Activities in Sudan List, is not listed on the Scrutinized Companies that Boycott Israel and is not participating in a boycott of Israel, and is not engaged in business operations in Cuba or Syria. The CONTRACTOR understands that pursuant to Section 287.135, Florida Statutes, the submission of a false certification may subject it to civil penalties, attorneys' fees, and costs. The CONTRACTOR further understands that any contract with the COUNTY for goods or services of \$1 million or more may be terminated at the option of the COUNTY if the CONTRACTOR is found to have submitted a false certification or has been listed on the Scrutinized Companies with activities in the Iran Petroleum Energy Sector List or the Scrutinized Companies with Activities in Sudan List, is listed on the Scrutinized Companies that Boycott Israel list or is participating in a boycott of Israel, or is engaged in business operations in Cuba or Syria.

**9.12** Florida Convicted/Suspended/Discriminatory Vendor Lists. By executing this Agreement CONTRACTOR affirms that it is not currently listed in the Florida Department of Management Services Convicted/Suspended/Discriminatory Complaint Vendor List.

**9.13** Discriminatory Vendor List. As provided by Section 287.134, Florida Statutes, a contractor who has been placed on the discriminatory vendor list may not submit a bid, proposal, or reply on a contract to provide any goods or services to a public entity; may not submit a bid, proposal, or reply on a contract with a public entity for the construction or repair of a public building or public work; may not submit bids, proposals, or replies on leases of real property to a public entity; may not be awarded or perform work as a contractor, supplier, subcontractor, or consultant under a contract with any public entity; and may not transact business with any public entity. By entering into this Agreement, CONTRACTOR affirms that CONTRACTOR is not on the Discriminatory Vendor List and will ensure that any subcontractors retained for performance under this Agreement are not listed on the Discriminatory Vendor List.

**9.14** Foreign gifts and contracts. Pursuant to Section 286.101, Florida Statutes, CONTRACTOR shall disclose to the COUNTY any current or prior interest of, any contract with, or any grant or gift received by a foreign country of concern if such interest, contract, or grant or gift (1) had a value of \$50,000 or more and (2) such interest existed at any time or such contract or grant or gift was received or in force at any time during the previous five (5) years. Foreign country of concern is defined in Section 286.101(1)(b), Florida Statutes, as the People's Republic of China, the Russian Federation, the Islamic Republic of Iran, the Democratic People's Republic of Korea, the Republic of Cuba, the Venezuelan regime of Nicolás Maduro, or the Syrian Arab Republic, including any agency of or any other entity under significant control of such foreign country of concern. CONTRACTOR'S disclosure must include the amount of the contract or grant or gift or the value of the interest disclosed, the applicable foreign country of concern and, if applicable, the date of termination of the contract or interest, the date of receipt of the grant or gift, and the name of the agent or controlled entity that is the source or interest holder. The COUNTY may request records relevant to a reasonable suspicion that a disclosure has not been made and the CONTRACTOR shall provide the required records within thirty (30) days of the COUNTY making such request, or at a later time as agreed to by the Parties.

**9.15** Contracting with foreign entities of concern. Pursuant to Section 287.138, Florida Statutes, for contracts where CONTRACTOR may have access to personal identifying information, CONTRACTOR certifies to the COUNTY by submitting its bid that (1) it is not owned by a government of a foreign country of concern; (2) a government of a foreign country of concern does not have a controlling interest in vendor; and (3) it is not organized under the law of nor has its principal place of business in a foreign country of concern. For the purposes of this section, foreign country of concern means the People's Republic of China, the Russian Federation, the Islamic Republic of Iran, the Democratic People's Republic of Korea, the Republic of Cuba, the Venezuelan regime of Nicolás Maduro, or the Syrian Arab Republic, including any agency of or any other entity of significant control of such foreign country of concern, as defined in Section 287.138(1)(c), Florida Statutes.

**9.16** Social, political, or ideological interests. Per Section 287.05701, Florida Statutes, the COUNTY will not request documentation of or consider a vendor's social, political, or ideological interests when determining if the vendor is a responsible vendor.

**9.17** Disadvantaged Businesses. The COUNTY has adopted policies which assure and encourage the full participation of Disadvantaged Business Enterprises (DBE) in the provision of goods and services. The COUNTY encourages joint ventures between majority-owned firms and qualified disadvantaged/minority/women-owned firms.



**9.18 Anti-Trafficking Related Activities.** The U.S. Government has adopted a policy prohibiting trafficking in persons including the trafficking-related activities listed below. These prohibitions specifically apply to some federally funded contracts and prohibit contractors, contractor employees, and their agents from:

- A. Engaging in severe forms of trafficking in persons during the period of performance of the contract;
- B. Procuring commercial sex acts during the period of performance of the contract;
- C. Using forced labor in the performance of the Agreement;
- D. Destroying, concealing, confiscating, or otherwise denying access by an employee to the employee's identity or immigration documents, such as passports or drivers' licenses, regardless of issuing authority;
- E. Using misleading or fraudulent practices during the recruitment of employees;
- F. Charging employees or potential employees recruitment fees;
- G. Failing to provide return transportation or paying for the cost of return transportation upon the end of employment for certain employees;
- H. Providing or arrange housing that fails to meet the host country housing and safety standards; or
- I. Failing to provide an employment contract, recruitment agreement, or other required work documents in writing, as required by law or contract.

**9.19 Prohibition against contingent fees.** CONTRACTOR, by entering this Agreement, warrants that they have not employed or retained any company or person, other than a bona fide employee working solely for the CONTRACTOR, to solicit or secure this Agreement and that they have not paid or agreed to pay any person, company, corporation, individual, or firm, other than a bona fide employee working solely for the CONTRACTOR, any consideration contingent upon or resulting from the award or making of this Agreement.

**9.20 Prime Contractor.** The CONTRACTOR will be the prime CONTRACTOR for all required items and services and will assume full responsibility for the procurement and maintenance of such items and services. The CONTRACTOR will be considered the sole point of contact with regards to all stipulations, including payment of all charges and meeting all requirements of this Agreement. All subcontractors will be subject to advance review by the COUNTY in terms of competency and security concerns. No change in subcontractors may be made without consent of the COUNTY. The CONTRACTOR will be responsible for all insurance, permits, licenses, and related matters for any and all subcontractors. Even if the subcontractor is self-insured, the COUNTY may require the CONTRACTOR to provide any insurance certificates required by the work to be performed.

**9.21 State Registration Requirements.** The CONTRACTOR shall either be registered or have applied for registration with the Florida Department of State in accordance with the provisions of Florida law, unless exempt from registration.

**9.22** Grant Funding. In the event that any part of this Agreement is to be funded with federal, state, or other local agency monies, the CONTRACTOR hereby agrees to comply with all requirements of the funding entity applicable to the use of the monies, including full application of requirements involving the use of minority-owned business enterprises, women-owned business enterprises, and labor surplus area firms. CONTRACTOR is advised that payments under this Agreement may be withheld pending completion and submission of all required forms and documents required of the CONTRACTOR pursuant to grant funding requirements. THIS AGREEMENT IS FUNDED UNDER THE AMERICAN RESCUE PLAN ACT (ARPA) STATE AND LOCAL FISCAL RECOVERY FUND (SLFRF) PROGRAM, ADMINISTERED BY THE U.S. DEPARTMENT OF TREASURY; CONTRACTOR MUST COMPLY WITH ALL FEDERAL REQUIREMENTS IN PROVIDING SERVICES UNDER THIS AGREEMENT.

**9.23** Continuation of Work. Any work that commences prior to and will extend beyond the expiration date of this Agreement, must, unless terminated by mutual agreement between COUNTY and CONTRACTOR, continue until completion without change to the then current prices, terms, and conditions.

**9.24** Sovereign Immunity. COUNTY expressly retains all rights, benefits, and immunities of sovereign immunity in accordance with Section 768.28, Florida Statutes. Nothing will be deemed as a waiver of immunity or the limitations of liability of COUNTY beyond any statutory limited waiver of immunity or limits of liability. Nothing will inure to the benefit of any third party for the purpose of allowing any claim against COUNTY, which would otherwise be barred under the law.

**9.25** Severability. The invalidity or unenforceability of any particular provision of this Agreement will not affect the other provisions of this Agreement, and this Agreement must be construed in all respects as if such invalid or unenforceable provisions were omitted.

**9.26** Notices. Wherever provision is made in this Agreement for the giving, service, or delivery of any notice, statement or other instrument, such notice must be in writing and will be deemed to have been duly given, served, and delivered, if delivered by hand or mailed by United States registered or certified mail, addressed as follows:

**AGREEMENT BETWEEN LAKE COUNTY, FLORIDA AND FOR CONSTRUCTION OF THE FERNDALE PRESERVE OBSERVATION TOWER, PIER, AND CANOE LAUNCH (ARPA FUNDED); ITB #24-925**

---

If to CONTRACTOR:

RUSH Marine, LLC  
Anthony Landry, President  
6285 Riverfront Center Blvd.  
Titusville, Florida 32780

If to COUNTY:

Lake County Manager  
Lake County Administration Building  
315 West Main Street  
P.O. Box 7800  
Tavares, Florida 32778

With a copy to:

County Attorney  
Lake County Administration Building  
315 West Main Street, Ste. 335  
P.O. Box 7800  
Tavares, Florida 32778

Each party may change its mailing address by giving to the other party, by hand delivery, United States registered or certified mail, notice of election to change such address.

**ARTICLE 10. SCOPE OF AGREEMENT.**

**10.1** This Agreement is intended by the parties to be the final expression of their Agreement, and it constitutes the full and entire understanding between the parties with respect to the subject of this Agreement, notwithstanding any representations, statements, or agreements to the contrary previously made. Any items not covered under this contract will need to be added via written addendum, and pricing negotiated based on final specifications.

**10.2** This Agreement includes the following exhibits, all of which are incorporated in this Agreement:

- Exhibit A (Composite).....Scope of Services, Addenda, and Submittal Form (19 pages).
- Exhibit B .....Pricing Sheet (1 page).
- Exhibit C (Composite).....Project Plans and Specifications (278 pages). **[PORTIONS EXEMPT PER SEC. 119.071(3)(b), FLA. STAT.]**
- Exhibit D.....Clarification on Launching, Parking, and Storage (2 pages).
- Exhibit E (Composite) .....Contractor's Payment Affidavit and Final Payment Affidavit (2 pages).
- Exhibit F.....Performance and Payment Bond (7 pages).
- Exhibit G.....Section 3 Business and Worker Certifications (1 pages).

AGREEMENT BETWEEN LAKE COUNTY, FLORIDA AND FOR CONSTRUCTION OF THE FERDALE PRESERVE  
OBSERVATION TOWER, PIER, AND CANOE LAUNCH (ARPA FUNDED); ITB #24-925

IN WITNESS WHEREOF, the Parties have made and executed this Agreement on the respective dates under each signature: the COUNTY through its Board of County Commissioners, signing by and through its Chairman; and by the CONTRACTOR through its duly authorized representative.

CONTRACTOR

RUSH MARINE, LLC

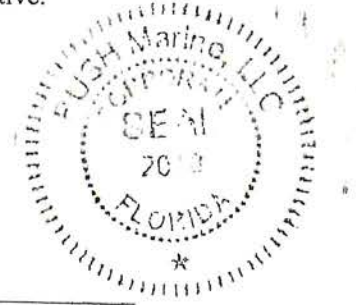

*Anthony Landry*

Anthony Landry, President  
(Qualifying Contractor's License No. CGC1526374, held  
by William C. Chivers, Jr., for RUSH Marine, LLC)

This 9<sup>th</sup> day of AUGUST, 2024.

AGREEMENT BETWEEN LAKE COUNTY, FLORIDA AND FOR CONSTRUCTION OF THE FERNDALE PRESERVE OBSERVATION TOWER, PIER, AND CANOE LAUNCH (ARPA FUNDED); ITB #24-925

COUNTY

LAKE COUNTY, FLORIDA, through its  
BOARD OF COUNTY COMMISSIONERS

  
\_\_\_\_\_  
Kirby Smith, Chairman

This 29<sup>th</sup> day of Aug, 2024.

ATTEST:

  
\_\_\_\_\_  
Gary Cooney, Clerk  
Board of County Commissioners  
of Lake County, Florida



Approved as to form and legality:

mmmarsh 8/27/24  
\_\_\_\_\_  
Melanie Marsh  
County Attorney

**Ferndale Preserve - Observation Tower, Fishing Pier & Canoe-Kayak Launch**

**1. SCOPE OF WORK**

A “qualified licensed contractor” (hereinafter “Contractor”) shall furnish all labor, materials, equipment, component/devices, transportation, fuel, supervision, surveying, permits, inspections, and all other incidentals necessary to complete all necessary work, all in accordance with all parts of this solicitation and Construction Documents provided in Exhibit E for the Ferndale Preserve, located at 19220 CR 455, Ferndale, FL, 34715.

**2. BASE BID ITEM #1**

Contractor to furnish and install a turn-key observation tower/fishing pier & canoe/kayak launch, including but not limited to the construction of a precast concrete boardwalk with railings, aluminum gangway and floating dock (aluminum full float dock) with canoe/kayak launch including transfer station, furnishing and installation of fire extinguishers with cabinet, installation of precast concrete piles, precast concrete deck, solar powered LED light fixtures, installation of floating turbidity barrier with weighted skirts and temporary signs.

**3. BASE BID ITEM #2**

Professional Archeologist: Contractor to provide the services of a professional archeologist who meets the "Archeology and Historic Preservation: Secretary of Interior's Standards and Guidelines" who shall be onsite during the initial ground disturbing activities. The professional archeologist shall be responsible for monitoring the staging areas and ground disturbance locations for significant archaeological deposits.

**4. CONTRACTOR RESPONSIBILITIES**

4.1. Contractor’s access to the construction site will be limited through Lake Apopka. Vehicular access over land to and from the site for construction purposes is prohibited.

4.2. Contractor is responsible for the installation of floating turbidity barrier as shown in Site Plan sheet #4 prior to start any construction activity. Depending on site conditions, the barrier closest to the shoreline may need to be replaced with a staked turbidity barrier. Contractor should be on notice that they are responsible for additional or changed Erosion and Sediment Control Best Management Practices that may be necessary for the project, as determined during the work.

4.3. Sediment, Erosion, and Turbidity Control: Prior to the initiation of any work, the contractor shall install erosion, sediment, and turbidity control measures along the perimeter of all work areas to prevent the displacement of fill material outside the work area into waters of the United States. The erosion, sediment, and turbidity control measures shall remain in place and be properly maintained until all authorized work is completed and the work areas are stabilized. Turbidity barriers shall remain in place until the turbidity levels within the work area return to ambient levels, in compliance with the ACOE permit and state water quality standards. Contractor shall maintain and use a properly calibrated turbidimeter on site and ensure that stormwater or turbidity discharges from the work area do not exceed surface water quality standards. Contractor shall be

**Ferndale Preserve - Observation Tower, Fishing Pier & Canoe-Kayak Launch**

responsible for compliance with state water quality standards and any additional NPDES permit requirements. The Contractor shall be responsible for ensuring erosion control devices/procedures are inspected and maintained daily during all phases of construction authorized by this permit until areas disturbed during construction are sufficiently stabilized to prevent erosion, siltation, and turbid discharges.

- 4.4. Archeological Site Protection: Contractor to install a construction temporary fence (composite or heavy-duty plastic warning/barrier or similar) and warning signs to identify and protect the archaeological site from construction activity. Fencing must be installed north/east of the archaeological site adjacent to the area of proposed concrete boardwalk. If any archaeological artifact is found during construction of the concrete boardwalk, then the contractor must immediately stop all work in the affected area and notify the archaeologist and Lake County Parks and Water Resources.
- 4.5. Temporary Signs: Installation of 2 temporary signs concerning manatees, as required by Exhibit G - U.S. Army Corps of Engineers Permit (Enclosure 6), shall be posted prior to and during all in-water project activities. All signs are to be removed by the contractor upon completion of the project. One sign which reads Caution: Boaters must be posted. A second sign measuring at least 8 ½" by 11" explaining the requirements for "Idle Speed/No Wake" and the shutdown of in-water operations must be posted in a location prominently visible to all personnel engaged in water-related activities. All work must be conducted in compliance with Florida Fish and Wildlife Conservation Commission's Standard Manatee Conditions for In-Water Work (2011).
- 4.6. The Contractor will be responsible for planning and providing signage as required to ensure the safety and security of the site from the public, including park neighbors and visitors, children, and staff, during construction as well as after park hours. Park must remain open for public use during work.
- 4.7. Contractor is responsible for the protection and preservation of species listed as threatened, endangered, or of special concern, including gopher tortoises, as well as wildlife, native plant materials and hardscapes during the course of construction.
- 4.8. Burning of trees is prohibited. Contractor will be responsible for removing and disposing of existing trees in a legal and proper manner as necessary for the construction of the proposed improvements. Removal of trees must strictly adhere to any tree preservation plans prepared for the site.
- 4.9. Contractor to remove and relocate existing fencing and park signs/kiosks as necessary for the construction of proposed park improvements.
- 4.10. Contractor is responsible for debris/trash management and must provide a dumpster or must remove all construction debris/discarded materials/trash on a daily basis. No

**Ferndale Preserve - Observation Tower, Fishing Pier & Canoe-Kayak Launch**

discarded construction material shall be dumped or remain on site unless contained within a dumpster provided by the Contractor. Dumpsters must be properly maintained to prevent overflow of debris.

- 4.11. Roof Material (Panels) for the observation tower must be aluminum (**no substitutions**) as specified in Exhibit F - Specifications, Section 07610 Metal Roofing, Part 2.2 Materials, subsection A. Galvalume steel or any other material will not be approved.
- 4.12. Floating Dock: Aluminum float (fully welded aluminum float frame filled with solid polyurethane foam core covering all bottom of the dock, no substitutions). High Density Polyethylene (HDPE) float and Polystyrene foam are not acceptable materials.
- 4.13. Lake County Parks and Water Resources has obtained Site Plan approval, U.S. Army Corps of Engineers Permit and Florida Department of Environmental Protection (FDEP) permit. Parks and Water Resources will provide to the contractor the approved site plan, permits and any other document in electronic format only. If hard copies are needed, then contractor will be responsible to obtain any hard copies at his own expense.
- 4.14. Lake County Parks and Water Resources will be providing the Building Permit (Plan Review Only) for the proposed improvements; however, the Office of Building Services has indicated Contractor will be required to complete a Building Permit Application prior to issuance of this Permit. In addition, the Contractor and any subcontractors must be added to the building permit and pay all related permit and inspection cost/fees for the required work included under this solicitation. Refer to Permit Requirements section below for additional requirements.
- 4.15. Contractor will be required to provide a timeline/work schedule and a detailed cost breakdown (schedule of values) at the preconstruction meeting for review which shall be the base for all payment applications.
- 4.16. Final Payment: A Certificate of Completion/Occupancy issued by the Office Building Services, (352) 343-9653, must be provided on or before submittal of the final payment application.

**5. ACCEPTANCE**

Lake County will review each installation to determine compliance prior to final acceptance of the work. Any work not installed in accordance with the plans and specifications and rejected by Lake County must be removed and replaced at the Contractor's expense.

**6. CLEANING**

Perform cleaning during installation of the work and upon completion of the work. Remove from site all excess materials, soil, debris, and equipment. Any spoils created from this work must become the property of the Contractor and must be disposed of in a legal and proper manner.



**Ferndale Preserve - Observation Tower, Fishing Pier & Canoe-Kayak Launch****7. FIELD CONDITIONS**

It is the responsibility of the Contractor to verify all site conditions before they submit their bid. Verify and coordinate all work to field locations and dimensions. Contractor is responsible for the installation of temporary construction fencing and signage to safely enclose the work area along with silt fencing for entire perimeter of site work.

**8. INSTALLATION**

8.1. Installation must be in accordance with the terms and conditions in this Invitation to Bid, construction documents provided under Exhibit E and as stated in the Scope of Services.

8.2. All work must meet all applicable Federal, State, and local building codes and must be performed by qualified licensed Contractors in their respective areas (electrical, mechanical, plumbing, fire, etc.). The Contractor must complete all work per Construction Documents including the associated specifications.

**9. LEAD TIME**

Any long lead item must be ordered within one (1) week of issuance of project purchase order. Proof of purchase will be required.

**10. PERMIT REQUIREMENTS**

Contractor is responsible for obtaining all necessary building permits and inspection approvals and paying all related cost/fees for the required work included under this solicitation. Contractor is also responsible for obtaining signed/sealed engineering building plans from an aluminum gangway and floating dock manufacturer at their own expense. Contractor is also responsible for obtaining directly from the engineering firm at their own expense, if needed, any necessary engineering drawings (CAD drawings, signed/sealed electronic plans or hard copies). Contractor must provide a copy of all obtained permits to Parks and Water Resources prior to the start of construction. Contractor is responsible for installing a Permit Posting Box Unit. Approved plans and permits must be available on site for the inspector. For questions regarding building permits and review processes please contact the Office of Building Services at (352) 343-9653.

**11. PRODUCT HANDLING**

The contractor is responsible for the proper packaging, shipping, handling, and storage of materials to be incorporated in the work, so as to ensure the preservation of the quality and fitness of the materials for proper installation as required by the contract documents. Products are to be delivered to the site in the manufacturer's containers or packaging. Contractor shall provide the following: storage containers for materials as necessary; sufficient manpower and equipment necessary to off load equipment/materials at jobsite per scheduled deliveries; and dumpsters for cardboard waste and packing debris. Contractor must store materials in secure, weather-protected area and provide adequate security to protect delivered and stored products from theft, vandalism, or damage during the installation. The Contractor is responsible for the return of all damaged products to manufacturer and the replacement of damaged items.

**Ferndale Preserve - Observation Tower, Fishing Pier & Canoe-Kayak Launch****12. PROPERTY REPLACEMENT**

Property at the site, including turf (rubber, sod), concrete pavement, asphalt, lime rock path, and fencing requiring movement during the course of construction, or any other damage due to the work performed by contractor must be reinstalled, repaired, or replaced before final payment is made.

**13. SAFETY PRECAUTIONS**

The Contractor is responsible for initiating, maintaining, and supervising all safety precautions in connection with the work continuously and throughout the contract term. The Contractor must erect and maintain all reasonable safeguards for safety and protection, including posting danger signs and other warning signs against hazards. It is the responsibility of the Contractor to provide a safe environment for park patrons and must monitor and maintain fencing/barricades to ensure continued safety.

Contractor acknowledges that the location of the work is on natural lands and adjacent to and on a natural water body and wetland areas. Contractor is solely responsible for ensuring safety related to any additional or unique hazards due to the nature of the work.

**14. USE OF SITE**

The Contractor must confine its operations at the site to areas permitted by law, ordinances, and permits. The Contractor must not unreasonably encumber the site with materials, equipment, or trailers. The Contractor shall not cause the entrance to be blocked or otherwise prevent reasonable access to the site, other working and parking areas, completed portions of the work and/or properties and storage areas. The Contractor will be given twenty-four (24) hours notice by the County to remove or relocate any materials, equipment, and trailers improperly placed on the site; if Contractor fails to remove or relocate the items within the twenty-four (24) hours provided, the County will remove the items at the Contractor's expense.

**15. UTILITIES**

Contractor is responsible for making appropriate contact to ensure utility locations have been marked prior to excavation and trenching. Call 811 before you dig ([www.Sunshine811.com](http://www.Sunshine811.com)). The Contractor must protect all utilities (including irrigation) encountered while performing its work. The Contractor must exercise due care when excavating around utilities and must restore any damaged utilities, at its own expense, to the same condition or better as existed prior to start of work.

**16. VENDOR SUBMITTAL**

Submit product data/specifications and shop drawings electronically to Parks and Water Resources for review and approval of all items of work. All submittals to be approved by the engineer/architect and/or Parks and Water Resources prior to Contractor delivering materials to job site and installation.

**17. AS-BUILT PLANS**

One (1) complete set of As-Built Plans (signed/sealed by a licensed professional) in hard copy and electronic format along with operation and maintenance manuals (if applicable) shall be supplied to the County upon completion of the work and before submitting final payment application. Refer to Exhibit E - Construction Documents, Structural Notes sheet S002, 316213 Precast Concrete Piles note #5 for additional As-Built Plans requirements.

**18. WARRANTY AND GUARANTEES**

18.1. Contractor must furnish the Parks and Water Resources with a signed minimum one (1) year warranty and maintenance program covering all systems for a minimum one (1) year from the date of final acceptance of the project by Lake County. The Contractor is responsible for securing warranties and guarantees for any materials, equipment, or fixtures to be incorporated into the project and must transfer all warranties to the County upon completion.

18.2. Contractor must provide written Roof Manufacturer Warranties/Guarantee/Certification in accordance with Exhibit F - Specifications, Section 07610 Metal Roofing, Part 1.04 Warranty and Certification including but not limited subsections A, B, C and D. Note that the following warranties and a guarantee are required.

18.2.1. Manufacturer's standard 25-Year No Dollar Limit Warranty weather-tightness warranty.

18.2.2. Manufacturer's written full 25-year non-prorated warranty, covering cracking, peeling and color fade of metal roofing, flashing and trim, all of which shall be products of the roofing manufacturer.

18.2.3. A 10-year workmanship guarantee, on the roofing installation and components.

**19. WORKMANSHIP**

19.1. All furnishings described in this solicitation must be installed by qualified tradesman. All installation work and materials to be per manufacturer's specifications, or as directed by the County's Representative.

19.2. All work and materials are subject to the approval of the County.

19.3. All products must be inspected by the County for damage and chipped or marred finish. Contractor must replace any damaged or rejected products at no additional cost to the County. The County's Representative may at his option authorize acceptance of chipped or scratched painted surfaces repaired by Contractor at their own risk.

Ferndale Preserve - Observation Tower, Fishing Pier & Canoe-Kayak Launch

20. "EQUAL" PRODUCT CAN BE CONSIDERED UPON RECEIPT OF SPECIFIED DATA

20.1. Vendors must submit any equivalent request two (2) weeks prior to bid opening. Failure to submit timely will make equivalent submittal non-responsive.

20.2. The manufacturer's name, brand name, and/or model number information contained in this solicitation are being used for the sole purpose of establishing the minimum requirement of level of quality, standard of performance, and design and is in no way intended to prohibit the offer of another manufacturer's items of equal material unless otherwise indicated elsewhere in this solicitation.

20.3. This specific solicitation requires submission of the following documentation to enable County evaluation of "equal" products:

- \_\_\_\_\_ : Product Information Sheets
- \_\_\_\_\_ : Product Samples with Initial Offer
- \_\_\_\_\_ : Product Samples Upon Specific Request
- \_\_\_\_\_ : Product Labels
- \_\_\_\_\_ : Performance Test Results

20.4. If an "equal" product may be considered by the County in accordance with this solicitation, the unit shall be equal in quality and standards of performance to the item specified in the solicitation. Where an "or equal" item is offered, and product information sheets are required, the initial offer must be accompanied with two (2) complete sets of product information sheets (such as factory specifications, standard manufacturer information sheets, catalogues, and brochures), and if required, two (2) copies of performance test results of the unit offered as an equal. Also, for product information submittals, all supporting documentation submitted by the vendor must in total meet the required specifications set forth in this solicitation. Where the standard product literature submitted with the offer provides information that does not comply with the specifications, the vendor shall state, in an official letter on corporate letterhead as part of their initial offer, the differences between the item they are specifically offering, and the equipment described by the standard product literature, to substantiate compliance to all of the specifications set forth in this solicitation. In such cases, any offer submitted with standard product literature but without the letter explaining compliance will result in the rejection of the offer for not meeting the solicitation specifications.

20.5 If samples of all "or equal" items bid are required for evaluation, such items are to be provided at no cost to the County, and should be submitted with the initial offer, or at the time of specific request. Failure to meet this requirement may result in your offer being rejected.

20.6 For "equal" products to be evaluated based on submission of product labels, the initial offer should be accompanied with labels indicating the specification and ingredients for

**EXHIBIT A – SCOPE OF WORK**

24-925

**Ferndale Preserve - Observation Tower, Fishing Pier & Canoe-Kayak Launch**

each “or equal” item offered. Failure to meet this requirement may result in your offer being rejected.

20.7 The County shall be sole judge of equality, based on the best interests of the County, and its decision in this regard shall be final. Items labeled "No Substitute" on the County's Bid/Proposal Submission Form are the only products that will be accepted under this solicitation.

*[The remainder of this page intentionally left blank]*



REAL FLORIDA • REAL CLOSE  
Office of Procurement Services

P.O. Box 7800 • 315 W. Main St., Suite 416 • Tavares, FL 32778

**SOLICITATION: Ferndale Preserve – Observation Tower, Fishing Pier & Canoe /Kayak Launch**  
03/21/2024

Vendors are responsible for the receipt and acknowledgement of all addenda to a solicitation. Confirm acknowledgement by including an electronically completed copy of this addendum with submittal. Failure to acknowledge each addendum may prevent the submittal from being considered for award.

THIS ADDENDUM DOES NOT CHANGE THE DATE FOR RECEIPT OF PROPOSALS.

**QUESTIONS/RESPONSES**

1. Question: What is the anticipated start time for the project?

Response: There is currently no projected project start time. There are many stages of approvals that the awarded contractor must complete before a start date can be determined. As those approvals approach completion, the contractor and the County will coordinate an appropriate project start date.

2. Question: What is the project budget?

Response: There is no projected budget for this project. Submitting contractor should build the project budget from the available bid documents, attachments, and addendums. Projected budget should be detailed and submitted by the Contractor using Attachment 1 – Pricing Form.

3. Question: Have all fees been paid for the USACE and FDEP permits?

Response: There should be no additional fees for the awarded contractor.

4. Question: Exhibit A lists USACE and FDEP permits. Please provide a copy of the FDEP permit.

Response: Please see Exhibit J of this addendum for the ACOE permit. Please see Exhibit K of this addendum for the FDEP permit

5. Question: Reference Exhibit A 4.14 - What are the building permit fees for the building permit?

Response: The Fee Schedule for Building Permits are available to review at:  
[www.lakecountyfl.gov/board-of-county-commissioners/fee-schedules](http://www.lakecountyfl.gov/board-of-county-commissioners/fee-schedules)

6. Question: Exhibit A #10 states the contractor is responsible for obtaining from the engineering firm at their own expense engineering drawings. CAD drawings will be required for the layout/survey and signed/sealed drawings will be required for permit application. What are the exact fees the engineering firms will charge for these files? If these documents are not provided by the Owner, bidders will have to add costs to cover these fees which may be unnecessary. Additionally, there are multiple engineering firms included in the construction plans and given

that we are unable to contact anyone, but the contact listed in the bid document, there is no way for the bidders to accurately price these fees/costs.

The County's Design Team listed on the Construction Documents will provide documents to supplement the General Contractor in their work, without additional charges. The statement in the exhibit is intended to require that any additional engineering drawing or documentation, such as from an aluminum gangway or floating dock manufacturer, shall be at the General Contractor's expense. The County cannot predict the fee for the awarded contractor's in-house or subcontracted engineer to provide these additional services. Bidding Contractor will be responsible for sourcing these services and including the associated fees in the total pricing of their bid package submission.

7. Question: Exhibit A #10 states the contractor is responsible for obtaining from the engineering firm at their own expense engineering drawings. Please identify what other engineering may be needed other than what has already been completed and shown in the construction plans or is identified to be signed, sealed by delegate engineer(s). This is a vague requirement that could result in unnecessary contingency amounts being included in bid prices.

Response: Please refer to Exhibit L – Shop Drawings for Specialty Engineered Products to highlight specification 013302 on sheet S-001 for a list of specialty-engineered products that are considered delegated design.

8. Question: There are multiple references in the plans to a building and building components that are not shown elsewhere on the drawings. Please confirm there is no enclosed building structure included as part of the scope of work other than the observation tower.

Response: Confirmed, there may be references in general notes which could seemingly reference interior building components (i.e. General Notes on sheet A1.1), there are no enclosed buildings included in this scope of work other than the observation tower / fishing pier and canoe / kayak launch.

9. Question: Sheet S002 – Precast concrete piles #7 – is geotechnical oversight required during all installation of concrete piles or will periodic observation suffice?

Response: Please refer to specification 316213 for pile QC / inspection requirements as well as Sheet S002 – notes 316213. Reports with all requested information outlined should be provided and reviewed – it does not require continuous field observation by the Geotech engineer – only review of the reports to confirm compliance with design documents. More details are provided by viewing Exhibit M – Geotechnical Investigation of this addendum.

**ADDITIONAL INFORMATION**

10. The following exhibits are hereby added to the solicitation documents:

Exhibit J – ACOE Permit

Exhibit K – FDEP Permit

Exhibit L – Shop Drawings for Specialty Engineered Products

Exhibit M – Geotechnical Investigation

---

**ACKNOWLEDGEMENT**

**ADDENDUM NO. 1**

**24-925**

Firm Name: RUSH Marine, LLC

I hereby certify that my electronic signature has the same legal effect as if made under oath; that I am an authorized representative of this vendor and/or empowered to execute this submittal on behalf of the vendor.

Signature of Legal Representative Submitting this Bid: *Anthony Landry*

Date: 5/1/2024

Print Name: Anthony Landry

Title: President

Primary E-mail Address: tlandry@rushinc.com

Secondary E-mail Address: Click or tap here to enter text.





Office of Procurement Services

P.O. Box 7800 • 315 W. Main St., Suite 416 • Tavares, FL 32778

**SOLICITATION: Ferndale Preserve – Observation Tower, Fishing Pier & Canoe /Kayak Launch**  
03/28/2024

Vendors are responsible for the receipt and acknowledgement of all addenda to a solicitation. Confirm acknowledgement by including an electronically completed copy of this addendum with submittal. Failure to acknowledge each addendum may prevent the submittal from being considered for award.

THIS ADDENDUM CHANGES THE DATE FOR THE RECEIPT OF PROPOSALS TO  
APRIL 24, 2024 @ 3:00PM (EST)

---

**ACKNOWLEDGEMENT**

Firm Name: RUSH Marine, LLC

I hereby certify that my electronic signature has the same legal effect as if made under oath; that I am an authorized representative of this vendor and/or empowered to execute this submittal on behalf of the vendor.

Signature of Legal Representative Submitting this Bid: *Anthony Landry*

Date: 5/1/2024

Print Name: Anthony Landry

Title: President

Primary E-mail Address: tlandry@rushinc.com

Secondary E-mail Address: Click or tap here to enter text.



REAL FLORIDA • REAL CLOSE  
Office of Procurement Services

P.O. Box 7800 • 315 W. Main St., Suite 416 • Tavares, FL 32778

**SOLICITATION: Ferndale Preserve – Observation Tower, Fishing Pier & Canoe /Kayak Launch**  
04/18/2024

Vendors are responsible for the receipt and acknowledgement of all addenda to a solicitation. Confirm acknowledgement by including an electronically completed copy of this addendum with submittal. Failure to acknowledge each addendum may prevent the submittal from being considered for award.

THIS ADDENDUM CHANGES THE DATE FOR RECEIPT OF PROPOSALS TO  
MAY 1, 2024 @3:00 PM (EST)

**QUESTIONS/RESPONSES**

1. Question: What is the proposed thickness or gauge of the stainless mesh for the railing sections?

Response: Minimum .0120” wire type 304 stainless steel wire mesh.

2. Question: Can you provide the connection details between the stainless-steel mesh and aluminum railing?

Response: Please utilize the following railing connection detail as the basis of design. Final railing fabrication shall be by railing designer.

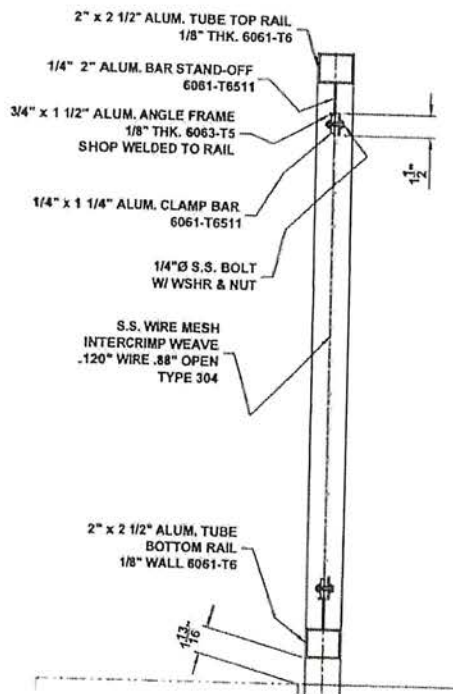

3. Question: Is it the Counties intent to fabricate the rail in approximately 8' sections?

Response: No, 8'-0" is the spacing between columns, which is to far of a span between railing panels. Railing panels are anticipated to be fabricated in 4'-0" sections, or two (2) sections per bay. It is understood that this may fluctuate in certain areas, for instance, between column grid lines 8 & 9.

4. Question: While speaking with a few different fabricators regarding the railing, we had the following comments and/or concerns expressed. The first fabricator's engineer is concerned that the wire mesh isn't strong enough to keep a pedestrian from through the mesh should they fall into the rail section. They have provided another option which is to use stainless steel perforated screen. An example is attached for consideration.

Response: The design intent is to match the railing which was utilized at the Green Mountain Scenic Overlook & Trailhead, located at 20700 County Road 455, Minneola, Florida 34715.

5. Question: The second fabricator had concerns of differing metals and the stainless-steel mesh significantly staining the aluminum rails due to oxidation. They are proposing the aluminum railing with a powder coated 2" x 2" aluminum mesh in lieu of stainless steel. Would this option be acceptable?

Response: Please refer to the detail below (same detail provided in response to previous question above). The mesh is separated from the powder coated aluminum railing by an aluminum bar stand-off & angle frame which is shop welded to the rail. Stainless steel mesh is preferred.

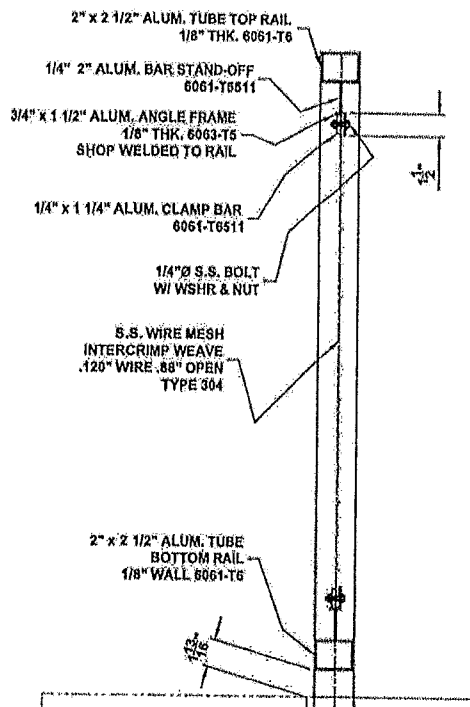

ACKNOWLEDGEMENT

Firm Name: RUSH Marine, LLC

I hereby certify that my electronic signature has the same legal effect as if made under oath; that I am an authorized representative of this vendor and/or empowered to execute this submittal on behalf of the vendor.

Signature of Legal Representative Submitting this Bid: *Anthony Landry*

Date: 5/1/2024

Print Name: Anthony Landry

Title: President

Primary E-mail Address: tlandry@rushinc.com

Secondary E-mail Address: Click or tap here to enter text.



Office of Procurement Services

P.O. Box 7800 • 315 W. Main St., Suite 416 • Tavares, FL 32778

**SOLICITATION: Ferndale Preserve - Observation Tower, Fishing Pier and Canoe/Kayak Launch**

04/22/2024.

Vendors are responsible for the receipt and acknowledgement of all addenda to a solicitation. Confirm acknowledgement by including an electronically completed copy of this addendum with submittal. Failure to acknowledge each addendum may prevent the submittal from being considered for award.

THIS ADDENDUM DOES NOT CHANGE THE DATE FOR RECEIPT OF PROPOSALS.

**ADDITIONAL INFORMATION**

Exhibit N – Clarifications on Launching, Parking and Storage is hereby added to the solicitation documents.

Exhibit O – Clarifications on Required Materials is hereby added to the solicitation documents.

---

**ACKNOWLEDGEMENT**

Firm Name: RUSH Marine, LLC

I hereby certify that my electronic signature has the same legal effect as if made under oath; that I am an authorized representative of this vendor and/or empowered to execute this submittal on behalf of the vendor.

Signature of Legal Representative Submitting this Bid: *Anthony Landry*

Date: 5/1/2024

Print Name: Anthony Landry

Title: President

Primary E-mail Address: tlandry@rushinc.com

Secondary E-mail Address: Click or tap here to enter text.

The undersigned hereby declares that: RUSH Marine, LLC has examined and accepts the specifications, terms, and conditions presented in this Solicitation, satisfies all legal requirements to do business with County, and to furnish **FERNDALE PRESERVE – OBSERVATION TOWER, FISHING PIER AND CANOE/KAYAK LAUNCH** for which Submittals were advertised to be received no later than 3:00 P.M. Eastern time on the date stated in the solicitation or as noted in an addenda. Furthermore, the undersigned is duly authorized to execute this document and any contracts or other transactions required by award of this Solicitation.

### 1.0 TERM OF CONTRACT

Contract will commence upon the related Notice to Proceed. Contract remains in effect until completion of the expressed and implied warranty periods. County reserves the right to negotiate for additional services/items similar in nature not known at time of solicitation.

### 2.0 PAYMENT

Contractor shall email County's using department an accurate invoice within 30 calendar days after delivery. Invoices shall reference the: purchase/task order, delivery date, delivery location, and corresponding packing slip or delivery ticket signed by a County representative at the time of acceptance. Failure to submit invoices in the prescribed manner will delay payment.

Payments will be tendered in accordance with the Florida Prompt Payment Act, Part VII, Chapter 218, Florida Statutes. County will remit full payment on all undisputed invoices within 45 days from receipt by the appropriate County using department. County will pay interest not to exceed 1% per month on all undisputed invoices not paid within 30 days after the due date.

All pricing will be FOB Destination unless otherwise specified in this solicitation document. Pricing submitted will remain valid for a ninety (90) day period.

### 3.0 CERTIFICATION REGARDING LAKE COUNTY TERMS AND CONDITIONS

I certify that I have reviewed the [General Terms and Conditions for Lake County Florida](#) and accept the Lake County General Terms and Conditions dated 5/6/21 as written including the Proprietary/Confidential Information section. YES

Failure to acknowledge may result in Submittal being deemed non-responsive.

### 4.0 CERTIFICATION REGARDING FELONY CONVICTION

Has any officer, director, or an executive performing equivalent duties, of the bidding entity been convicted of a felony during the past ten (10) years? NO

### 5.0 CONFLICT OF INTEREST DISCLOSURE CERTIFICATION

Except as listed below, no employee, officer, or agent of the firm has any conflicts of interest, real or apparent, due to ownership, other clients, contracts, or interests associated with this project; and, this Submittal is made without prior understanding, agreement, or connection with any corporation, firm, or person submitting a proposal for the same services, and is in all respects fair and without collusion or fraud. RUSH Marine, LLC

### 6.0 CERTIFICATION REGARDING BACKGROUND CHECKS

Under any County Contract that involves Contractor or subcontractor personnel working in proximity to minors, Vendor hereby confirms that any personnel so employed will have

successfully completed an initial, and subsequent annual, Certified Background Check, completed by Contractor at no additional cost to County. Vendor will comply with Florida Statutes regarding background investigations. County retains the right to request and review any associated records with or without cause, and to require replacement of any Contractor employee found in violation of this requirement. Contractor shall indemnify County in full for any adverse act of any such personnel in this regard. Additional requirements may apply in this regard as included within any specific contract award. YES

#### 7.0 DISADVANTAGED BUSINESS ENTERPRISE PROGRAM

County does not establish specific goals for minority set-asides however, participation by minority and non-minority qualified firms is strongly encouraged. If the firm is a minority firm or has obtained certification by the State of Florida, Office of Supplier Diversity, (OSD) (CMBE), please indicate the appropriate classification(s) not applicable not applicable and enter OSD Certification Number and enter effective date Click or tap to enter a date. to date Click or tap to enter a date.

#### 8.0 ANTITRUST VIOLATOR VENDOR LISTS

A person or an affiliate who has been placed on the antitrust violator vendor list following a conviction or being held civilly liable for an antitrust violation may not submit a bid, proposal, or reply for any new contract to provide any goods or services to a public entity; may not submit a bid, proposal, or reply for a new contract with a public entity for the construction or repair of a public building or public work; may not submit a bid, proposal, or reply on new leases of real property to a public entity; may not be awarded or perform work as a contractor, supplier, subcontractor, or consultant under a new contract with a public entity; and may not transact new business with a public entity.

#### 9.0 FEDERAL FUNDING REQUIREMENT

9.1. A contract award expected to equal or exceed \$25,000 or a contract award at any tier for a federally required audit (irrespective of the contract amount) must not be made to parties listed on the government-wide exclusions in the System for Award Management (SAM), in accordance with the OMB guidelines at 2 C.F.R. part 180. The Excluded Parties List System in SAM contains the names of parties debarred, suspended, or otherwise excluded by agencies, as well as parties declared ineligible under statutory or regulatory authority other than Executive Order 12549.

Recipients, contractors, and subcontractors (at any level) that enter into covered transactions are required to verify that the entity (as well as its principals and affiliates) with which they propose to contract or subcontract is not excluded or disqualified. This is done by: (a) checking the SAM exclusions; (b) collecting a certification from that person; or (c) adding a clause or condition to the contract or subcontract.

Registration or search can be conducted here: [SAM Directory and Registration website](#)

9.2. REQUIRED for this project – The System for Award Management (SAM.gov) Unique Entity ID [SAM.gov | Home](#): JJVBUKWKRW15

**10.0 RECIPROCAL VENDOR PREFERENCE**

N/A

**11.0 GENERAL VENDOR INFORMATION**

Firm Name: RUSH Marine, LLC

Street Address: 6285 Riverfront Center Blvd.

City: Titusville State and ZIP Code: Florida 32780

Mailing Address (if different): N/A

Telephone: 321-267-8100

Purchase Order Email Address: tlandry@rushinc.com

Federal Identification Number / TIN: 82-4091915

DUNS Number: 11-684-1595

**12.0 SUBMITTAL SIGNATURE**

I hereby certify the information indicated for this Submittal is true and accurate and that my electronic signature shall have the same legal effect as if made under oath; that I am an authorized representative of this Vendor and/or empowered to execute this Submittal on behalf of the Vendor. I, individually and on behalf of the Vendor, acknowledge and agree to abide by all terms and conditions contained in this solicitation as well as any attachments, exhibits, or addenda.

Name of Legal Representative Submitting this Proposal: *Anthony Landry*

Date: 5/1/2024

Print Name: Anthony Landry

Title: President

Primary E-mail Address: tlandry@rushinc.com

Secondary E-mail Address: Click or tap here to enter text.

The individual signing this Submittal affirms that the facts stated herein are true and that the response to this Solicitation has been submitted on behalf of the aforementioned Vendor.

*[The remainder of this page is intentionally blank]*



<b>RUSH Marine, LLC</b>			
<b>SAVE AND SUBMIT AS AN EXCEL FILE</b>			
Contractor to furnish all labor, materials, tools, transportation, and equipment necessary to provide services in accordance with specifications listed and implied. Actual hours are unknown and estimated for evaluation purposes only.			
Alterations to locked cells may result in disqualification of submission.			
ITEM #	ITEM DESCRIPTION	PROPOSED TIME FRAME (CALENDAR DAYS)	LUMP SUM PRICE
1	<p><b>BASE BID:</b> Lump Sum Price to furnish and install a turn-key observation tower/fishing pier &amp; canoe/kayak launch, including but not limited to the construction of a precast concrete boardwalk with railings, aluminum gangway and floating dock (aluminum full float dock) with canoe/kayak launch including transfer station, furnishing and installation of fire extinguishers with cabinet, installation of precast concrete piles, precast concrete deck, solar powered LED light fixtures, installation of floating turbidity barrier with weighted skirts and temporary signs.</p>	273 (Two Hundred Seventy-Three Calendar Days)	\$3,116,674.00
2	<p><b>Professional Archeologist:</b> Contractor to provide the services of a professional archeologist who meets the "Archeology and Historic Preservation: Secretary of Interior's Standards and Guidelines" who shall be onsite during the initial ground disturbing activities. The professional archeologist shall be responsible for monitoring the staging areas and ground disturbance locations for significant archaeological deposits.</p>		\$37,014.00
<b>TOTAL COST:</b>			<b>\$3,153,688.00</b>

Lake County is exempt from all taxes (Federal, State, Local). A Tax Exemption Certificate will be furnished upon request for any direct purchasing. Contractor will be responsible for payment of taxes on all materials purchased by the Contractor for the project.

EXHIBIT C (COMPOSITE)

FERNDALE PRESERVE OBSERVATION TOWER, PIER, AND CANOE LAUNCH  
CONSTRUCTION PLANS & SPECIFICATIONS

- PORTIONS OF EXHIBIT C EXEMPT PER SECTION 119.071(3), FLORIDA STATUTES –

The below listed items are incorporated into this contract as essential and material terms but shall be transmitted and kept on a separate CD-ROM due to the size of the files and due to the exempt nature of some of the documents indicated pursuant to Section 119.071(3), Florida Statutes.

1. *Ferndale Preserve Observation Tower / Fishing Pier and Canoe / Kayak Launch Construction Plans*, dated May 2022, prepared by Halff Associates, Inc., for Lake County (28 pages). [PORTIONS EXEMPT PER SEC. 119.071(3)(b), FLA. STAT.]
2. *Ferndale Preserve Observation Tower / Fishing Pier and Canoe/Kayak Launch Supplemental Specifications*, dated May 6, 2022, prepared by Powell Studio Architecture for Lake County (89 pages). [EXEMPT PER SEC. 119.071(3)(b), FLA. STAT.]
3. *013302 Shop Drawings for Specialty Engineered Products*, provided as Exhibit L to Addendum No. 1 of the Solicitation (1 page).
4. *Clarification on Required Materials*, provided as Exhibit O to Addendum No. 4 of the Solicitation (1 page).
5. *Geotechnical Investigation Report, Proposed Ferndale Preserve Observation Tower / Fishing Pier and Canoe / Kayak Launch, Lake Apopka, Florida*, dated February 21, 2022, prepared by Andreyev Engineering, Inc., for Lake County (61 pages).
6. *U.S. Army Corps of Engineers (ACOE) Letter of Permission for the Lake County / Ferndale Preserve Fishing Pier, Kayak Launch, and Observational Platform / 19220 CR 455, File No. SAJ-2012-01172*, issued November 17, 2023 (67 pages).
7. *Florida Department of Environmental Protection (FDEP) Consolidated Environmental Resource Permit and Sovereignty Submerged Lands Authorization for Ferndale Preserve Fishing Pier, No. 0421812-001-EI*, issued June 17, 2022 (31 pages).

Exhibit – N

**Clarification on Launching, Parking, & Storage**

The logistics of this project are very important to consider when gathering information for submitting a bid package. There will be no ability to load or stage “on-site” as access to the site can only be made over water. Access to the project site must be done only through two separate boat ramps.

Determining which boat ramp will be used is dictated by the purpose of the launch. For instance, one boat ramp will be used for launching a crane barge, but that same boat ramp should not be used for the daily transportation of staff to the project site. Especially if the employees all arrive in separate vehicles and require individual parking spaces.

It may be necessary to travel between both ramps, to and from the project site, daily.

Considerations:

**Parking:**

Storage of trucks and trailers, employee parking, and other construction materials that need temporary rotation in and out of the water will be kept at the McDonald Canal Boat Ramp owned by Lake County as identified in *Figure – 1* of this exhibit.

**Launching:**

The launching of any heavy equipment, barges, rafts/floats, materials loading, etc. must be done from the Montverde Boat ramp identified in *Figure – 2* of this exhibit.

**Security:**

Lake County will not be responsible for the security of any materials, vehicles, trailers, or anything else that will be utilized by the contractor to perform this project. Security will rest solely on the contractor. The McDonald Canal Boat Ramp does have a gate where access to the ramp from the roads are closed nightly. Access to the ramp by water is always available and cannot be prevented at any time. Large vessels cannot be moored at the McDonald Canal Boat Ramp due to the size of a bridge over the canal and there are no locations to moor at the Montverde Boat Ramp.

**Closure to Public:**

It may be necessary to close the Montverde Boat Ramp to the public on occasion to allow for the loading/offloading of materials and equipment. These instances must be kept to a minimum with appropriate advance notice given to the County in order to advertise the closures to the public.

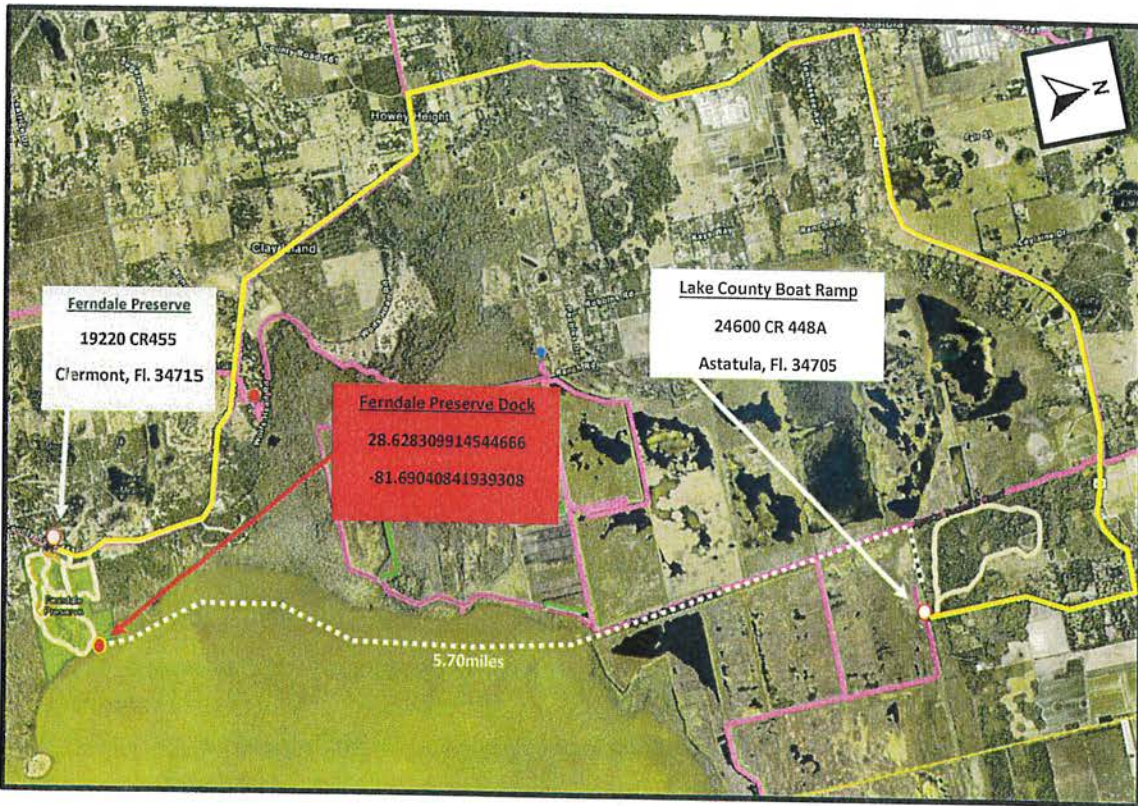

**McDonald Canal Access**

Figure - 1

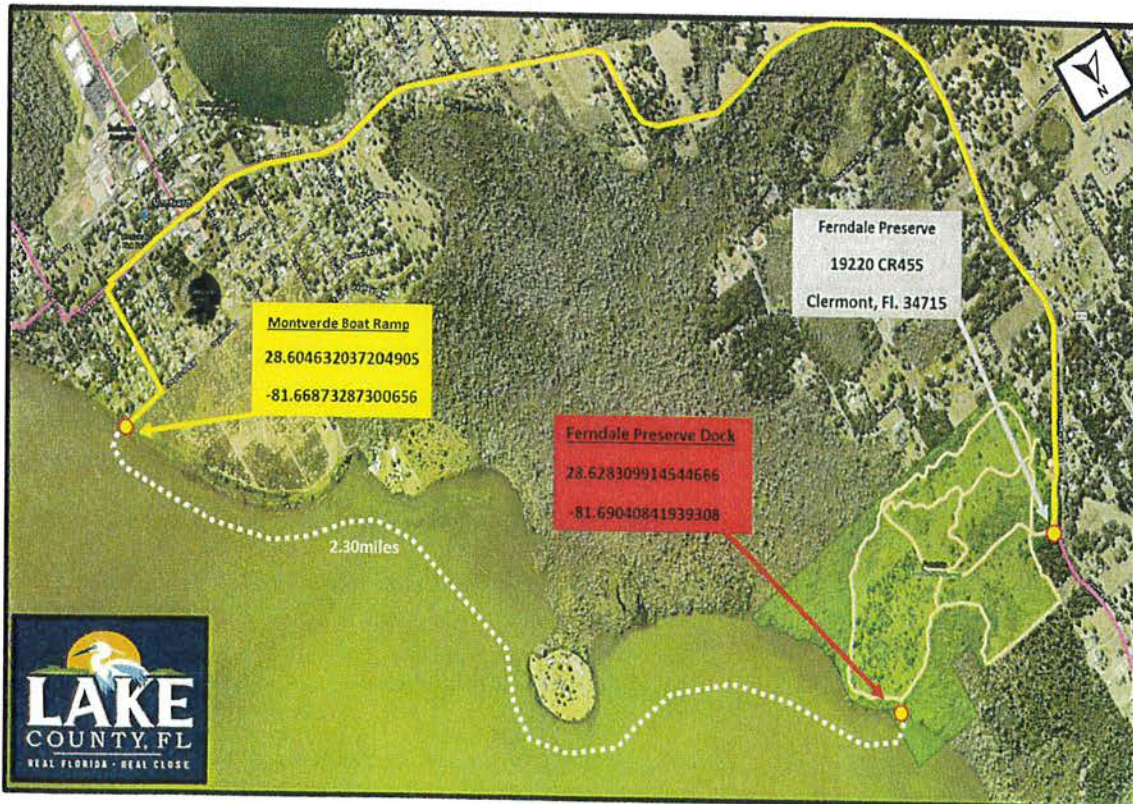

**Montverde Access**

Figure - 2

EXHIBIT E



**CONTRACTOR'S FINAL PAYMENT AFFIDAVIT  
TO BE SUBMITTED WITH ALL FINAL PAYMENT APPLICATIONS**

Before me, the undersigned authority, personally appeared

(Name of affiant) \_\_\_\_\_, who, after being first duly sworn, deposes and says of his or her personal knowledge the following:

1. Affiant is the (Title) \_\_\_\_\_ of  
(Business Name) \_\_\_\_\_  
which does business in the State of Florida, hereinafter called the "Contractor."
2. The Contractor, pursuant to a contract, with the Lake County Board of County Commissioners, hereinafter referred to as the Owner, has furnished or caused to be furnished labor, material, and services for the construction of certain improvements to Real Property as more particularly set forth in said contract(s).
3. This Affidavit is executed by the Contractor accordance with section 713.06 of the Florida Statutes for the purposes of obtaining a final payment in the amount of: \$ \_\_\_\_\_.
4. All work to be performed under the contract has been fully completed, and all lienors under the direct contract have been paid in full, except the following listed lienors

NAME OF LIENOR	AMOUNT DUE
_____	_____
_____	_____

Signed and Delivered on the \_\_\_ day of \_\_\_\_\_, 202\_\_.

BY: \_\_\_\_\_  
Signature of Affiant

\_\_\_\_\_  
Printed Name

STATE OF FLORIDA  
COUNTY OF \_\_\_\_\_

Sworn to (or affirmed) and subscribed before me by means of  physical presence or  online notarization, this \_\_\_ day of \_\_\_\_\_, 20\_\_, by \_\_\_\_\_.

Personally Known OR Produced Identification  
Type of Identification Produced \_\_\_\_\_

\_\_\_\_\_  
(Notary Signature)

(SEAL)



**CONTRACTOR'S PAYMENT TO SUPPLIERS & SUBCONTRACTORS AFFIDAVIT  
TO BE SUBMITTED WITH ALL PAYMENT APPLICATIONS**

Before me, the undersigned authority, personally appeared

(Name of affiant) \_\_\_\_\_, who, after being first duly sworn, deposes and says of his or her personal knowledge the following:

1. Affiant is the (Title) \_\_\_\_\_ of  
(Business Name) \_\_\_\_\_  
which does business in the State of Florida, hereinafter called the "Contractor."
2. The Contractor, pursuant to a contract, with the Lake County Board of County Commissioners, hereinafter referred to as the Owner, has furnished or caused to be furnished labor, material, and services for the construction of certain improvements to Real Property as more particularly set forth in said contract(s).
3. This Affidavit is executed by the Contractor accordance with section 713.06 of the Florida Statutes for the purposes of obtaining a payment in the amount of: \$ \_\_\_\_\_.
4. All work to be performed under this payment application has been fully completed and all suppliers/lienors under this payment application have been paid in full, except the following:

NAME OF SUPPLIER/LIENOR	AMOUNT DUE
_____	_____
_____	_____
_____	_____

Signed and Delivered on the \_\_\_ day of \_\_\_\_\_, 202\_

BY: \_\_\_\_\_  
Signature of Affiant

\_\_\_\_\_  
Printed Name

STATE OF FLORIDA  
COUNTY OF \_\_\_\_\_

Sworn to (or affirmed) and subscribed before me by means of  physical presence or  online notarization, this \_\_\_ day of \_\_\_\_\_, 20\_\_, by \_\_\_\_\_.

Personally Known OR Produced Identification  
Type of Identification Produced \_\_\_\_\_

\_\_\_\_\_  
(Notary Signature)

(SEAL)

**PERFORMANCE/PAYMENT BOND**

Award Recommended Vendor (ARV) shall execute and deliver to County a Performance and Payment Bond in an amount representing 100% of Contract price. The County’s Performance and Payment Bond Form shall be the only acceptable form. Completed form must be delivered to County within fifteen (15) calendar days after formal notice of award. Failure to deliver the Performance and Payment Bond as directed will result in ARV being declared in default of contractual terms and conditions. ARV shall surrender the associated proposal bond (if any). No bid submissions will be accepted from ARV for the following twelve (12) month period.

- A. Bonds shall be written through Surety Insurers (Surety) listed on Sunbiz.org as surety, with the management and financial strength qualifications according to the latest edition of Best's Insurance Guide, published by A.M. Best Company, Oldwick, New Jersey:

<u>Bond Amount</u>	<u>Best Rating</u>
500,001 to 1,500,000	B V
1,500,001 to 2,500,000	A VI
2,500,001 to 5,000,000	A VII
5,000,001 to 10,000,000	A VIII
Over 10,000,000	A IX

- B. Contracts under \$500,000, bond provisions of Section 287.0935, Florida Statutes apply.
- C. Contracts over \$500,000, provisions of Section B apply plus Surety must be on the Treasury List for the last three consecutive years or hold a valid Certificate of Authority of at least 1.5 million dollars and be on the current Treasury List. Surety must be in the current [Surety Bonds - List of Certified Companies \(treasury.gov\)](#) published by US Department of the Treasury. Bond amount must not exceed underwriting limitations shown in the List.
- D. Surety Bonds guaranteed through U.S. Government Small Business Administration or Contractors Training and Development Inc. will be acceptable.
- E. An irrevocable letter of credit or a cash bond in the form of a certified cashier’s check written to the Board of County Commissioners will be acceptable. Interest will accrue to County if funds are held by County.
- F. The attorney-in-fact or other officer signing a contract bond for a Surety must include a certified copy of power of attorney authorizing the officer to do so. Contract bond must be counter signed by Surety's resident Florida agent.

**AWARD RECOMMENDED VENDOR INSTRUCTIONS**

Upon award, completed original County approved Performance/Payment bond forms shall be submitted to Lake County Procurement Services for bond recording. Bond(s) will be acceptable to County if the following exists:

- A. Surety is licensed to do business in the State of Florida;
- B. Surety holds a Certificate of Authority authorizing it to write surety bonds in this State;
- C. Surety has twice the minimum surplus and capital requirements required by the Florida Insurance Code at the time the invitation to bid is issued;
- D. Surety is otherwise in compliance with the Florida Insurance Code;
- E. Surety has a current rating of A or A- as reported in the most current Best Key Rating Guide, published by A.M. Best Company, Inc., if the bid exceeds \$500,000.; and
- F. Surety holds a currently valid Certificate of Authority issued by the United States Department of Treasury under 31 U.S.C. Section 9304.

Performance/Payment Bond recording fee is ten dollars (\$10.00) for first page and eight dollars and fifty cents (\$8.50) for each additional page. Submit a check made payable to Gary J. Cooney, Clerk of the Court.

PERFORMANCE BOND

BOND NO. \_\_\_\_\_

**KNOW ALL MEN BY THESE PRESENTS:** that We,

Contractor \_\_\_\_\_  
Contractor Address \_\_\_\_\_  
Contractor Address 2 \_\_\_\_\_  
Contractor Telephone \_\_\_\_\_

(hereinafter called the "Principal"), whose principal business address and telephone number is as stated above; and

Surety \_\_\_\_\_  
Surety Address \_\_\_\_\_  
Surety Address 2 \_\_\_\_\_  
Surety Phone \_\_\_\_\_

(hereinafter called the "Surety"), whose principal address and telephone number is as stated above, a surety insurer chartered and existing under the laws of the State of \_\_\_\_\_ and authorized to do business in the State of Florida; are held and firmly bound unto Lake County Board of County Commissioners, Lake County, Florida (hereinafter called the "Obligee"), whose principal address is P.O. Box 7800, Tavares, Florida 32778, and whose principal telephone number is (352) 343-9800, in the sum of

\_\_\_\_\_ (\$ \_\_\_\_\_) for payment of which we bind ourselves, our heirs, our legal representatives, our successors and our assignees, jointly and severally.

**WHEREAS**, Principal has entered into a contract with Obligee for \_\_\_\_\_ Contract No. \_\_\_\_\_ in accordance with drawings and specifications, which contract is incorporated herein by reference and made a part hereof, and is referred to as the Contract.

**NOW THEREFORE, THE CONDITION OF THIS BOND** are such that if Principal:

1. Fully, promptly, and faithfully performs the Contract at the times and in the manner prescribed in the Contract, including all obligations imposed by the Contract documents, specifications, and changes orders;
2. Pays Obligee any and all losses, damages, costs and attorneys' fees, including appellate proceedings, that Obligee sustains because of any default by Principal under the Contract, including, but not limited to, all delay damages, whether liquidated or actual, incurred by Obligee;
3. Performs the guarantee of all work and materials furnished under the Contract for the time specified in the Contract; and
4. Promptly make all payments to all persons defined in Section 713.01, Florida Statutes, as amended, whose claims derive directly or indirectly from the prosecution of the work provided for in the Contract;

then this bond shall be void; otherwise it remains in full force and effect.



BOND NO. \_\_\_\_\_

The Surety, for value received, hereby stipulates and agrees that no changes, extensions of time, alterations or additions to the terms of the Contract or other work to be performed hereunder, or the specifications referred to therein shall in any way affect Surety's obligation under this bond, and it does hereby waive notice of any such changes, extensions of time, alterations or additions to the terms of the Contract or to work or to the specifications.

This instrument shall be construed in all respects as a statutory bond. It is expressly understood the time provisions and statute of limitations under Section 255.05, Florida Statutes, as amended, shall apply to this bond.

By execution of this bond, the Surety acknowledges that it has read the Surety qualifications and obligations imposed by the Contract and hereby satisfies those conditions.

The parties agree that this public performance bond and any claims instituted under this bond shall be governed by the laws, rules and regulations of the State of Florida and venue shall be in a court of competent jurisdiction in and for Lake County, Florida.

**IN WITNESS WHEREOF**, the above bounded parties have executed this instrument on the day and year below mentioned, the name of each party being affixed and these presents duly signed by its/their undersigned representative(s), pursuant to authority of its governing body.

Signed, sealed and delivered  
in the presence of:

**Contractor, as PRINCIPAL:**

Company: \_\_\_\_\_

By: \_\_\_\_\_  
(Authorized Signature)

Printed Name: \_\_\_\_\_

Title: \_\_\_\_\_

Date: \_\_\_\_\_

\_\_\_\_\_  
#1 Witness as to Principal

\_\_\_\_\_  
#2 Witness as to Principal

STATE OF FLORIDA  
COUNTY OF \_\_\_\_\_

The foregoing instrument was acknowledged before me by means of  physical presence or  online notarization, this \_\_\_\_ day of \_\_\_\_\_, 20\_\_\_\_, by \_\_\_\_\_ as \_\_\_\_\_ for \_\_\_\_\_.

Personally Known OR Produced Identification  
Type of Identification Produced \_\_\_\_\_

\_\_\_\_\_  
(Notary Signature)

(SEAL)

BOND NO. \_\_\_\_\_

**SURETY:**

Company: \_\_\_\_\_

By: \_\_\_\_\_  
(Authorized Signature)

Printed Name: \_\_\_\_\_

Title: \_\_\_\_\_

Date: \_\_\_\_\_

\_\_\_\_\_  
#1 Witness as to Surety

\_\_\_\_\_  
#2 Witness as to Surety

**OR BY ATTORNEY IN FACT (POWER OF ATTORNEY MUST BE ATTACHED)**

\_\_\_\_\_  
#1 Witness as Attorney In Fact

\_\_\_\_\_  
#2 Witness as Attorney In Fact

By: \_\_\_\_\_  
(As Attorney In Fact)

Printed Name: \_\_\_\_\_

Date: \_\_\_\_\_

Address: \_\_\_\_\_

\_\_\_\_\_

\_\_\_\_\_

Phone: \_\_\_\_\_

STATE OF FLORIDA  
COUNTY OF \_\_\_\_\_

The foregoing instrument was acknowledged before me by means of  physical presence or  online  
notarization, this \_\_\_\_ day of \_\_\_\_\_, 20\_\_\_\_, by \_\_\_\_\_ as  
\_\_\_\_\_ for \_\_\_\_\_.

Personally Known OR Produced Identification  
Type of Identification Produced \_\_\_\_\_

\_\_\_\_\_  
(Notary Signature)

(SEAL)

PAYMENT BOND

BOND NO. \_\_\_\_\_

**KNOW ALL MEN BY THESE PRESENTS:** that We,

Contractor \_\_\_\_\_  
Contractor Address \_\_\_\_\_  
Contractor Address 2 \_\_\_\_\_  
Contractor Telephone \_\_\_\_\_

(hereinafter called the "Principal"), whose principal business address and telephone number is as stated above; and

Surety \_\_\_\_\_  
Surety Address \_\_\_\_\_  
Surety Address 2 \_\_\_\_\_  
Surety Phone \_\_\_\_\_

(hereinafter called the "Surety"), whose principal address and telephone number is as stated above, a surety insurer chartered and existing under the laws of the State of \_\_\_\_\_ and authorized to do business in the State of Florida; are held and firmly bound unto Lake County Board of County Commissioners, Lake County, Florida (hereinafter called the "Obligee"), whose principal address is P.O. Box 7800, Tavares, Florida 32778, and whose principal telephone number is (352) 343-9800, in the sum of

\_\_\_\_\_ (\$ \_\_\_\_\_)

for payment of which we bind ourselves, our heirs, our legal representatives, our successors and our assignees, jointly and severally.

**WHEREAS,** Principal and Obligee as Owner have reached a mutual agreement for \_\_\_\_\_ (hereinafter referred to as the "Contract") which conditions and provisions as are further described in the aforementioned Contract, which said Contract being made a part of this Bond by this reference for the purpose of perfecting this Bond.

**NOW THEREFORE, THE CONDITIONS OF THIS BOND** are such that if Principal:

1. Shall promptly make payments to all claimants as defined in Section 255.05(1), Florida Statutes, as amended, supplying the Principal with labor, materials or supplies, as used directly or indirectly by the Principal in the prosecution of the work provided for in the Contract; and
2. Shall pay the Obligee for all losses, damages, expenses, costs and attorneys' fees, including those resulting from appellate proceedings, that the Obligee sustains because of a default by the Principal in contravention to the Contract in regard to payment for such labor, materials, or supplies furnished to the Principal;

then this bond shall be void; otherwise this Bond remains in full force and effect.

BOND NO. \_\_\_\_\_

**BE IT FURTHER KNOWN AND AGREED TO BY THE PARTIES THAT:**

1. Any changes in or under the Contract and compliance or noncompliance with any formalities connected with the said Contract or alterations which may be made in the terms of the said Contract, or in the work to be done under it, or the giving by the Obligee of any extension of time for the performance of the said Contract, or any other forbearance on the part of the Obligee or Principal to the other, shall not in any way release the Principal and the Surety, or either of them, their heirs, personal representatives, successors or assigns from liability hereunder, notice to the Surety of any such changes, alterations, extensions or forbearance being hereby waived.
2. Certain claimants seeking the protection of this Bond must timely comply with the strict requirements set forth in Section 255.05, Florida Statutes, as amended, and as otherwise provided by law.
3. The Provisions of this bond are subject to the limitations of Section 255.05(2), Florida Statutes, as amended.

By execution of this bond, the Surety acknowledges that it has read the Surety qualifications and obligations imposed by the Contract and hereby satisfies those conditions.

The parties agree that this public bond and any claims instituted under this bond shall be governed by the laws, rules and regulations of the State of Florida and venue shall be in a court of competent jurisdiction in and for Lake County, Florida.

**IN WITNESS WHEREOF**, the above bounded parties have executed this instrument on the day and year below mentioned, the name of each party being affixed and these presents duly signed by its/their undersigned representative(s), pursuant to authority of its governing body.

Signed, sealed and delivered  
in the presence of:

**Contractor, as PRINCIPAL:**

Company: \_\_\_\_\_

By: \_\_\_\_\_  
(Authorized Signature)

Printed Name: \_\_\_\_\_

Title: \_\_\_\_\_

Date: \_\_\_\_\_

\_\_\_\_\_  
#1 Witness as to Principal

\_\_\_\_\_  
#2 Witness as to Principal

STATE OF FLORIDA  
COUNTY OF \_\_\_\_\_

The foregoing instrument was acknowledged before me by means of  physical presence or  online notarization, this \_\_\_\_ day of \_\_\_\_\_, 20\_\_\_\_, by \_\_\_\_\_ as \_\_\_\_\_ for \_\_\_\_\_.

Personally Known OR Produced Identification  
Type of Identification Produced \_\_\_\_\_

\_\_\_\_\_  
(Notary Signature)

(SEAL)

**EXHIBIT G**

**CERTIFICATION REGARDING LOBBYING**

24-925

**APPENDIX A, 44 C.F.R. PART 18 -CERTIFICATION REGARDING LOBBYING**

Certification for contracts, grants, loans, and cooperative agreements (To be submitted with each bid or offer exceeding \$100,000).

The undersigned [Contractor] certifies, to the best of his or her knowledge, that:

1. No Federal appropriated funds have been paid or will be paid, by or on behalf of the undersigned, to any person for influencing or attempting to influence an officer or employee of an agency, a Member of Congress, an officer or employee of Congress, or an employee of a Member of Congress in connection with the awarding of any Federal contract, the making of any Federal grant, the making of any Federal loan, the entering into of any cooperative agreement, and the extension, continuation, renewal, amendment, or modification of any Federal contract, grant, loan, or cooperative agreement.
2. If any funds other than Federal appropriated funds have been paid or will be paid to any person for influencing or attempting to influence an officer or employee of any agency, a Member of Congress, an officer or employee of Congress, or an employee of a Member of Congress in connection with this Federal contract, grant, loan, or cooperative agreement, the undersigned shall complete and submit Standard Form LLL, "Disclosure Form to Report Lobbying," in accordance with its instructions.
3. The undersigned shall require that the language of this certification be included in the award documents for all subawards at all tiers (including subcontracts, subgrants, and contracts under grants, loans, and cooperative agreements) and that all subrecipients shall certify and disclose accordingly.

This certification is a material representation of fact upon which reliance was placed when this transaction was made or entered into. Submission of this certification is a prerequisite for making or entering into this transaction imposed by 31, U.S.C. § 1352 (as amended by the Lobbying Disclosure Act of 1995). Any person who fails to file the required certification shall be subject to a civil penalty of not less than \$10,000 and not more than \$100,000 for each such failure. The Contractor below certifies or affirms the truthfulness and accuracy of each statement of its certification and disclosure, if any. In addition, the Contractor understands and agrees that the provisions of 31 U.S.C. § 3801 et seq., apply to this certification and disclosure, if any.

**COMPANY NAME:** \_\_\_\_\_

**ADDRESS:** \_\_\_\_\_

**CITY:** \_\_\_\_\_

**STATE & Zip Code:** \_\_\_\_\_

**COMPANY'S AUTHORIZED OFFICAL:**

**SIGNATURE:** \_\_\_\_\_

**Printed Name:** \_\_\_\_\_

**Title:** \_\_\_\_\_

**Date:** \_\_\_\_\_