

BOUNDARY SURVEY

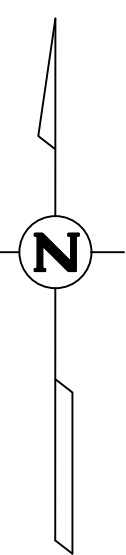
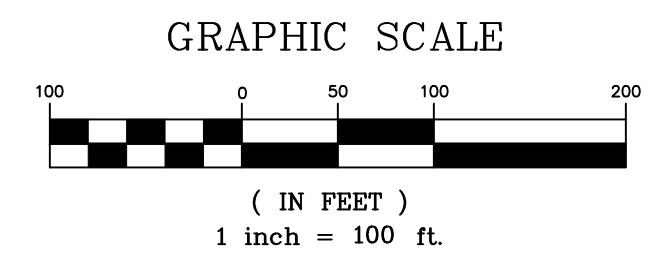

Wetland Line Table

Line #	Length	Direction
L1	91.66'	S16°46'21"W
L2	68.90'	S11°53'39"W
L3	86.26'	S15°40'41"W
L4	64.77'	S25°26'09"W
L5	47.72'	S54°22'55"W
L6	54.36'	S74°36'31"W
L7	82.06'	N78°18'19"W

NOT INCLUDED SHANNON/TAMM, LLC ORB 5272, PG 660 ALT KEY 1028701
SEE PREVIOUS SURVEY BY BESH DATED 4-19-2016
SEE ALSO PREVIOUS SURVEY BY WILE GILLESPIE DATED 1937

LAKE MARQUIS ESTATES
PB 29, PG 98

BARCLAY'S ADDITION
TO LANE PARK
(SUMTER COUNTY, FLORIDA)

SHEET 2 OF 2

BOUNDARY SURVEY
SECTION 6, TOWNSHIP 20 SOUTH, RANGE 26 EAST
LAKE COUNTY, FLORIDA.

CLIENT	Lake County Attorney's Office
JOB NO.	043862.056
ACAD FILE	43862.056 Lane Park Commons BDY Update
DATE	8/18/2021 CHECKED BY: JTM
DRAWN BY:	SMB FLD. BOOK: 06-01-18/3
REVISIONS	DATE

ALTERNATE KEYS 1028689,
1114501 & 3022548
TAVARES, FLORIDA

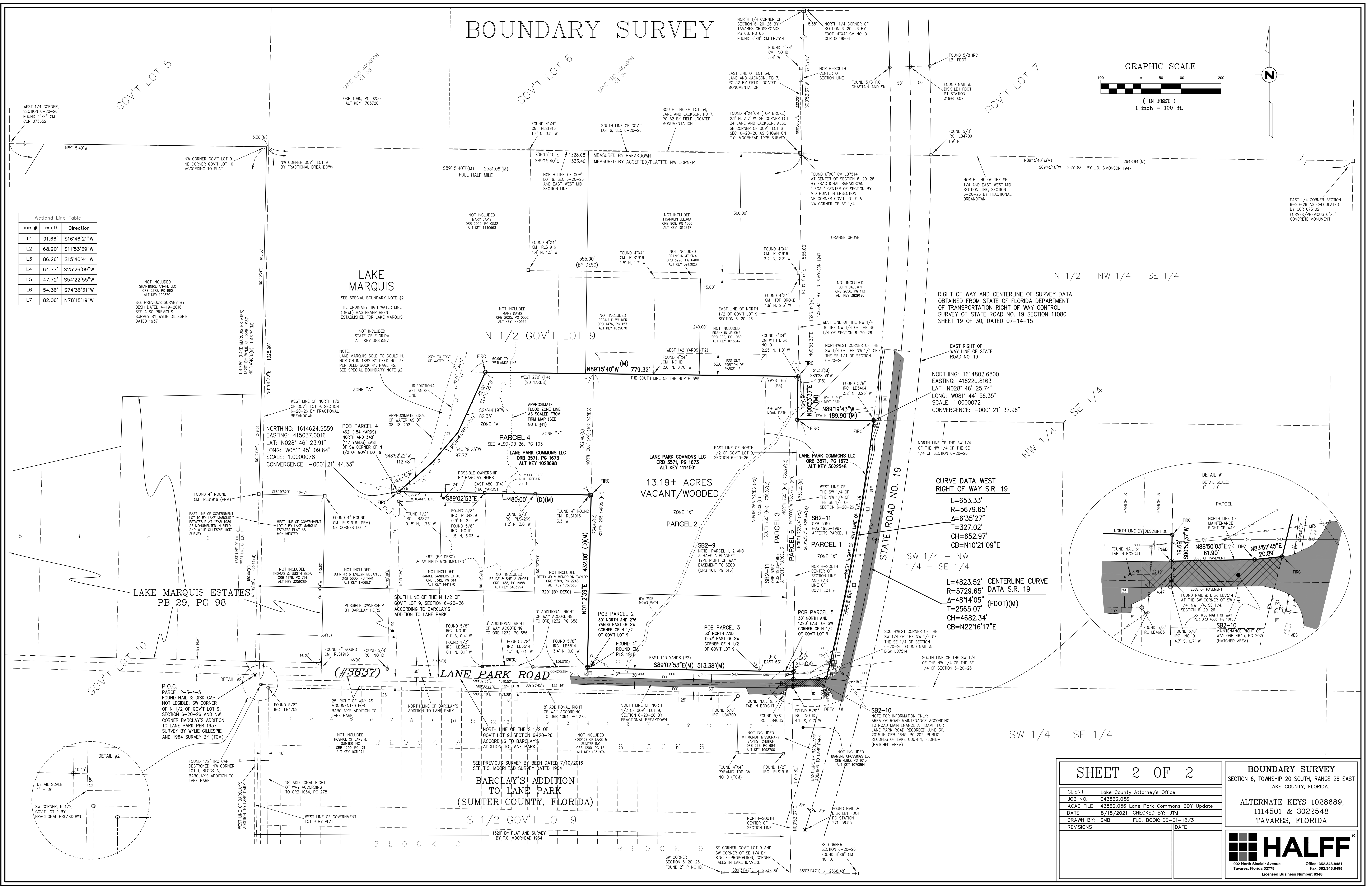

CURVE DATA WEST
RIGHT OF WAY S.R. 19
L=653.33'
R=5679.65'
Δ=6°35'27"
T=327.02'
CH=652.97'
CB=N102°10'9"E

CURVE DATA CENTERLINE
DATA S.R. 19
L=4823.52'
R=5729.65'
Δ=48°14'05"
T=2565.07'
CH=4682.34'
CB=N22°16'17"E

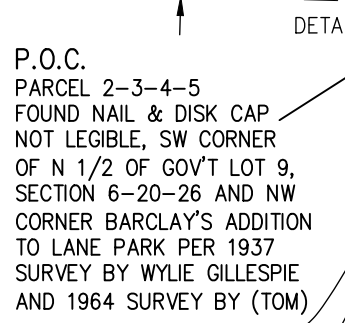
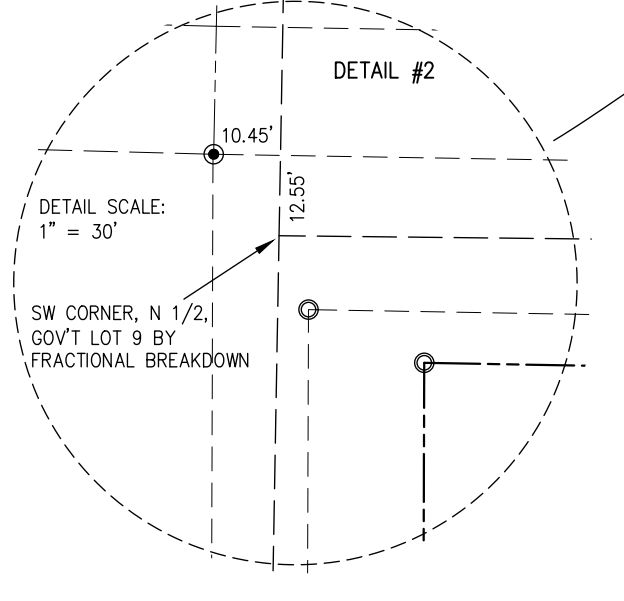
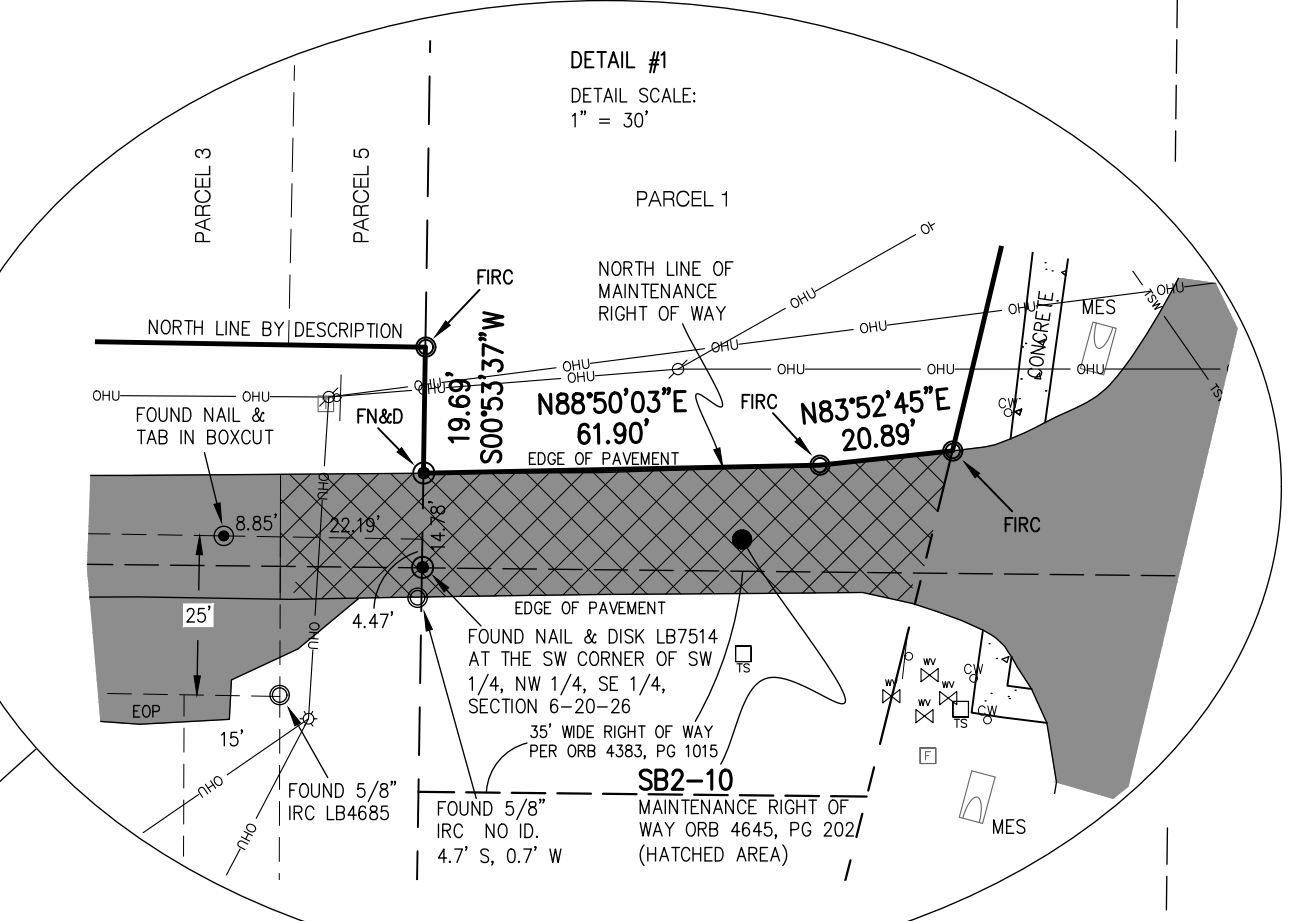

P.O.C. PARCEL 2-3-4-5
FOUND NAIL & DISK CAP
NOT LEGIBLE, SW CORNER
OF N 1/2 OF GOV'T LOT 9,
SECTION 6-20-26 AND NW
CORNER BARCLAY'S ADDITION
TO LANE PARK PER 1937
SURVEY BY WILE GILLESPIE
AND 1964 SURVEY BY (TOM)

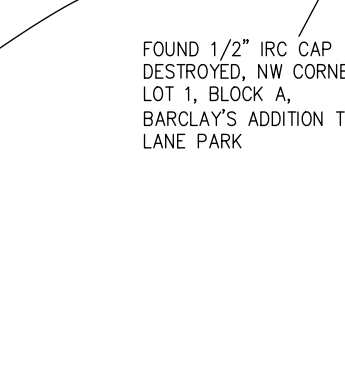

WEST LINE OF BARCLAY'S
ADDITION TO LANE PARK



WEST LINE OF GOVERNMENT
LOT 9 BY PLAT



18' ADDITIONAL RIGHT
OF WAY ACCORDING
TO ORB 1064, PG 378

1320' BY PLAT AND SURVEY
BY T.O. MOORHEAD 1964

SW CORNER GOV'T LOT 9 AND
SW CORNER OF SE 1/4 BY
SINGLE-PROPORTION, CORNER
FALLS IN LAKE DAMERE
FOUND 2" IP NO ID
S89°31'47"E 2537.06'

SE CORNER SECTION 6-20-26
FOUND 6"x6" CM
NO ID.

SE CORNER SECTION 6-20-26
FOUND 6"x6" CM
NO ID.

SE CORNER SECTION 6-20-26
FOUND 6"x6" CM
NO ID.

SE CORNER SECTION 6-20-26
FOUND 6"x6" CM
NO ID.

SE CORNER SECTION 6-20-26
FOUND 6"x6" CM
NO ID.

SE CORNER SECTION 6-20-26
FOUND 6"x6" CM
NO ID.

SE CORNER SECTION 6-20-26
FOUND 6"x6" CM
NO ID.

SE CORNER SECTION 6-20-26
FOUND 6"x6" CM
NO ID.

SE CORNER SECTION 6-20-26
FOUND 6"x6" CM
NO ID.

SE CORNER SECTION 6-20-26
FOUND 6"x6" CM
NO ID.

SE CORNER SECTION 6-20-26
FOUND 6"x6" CM
NO ID.

SE CORNER SECTION 6-20-26
FOUND 6"x6" CM
NO ID.

SE CORNER SECTION 6-20-26
FOUND 6"x6" CM
NO ID.

SE CORNER SECTION 6-20-26
FOUND 6"x6" CM
NO ID.

SE CORNER SECTION 6-20-26
FOUND 6"x6" CM
NO ID.

SE CORNER SECTION 6-20-26
FOUND 6"x6" CM
NO ID.

SE CORNER SECTION 6-20-26
FOUND 6"x6" CM
NO ID.

SE CORNER SECTION 6-20-26
FOUND 6"x6" CM
NO ID.

SE CORNER SECTION 6-20-26
FOUND 6"x6" CM
NO ID.

SE CORNER SECTION 6-20-26
FOUND 6"x6" CM
NO ID.

SE CORNER SECTION 6-20-26
FOUND 6"x6" CM
NO ID.

SE CORNER SECTION 6-20-26
FOUND 6"x6" CM
NO ID.

SE CORNER SECTION 6-20-26
FOUND 6"x6" CM
NO ID.

SE CORNER SECTION 6-20-26
FOUND 6"x6" CM
NO ID.

SE CORNER SECTION 6-20-26
FOUND 6"x6" CM
NO ID.

SE CORNER SECTION 6-20-26
FOUND 6"x6" CM
NO ID.

SE CORNER SECTION 6-20-26
FOUND 6"x6" CM
NO ID.

SE CORNER SECTION 6-20-26
FOUND 6"x6" CM
NO ID.

SE CORNER SECTION 6-20-26
FOUND 6"x6" CM
NO ID.

SE CORNER SECTION 6-20-26
FOUND 6"x6" CM
NO ID.

SE CORNER SECTION 6-20-26
FOUND 6"x6" CM
NO ID.

SE CORNER SECTION 6-20-26
FOUND 6"x6" CM
NO ID.

SE CORNER SECTION 6-20-26
FOUND 6"x6" CM
NO ID.

SE CORNER SECTION 6-20-26
FOUND 6"x6" CM
NO ID.

SE CORNER SECTION 6-20-26
FOUND 6"x6" CM
NO ID.

SE CORNER SECTION 6-20-26
FOUND 6"x6" CM
NO ID.

SE CORNER SECTION 6-20-26
FOUND 6"x6" CM
NO ID.

SE CORNER SECTION 6-20-26
FOUND 6"x6" CM
NO ID.

SE CORNER SECTION 6-20-26
FOUND 6"x6" CM
NO ID.

SE CORNER SECTION 6-20-26
FOUND 6"x6" CM
NO ID.

SE CORNER SECTION 6-20-26
FOUND 6"x6" CM
NO ID.

SE CORNER SECTION 6-20-26
FOUND 6"x6" CM
NO ID.

SE CORNER SECTION 6-20-26
FOUND 6"x6" CM
NO ID.

SE CORNER SECTION 6-20-26
FOUND 6"x6" CM
NO ID.

SE CORNER SECTION 6-20-26
FOUND 6"x6" CM
NO ID.

SE CORNER SECTION 6-20-26
FOUND 6"x6" CM
NO ID.

SE CORNER SECTION 6-20-26
FOUND 6"x6" CM
NO ID.

SE CORNER SECTION 6-20-26
FOUND 6"x6" CM
NO ID.

SE CORNER SECTION 6-20-26
FOUND 6"x6" CM
NO ID.

SE CORNER SECTION 6-20-26
FOUND 6"x6" CM
NO ID.

SE CORNER SECTION 6-20-26
FOUND 6"x6" CM
NO ID.

SE CORNER SECTION 6-20-26
FOUND 6"x6" CM
NO ID.

SE CORNER SECTION 6-20-26
FOUND 6"x6" CM
NO ID.

SE CORNER SECTION 6-20-26
FOUND 6"x6" CM
NO ID.

SE CORNER SECTION 6-20-26
FOUND 6"x6" CM
NO ID.

SE CORNER SECTION 6-20-26
FOUND 6"x6" CM
NO ID.

SE CORNER SECTION 6-20-26
FOUND 6"x6" CM
NO ID.

SE CORNER SECTION 6-20-26
FOUND 6"x6" CM
NO ID.

SE CORNER SECTION 6-20-26
FOUND 6"x6" CM
NO ID.

SE CORNER SECTION 6-20-26
FOUND 6"x6" CM
NO ID.

SE CORNER SECTION 6-20-26
FOUND 6"x6" CM
NO ID.

SE CORNER SECTION 6-20-26
FOUND 6"x6" CM
NO ID.

SE CORNER SECTION 6-20-26
FOUND 6"x6" CM
NO ID.

SE CORNER SECTION 6-20-26
FOUND 6"x6" CM
NO ID.

SE CORNER SECTION 6-20-26
FOUND 6"x6" CM
NO ID.

SE CORNER SECTION 6-20-26
FOUND 6"x6" CM
NO ID.

SE CORNER SECTION 6-20-26
FOUND 6"x6" CM
NO ID.

SE CORNER SECTION 6-20-26
FOUND 6"x6" CM
NO ID.

SE CORNER SECTION 6-20-26
FOUND 6"x6" CM
NO ID.

SE CORNER SECTION 6-20-26
FOUND 6"x6" CM
NO ID.

SE CORNER SECTION 6-20-26
FOUND 6"x6" CM
NO ID.

SE CORNER SECTION 6-20-26
FOUND 6"x6" CM
NO ID.

SE CORNER SECTION 6-20-26
FOUND 6"x6" CM
NO ID.

SE CORNER SECTION 6-20-26
FOUND 6"x6" CM
NO ID.

SE CORNER SECTION 6-20-26
FOUND 6"x6" CM
NO ID.

SE CORNER SECTION 6-20-26
FOUND 6"x6" CM
NO ID.

SE CORNER SECTION 6-20-26
FOUND 6"x6" CM
NO ID.

SE CORNER SECTION 6-20-26
FOUND 6"x6" CM
NO ID.

SE CORNER SECTION 6-20-26
FOUND 6"x6" CM
NO ID.

SE CORNER SECTION 6-20-26
FOUND 6"x6" CM
NO ID.

SE CORNER SECTION 6-20-26
FOUND 6"x6" CM
NO ID.

SE CORNER SECTION 6-20-26
FOUND 6"x6" CM
NO ID.

SE CORNER SECTION 6-20-26
FOUND 6"x6" CM
NO ID.

SE CORNER SECTION 6-20-26
FOUND 6"x6" CM
NO ID.

SE CORNER SECTION 6-20-26
FOUND 6"x6" CM
NO ID.

SE CORNER SECTION 6-20-26
FOUND 6"x6" CM
NO ID.

SE CORNER SECTION 6-20-26
FOUND 6"x6" CM
NO ID.

SE CORNER SECTION 6-20-26
FOUND 6"x6" CM
NO ID.

SE CORNER SECTION 6-20-26
FOUND 6"x6" CM
NO ID.

SE CORNER SECTION 6-20-26
FOUND 6"x6" CM
NO ID.

SE CORNER SECTION 6-20-26
FOUND 6"x6" CM
NO ID.

SE CORNER SECTION 6-20-26
FOUND 6"x6" CM
NO ID.

SE CORNER SECTION 6-20-26
FOUND 6"x6" CM
NO ID.

SE CORNER SECTION 6-20-26
FOUND 6"x6" CM
NO ID.

SE CORNER SECTION 6-20-26
FOUND 6"x6" CM
NO ID.

SE CORNER SECTION 6-20-26
FOUND 6"x6" CM
NO ID.

SE CORNER SECTION 6-20-26
FOUND 6"x6" CM
NO ID.

SE CORNER SECTION 6-20-26
FOUND 6"x6" CM
NO ID.

SE CORNER SECTION 6-20-26
FOUND 6"x6" CM
NO ID.

SE CORNER SECTION 6-20-26
FOUND 6"x6" CM
NO ID.

SE CORNER SECTION 6-20-26
FOUND 6"x6" CM
NO ID.

SE CORNER SECTION 6-20-26
FOUND 6"x6" CM
NO ID.

SE CORNER SECTION 6-20-26
FOUND 6"x6" CM
NO ID.

SE CORNER SECTION 6-20-26
FOUND 6"x6" CM
NO ID.

SE CORNER SECTION 6-20-26
FOUND 6"x6" CM
NO ID.

SE CORNER SECTION 6-20-26
FOUND 6"x6" CM
NO ID.

SE CORNER SECTION 6-20-26
FOUND 6"x6" CM
NO ID.

SE CORNER SECTION 6-20-26
FOUND 6"x6" CM
NO ID.

SE CORNER SECTION 6-20-26
FOUND 6"x6" CM
NO ID.

SE CORNER SECTION 6-20-26
FOUND 6"x6" CM
NO ID.

SE CORNER SECTION 6-20-26
FOUND 6"x6" CM
NO ID.

SE CORNER SECTION 6-20-26
FOUND 6"x6" CM
NO ID.

SE CORNER SECTION 6-20-26
FOUND 6"x6" CM
NO ID.

SE CORNER SECTION 6-20-26
FOUND 6"x6" CM
NO ID.

SE CORNER SECTION 6-20-26
FOUND 6"x6" CM
NO ID.

SE CORNER SECTION 6-20-26
FOUND 6"x6" CM
NO ID.

SE CORNER SECTION 6-20-26
FOUND 6"x6" CM
NO ID.

SE CORNER SECTION 6-20-26
FOUND 6"x6" CM
NO ID.

SE CORNER SECTION 6-20-26
FOUND 6"x6" CM
NO ID.

SE CORNER SECTION 6-20-26
FOUND 6"x6" CM
NO ID.

SE CORNER SECTION 6-20-26
FOUND 6"x6" CM
NO ID.

SE CORNER SECTION 6-20-26
FOUND 6"x6" CM
NO ID.

SE CORNER SECTION 6-20-26
FOUND 6"x6" CM
NO ID.

SE CORNER SECTION 6-20-26
FOUND 6"x6" CM
NO ID.

SE CORNER SECTION 6-20-26
FOUND 6"x6" CM
NO ID.

SE CORNER SECTION 6-20-26
FOUND 6"x6" CM
NO ID.

SE CORNER SECTION 6-20-26
FOUND 6"x6" CM
NO ID.

SE CORNER SECTION 6-20-26
FOUND 6"x6" CM
NO ID.

SE CORNER SECTION 6-20-26
FOUND 6"x6" CM
NO ID.

SE CORNER SECTION 6-20-26
FOUND 6"x6" CM
NO ID.

SE CORNER SECTION 6-20-26
FOUND 6"x6" CM
NO ID.

SE CORNER SECTION 6-20-26
FOUND 6"x6" CM
NO ID.

SE CORNER SECTION 6-20-26
FOUND 6"x6" CM
NO ID.

SE CORNER SECTION 6-20-26
FOUND 6"x6" CM
NO ID.

SE CORNER SECTION 6-20-26
FOUND 6"x6" CM
NO ID.

SE CORNER SECTION 6-20-26
FOUND 6"x6" CM
NO ID.

SE CORNER SECTION 6-20-26
FOUND 6"x6" CM
NO ID.

SE CORNER SECTION 6-20-26
FOUND 6"x6" CM
NO ID.

SE CORNER SECTION 6-20-26
FOUND 6"x6" CM
NO ID.

SE CORNER SECTION 6-20-26
FOUND 6"x6" CM
NO ID.

SE CORNER SECTION 6-20-26
FOUND 6"x6" CM
NO ID.

SE CORNER SECTION 6-20-26
FOUND 6"x6" CM
NO ID.

SE CORNER SECTION 6-20-26
FOUND 6"x6" CM
NO ID.

SE CORNER SECTION 6-20-26
FOUND 6"x6" CM
NO ID.

SE CORNER SECTION 6-20-26
FOUND 6"x6" CM
NO ID.

SE CORNER SECTION 6-20-26
FOUND 6"x6" CM
NO ID.

SE CORNER SECTION 6-20-26
FOUND 6"x6" CM
NO ID.

SE CORNER SECTION 6-20-26
FOUND 6"x6" CM
NO ID.

SE CORNER SECTION 6-20-26
FOUND 6"x6" CM
NO ID.

SE CORNER SECTION