

**BOARD OF COUNTY COMMISSIONERS
LAKE COUNTY, FLORIDA
OFFICE OF THE COUNTY MANAGER
AGENDA ITEM COVER SHEET**

DATE: 06/23/2016

TO: David Heath, County Manager

THRU:

Lori Koontz, Road Ops Division Manager
Jim Stivender, Public Works Director

MEETING DATE: 07/12/2016

ITEM TYPE: Consent Item

ITEM ID: 2983

BY: Deb Marchese, Construction Program Specialist

SUBJECT: North Hancock Road Extension Phase IIIA and IIIB Project No. 2014-11

RECOMMENDATION/REQUIRED ACTION:

Request approval for the Chairman to execute Change Order #3 to the North Hancock Road Extension and Widening Phase IIIA and IIIB Project No. 2014-11, Bid No. 14-0030, to Pospiech Contracting. Change Order #3 is for modifications of various items to include: pedestrian safety, concrete ditch paving, milling and resurfacing, paving and maintenance of traffic, concrete gravity wall and guiderail, trail ramps, full depth construction, survey, sidewalk, stormwater pipe and structures, driveway milling and resurfacing, and add sixty (60) days to the contract completion time. The net total cost of the work is \$39,957.31 to be funded by Road Impact Fee South Benefit District Fund. Commission District 2

BACKGROUND SUMMARY:

On October 28, 2014, the Board of County Commissioners awarded the construction of the North Hancock Road Extension and Widening Phase IIIA and IIIB Project No. 2014-11 to Pospiech Contracting, Inc. in the amount of \$8,430,070.44. The project consists of constructing and widening North Hancock Road to a four-lane urban designed roadway with curb and gutter, bike lanes, sidewalks, and multi-use trail. The project extends from CR-50 and runs north to the proposed new turnpike interchange.

Contractor change order summary: Change Order #1 in the amount of \$18,390.14 is within the County Manager's approval authority and included the following: delete two gravity walls and a guardrail, replace 5' sidewalk with 12' trail to accommodate bicycle/pedestrian traffic, add temporary curb ramps, pavement markings and sidewalk to maintain pedestrian traffic to the high school, install a retaining wall, and add sixty-five (65) days to the contract completion time. Change Order #2 in the amount of \$69,496.22 was approved by the Board of County Commissioners on March 1, 2016, and included various items that include: modify the signal at Old Highway 50, adjust for elevation differences, add permanent and temporary sidewalks, reconstruct curbs, add pedestrian school access, modify the trail along Old Highway 50 West, add asphalt overbuild, modify maintenance of traffic plan, construct a left turn lane onto Old

Highway 50 West, and add four (4) days to the contract completion time.

Included within change order #3 is a deduct amount of \$42,864.00 to remove the final asphalt lift from the contract. This work is proposed to be completed by the vendor for the Interchange project as if it was one contiguous project (contract award item scheduled for approval by the Board of County Commissioners on July 12, 2016).

Total adjusted contract with the approval of change orders #1, #2, and #3 is \$8,557,914.11.

Tracking No. W&R08042

Fiscal Impact: \$39,957.31 (Expenditure)

Account No.:

Fund Name	Fund Number	Org Code	Object Code	Project Number	Amount
Road Impact Fee South Benefit District Fund	1157	5056670 - South Transportation Benefit District	860674 - Infrastructure - Construction		\$39,957.31

Advertised Date:

Paper:

Attachments:

1.	Change Order #3
2.	Back Up Documents

STAFF APPROVALS AND DATES:

Deb Marchese	Created/Initiated - 06/23/2016
Lori Koontz	Approved - 06/23/2016
Debi Tinis	Approved - 06/23/2016
Sandy Beckett	Approved - 06/24/2016
Binh Nguyen	Approved - 06/27/2016
Richard Varner	Approved - 06/27/2016
Steve Koontz	Approved - 06/28/2016
Melanie Marsh	Approved - 06/28/2016
Niki Booth	Final Approval - 06/29/2016

ACTION TAKEN BY BOARD:

Action: New

Continued/Deferred Until:

Other:

MEMORANDUM

PUBLIC WORKS DEPARTMENT
ROAD OPERATIONS DIVISION
323 NORTH SINCLAIR AVENUE
TAVARES, FL 32778



LAKE COUNTY
FLORIDA

P. 352-253-6007
F. 352-253-6016
www.lakecountyfl.gov

To: Niki Booth, County Manager's Office
From: Deb Marchese, Public Works *Deb*
Date: July 26, 2016
Subject: Agenda Item #2983 – North Hancock Road Extension and Widening Phase IIIA and IIIB
Project No. 2014-11

Attached for the Chairman's signature is an original Contract Change Order #3 for the above referenced agenda item. This agenda item was approved at the July 12, 2016, Board meeting. The change order amount was changed after the first original was sent to you and the corrected Change Order #3 was not forwarded to you. Subsequently, the Chairman signed the incorrect Change Order. The Change Order that was in Suite One was correct and the Board approved it for the correct amount. Please return the original document to me once it is executed.

Please let me know if you have any questions.

/dcm

**BOARD OF COUNTY COMMISSIONERS
LAKE COUNTY, FLORIDA
OFFICE OF THE COUNTY MANAGER
AGENDA ITEM COVER SHEET**

DATE: 06/23/2016

MEETING DATE: 07/12/2016

TO: David Heath, County Manager

ITEM TYPE: Consent Item

THRU:

Lori Koontz, Road Ops Division Manager
Jim Stivender, Public Works Director

ITEM ID: 2983

BY: Deb Marchese, Construction Program Specialist

SUBJECT: North Hancock Road Extension Phase IIIA and IIIB Project No. 2014-11

RECOMMENDATION/REQUIRED ACTION:

Request approval for the Chairman to execute Change Order #3 to the North Hancock Road Extension and Widening Phase IIIA and IIIB Project No. 2014-11, Bid No. 14-0030, to Pospiech Contracting. Change Order #3 is for modifications of various items to include: pedestrian safety, concrete ditch paving, milling and resurfacing, paving and maintenance of traffic, concrete gravity wall and guiderail, trail ramps, full depth construction, survey, sidewalk, stormwater pipe and structures, driveway milling and resurfacing, and add sixty (60) days to the contract completion time. The net total cost of the work is \$39,957.31 to be funded by Road Impact Fee South Benefit District Fund. Commission District 2

BACKGROUND SUMMARY:

On October 28, 2014, the Board of County Commissioners awarded the construction of the North Hancock Road Extension and Widening Phase IIIA and IIIB Project No. 2014-11 to Pospiech Contracting, Inc. in the amount of \$8,430,070.44. The project consists of constructing and widening North Hancock Road to a four-lane urban designed roadway with curb and gutter, bike lanes, sidewalks, and multi-use trail. The project extends from CR-50 and runs north to the proposed new turnpike interchange.

Contractor change order summary: Change Order #1 in the amount of \$18,390.14 is within the County Manager's approval authority and included the following: delete two gravity walls and a guardrail, replace 5' sidewalk with 12' trail to accommodate bicycle/pedestrian traffic, add temporary curb ramps, pavement markings and sidewalk to maintain pedestrian traffic to the high school, install a retaining wall, and add sixty-five (65) days to the contract completion time. Change Order #2 in the amount of \$69,496.22 was approved by the Board of County Commissioners on March 1, 2016, and included various items that include: modify the signal at Old Highway 50, adjust for elevation differences, add permanent and temporary sidewalks, reconstruct curbs, add pedestrian school access, modify the trail along Old Highway 50 West, add asphalt overbuild, modify maintenance of traffic plan, construct a left turn lane onto Old

Highway 50 West, and add four (4) days to the contract completion time.

Included within change order #3 is a deduct amount of \$42,864.00 to remove the final asphalt lift from the contract. This work is proposed to be completed by the vendor for the Interchange project as if it was one contiguous project (contract award item scheduled for approval by the Board of County Commissioners on July 12, 2016).

Total adjusted contract with the approval of change orders #1, #2, and #3 is \$8,557,914.11.

Tracking No. W&R08042

Fiscal Impact: \$39,957.31 (Expenditure)

Account No.:

Fund Name	Fund Number	Org Code	Object Code	Project Number	Amount
Road Impact Fee South Benefit District Fund	1157	5056670 - South Transportation Benefit District	860674 - Infrastructure - Construction		\$39,957.31

Advertised Date:

Paper:

Attachments:

1.	Change Order #3
2.	Back Up Documents

STAFF APPROVALS AND DATES:

Deb Marchese Created/Initiated - 06/23/2016
Lori Koontz Approved - 06/23/2016
Debi Tinis Approved - 06/23/2016
Sandy Beckett Approved - 06/24/2016
Binh Nguyen Approved - 06/27/2016
Richard Varner Approved - 06/27/2016
Steve Koontz Approved - 06/28/2016
Melanie Marsh Approved - 06/28/2016
Niki Booth Final Approval - 06/29/2016

ACTION TAKEN BY BOARD:

Action: Approved

Continued/Deferred Until:

Other:

APPROVED	Tab 16. Request from Public Works for approval of Resolution 2016-74 authorizing the posting of 25 MPH speed limit signs on Mission Avenue (4059A) and Oakshade Drive (4059) in the Tavares area, Section 3, Township 22, Range 26. There is no fiscal impact. Commission District 3	STIVENDER
APPROVED	Tab 17. Request from Public Works for approval of a Resolution 2016-75 authorizing the posting of 25 MPH speed limit signs on Vista Verde Drive (2057) and Vista Bella Court (2058) in Section 3, Township 22, Range 26. There is no fiscal impact. Commission District 2	STIVENDER
APPROVED	Tab 18. Request from Public Works for approval for the Chairman to execute Change Order #3 to the North Hancock Road Extension and Widening Phase IIIA and IIIB Project No. 2014-11, Bid No. 14-0030, to Pospiech Contracting. Change Order #3 is for modifications of various items to include: pedestrian safety, concrete ditch paving, milling and resurfacing, paving and maintenance of traffic, concrete gravity wall and guiderail, trail ramps, full depth construction, survey, sidewalk, stormwater pipe and structures, driveway milling and resurfacing, and add sixty (60) days to the contract completion time. The net total cost of the work is \$39,957.31 to be funded by Road Impact Fee South Benefit District Fund. Commission District 2	STIVENDER
APPROVED	Tab 19. Request from Public Works for approval of a sole source award and associated Agreement between Lake County and The Middlesex Corporation relating to North Hancock Road and the connection to the FDOT Minneola Interchange project in the amount of \$42,820.00 to be expended from the Road Impact Fee South Benefit District Fund. The fiscal impact: \$42,820.00 (Expenditure). Commission District 2	STIVENDER
APPROVED	Tab 20. Request from Public Works for approval to award Royal Trails Stormwater Drainage Improvements, Project No. 2016-05; Bid No. 16-0028, Tracking No. STR06028, to Estep Construction, Inc. (Tavares, FL), in the amount of \$193,849.75, and to encumber and expend funds in the amount of \$193,849.75 from the Stormwater MSTU Construction fund. The fiscal impact is \$193,849.75. Commission District 5	STIVENDER
APPROVED	Tab 21. Request from Public Works for approval to advertise for bids for the Oswalt Road (0840) Widening and Resurfacing project at an estimated cost of \$975,000.00 from the Renewal Sales Tax Capital Project fund. The fiscal impact is \$975,000.00. Commission District 2	STIVENDER
APPROVED	Tab 22. Adoption of Ordinance 2016-31 amending Chapter 8, Section 8-2, Lake County Code, regarding the jurisdiction and powers of the Lake County	MARSH

Contract Change Order

**Lake County
Department of Public Works
323 North Sinclair Avenue
Tavares, FL 32778**

Date: 6/15/2016
Project No.: 2014-11
N. Hancock Rd Ext
Ph IIIA&IIIB
Location:
Contract No: 20150779
Change Order #: 3

To: **Pospiech Contracting, Inc.
201 South Apopka Avenue
Inverness, FL 34452**

**YOU ARE HEREBY REQUESTED TO COMPLY WITH THE FOLLOWING CHANGES FOR THE AGREEMENT,
PLANS AND SPECIFICATIONS**

ITEM NO.	DESCRIPTION IN CHANGES - QUANTITIES, UNITS, UNIT PRICES, CHANGE IN COMPLETION SCHEDULE, ETC.	DECREASE IN CONTRACT PRICE	INCREASE IN CONTRACT PRICE
1	Pedestrian safety modifications at Minneola High School entrance and add sixty (60) days to the contract completion time per attached exhibit "A" (CO-03-01).		\$ 38,444.95
2	Concrete ditch paving modifications per attached exhibit "A" (CO-03-02). Where ditch paving was deleted same replaced with additional sodding.	\$ 45,935.48	
3	Additional milling and resurfacing on North Hancock Road to correct pavement surface affected by MOT temporary pavement marking per attached exhibit "A" (CO-03-03).		\$ 21,530.70
4	Delete paving and MOT work and devices on Northbound and Southbound North Hancock Road per attached exhibit "A" (CO-03-04). <i>This work to be addressed by FDOT contractor as part of the Interchange project.</i>	\$ 35,628.08	
5	Concrete gravity wall and gulderail modifications (additions and deletions) per attached exhibit "A" (CO-03-05). At location where gravity walls were deleted same replaced with sodding.	\$ 18,470.17	
6	FDOT ADA trail ramp modifications to remedy steep profile slopes per attached exhibit "A" (CO-03-06).		\$ 4,913.18
7	Full depth construction on Southbound North Hancock Road to conform to Interchange project alignment per attached exhibit "A" (CO-03-07).		\$ 49,325.36
8	Additional survey required at Old 50 West and Gatewood to determine field conditions not shown on construction plans per attached exhibit "A" (CO-03-08).		\$ 6,600.00
9	Remove and reconstruct type F curb to correct survey error shown on construction plans per attached exhibit "A" (CO-03-09).		\$ 5,768.70
10	Additional 24" RCP to conform to Interchange project alignment per attached exhibit "A" (CO-03-10).		\$ 10,006.50
11	Additional 4" concrete sidewalk to conform to Interchange project alignment per attached exhibit "A" (CO-03-11).		\$ 2,214.45

Continued on next page

Continued from previous page

Contract Change Order

**Lake County
Department of Public Works
323 North Sinclair Avenue
Tavares, FL 32778**

Date: 6/15/2016
Project No.: 2014-11
Location: N. Hancock Rd Ext
Ph IIIA&IIIB
Contract No: 20150779
Change Order #: 3

To: **Pospiech Contracting, Inc.
201 South Apopka Avenue
Inverness, FL 34452**

YOU ARE HEREBY REQUESTED TO COMPLY WITH THE FOLLOWING CHANGES FOR THE AGREEMENT, PLANS AND SPECIFICATIONS			
ITEM NO.	DESCRIPTION IN CHANGES - QUANTITIES, UNITS, UNIT PRICES, CHANGE IN COMPLETION SCHEDULE, ETC.	DECREASE IN CONTRACT PRICE	INCREASE IN CONTRACT PRICE
12	Additional storm structure construction to conform to Interchange project alignment per attached exhibit "A" (CO-03-12).		\$ 4,825.00
13	Delete driveway milling and resurfacing at STA 81+25 (Big Sky Court)	\$ 3,637.80	
	Adjusted contract completion date is July 12, 2016 .		
	Change in contract price due to change order:		
	Total Decrease	\$ 103,671.53	
	Total Increase		\$ 143,628.84
	Difference		\$ 39,957.31
	Net Increase /Decrease Contract Price		\$ 39,957.31

The sum of **\$39,957.31** is hereby ~~added to~~/subtracted from the total agreement price, and the total adjusted agreement price to date thereby is **\$8,557,914.11**. This document shall become an amendment to the agreement and all other provisions of the agreement shall apply hereto.

Recommended by:

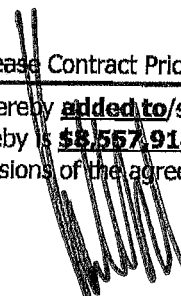
Jim Stivender, Jr., P.E., P.L.S., Director, Dept. of Public Works

Date: 7/6/2016

Accepted by:

Richard L. Pospiech, President, Pospiech Contracting, Inc.

Date: 7-26-2016

Approved by:

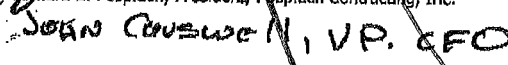
Sean M. Parks, Chairman, Lake County Board of County Commissioners

Date: _____

To be funded from Account #1157.5056670.860674



EXHIBIT A

NAME OF PROJECT: North Hancock Road Extension Phase IIIA and IIIB
FINANCIAL PROJECT ID: 435515-1-58-01
LAKE COUNTY PROJECT NUMBER: 2014-11
NAME OF CONTRACTOR: Pospiech Contracting, Inc.
SUBJECT: Change Order No. 03 (CO-03) Summary
DATE: June 23, 2016 (REVISED June 28, 2016)
FILE NO.: 6.0 (06-23-2016_CO-03_Summary)

REQUIRED CHANGES:

The following Change Order items CO-03-01 through CO-03-13 addresses required Work elements added to or deleted from the construction. Contract Duration adjustment is also addressed. CO-03 cost increase is at **\$39,957.31** and Sixty (60) calendar day increase in contract duration.

CONTRACT COST ADJUSTMENT:

CO-03-01: Lake County Direct Request for Proposal: Additional Pedestrian Safety Modifications and Additions at Minneola HS Main Entrance Crossing of N Hancock Road to / from Minneola HS Main Entrance at Fox Trail Ave. Work includes installation of Pedestrian Actuated Flashing Safety Beacons. Work includes reconstruction of the Minneola HS Main Entrance Crossing of N Hancock Road to / from Minneola HS Main Entrance at Fox Trail Ave roadway median safe haven. At High School Main Entrance curb was removed and reinstalled and additional 4" sidewalk on school property. Additionally, two (2) each DWS's not shown for installation at the median safe haven by the original bid plans are included as part of CO-03-06 below.

The Contractor proposed this Work at a cost increase of \$38,444.95 and Sixty (60) calendar days increase to contract duration. Contractor Final Completed would be revised to on or before July 12, 2016. LCPW and the contractor and his signal subcontractor directly negotiated this proposed change.

CO-03-02: Concrete Ditch Paving: Concrete Ditch Paving deleted and added from the work. At location where ditch paving was deleted same replaced with additional sodding.

The Contractor proposed this Work at a cost decrease of (\$45,935.48) and no modification to Contract Duration. From Tierra's review of the Contractor's provided cost data and quantities listed his proposal appears consistent with the requested modified Work and with his Bid Values. Therefore, Tierra hereby recommends acceptance of this proposed Work as proposed.

CO-03-03: North Bound N Hancock Rd Additional Milling and Resurfacing: Milling and Asphalt Resurfacing limits were extended to correct pavement surface affected by MOT temporary pavement marking.

The Contractor proposed this added Work at a cost increase of \$21,530.70 and no increase to Contract Duration. From Tierra's review of the Contractor's provided cost data and quantities listed his proposal appears consistent with the requested modified Work and with his Bid Values. Therefore, Tierra hereby recommends acceptance of this proposed Work as proposed.

CO-03-04: North Bound and South Bound N Hancock Rd Deleted FC Paving and Additional MOT work and devices. This item addresses construction coordination with Turnpike Construction Phase of N Hancock Rd. Deleted FC paving is to be placed as part of Turnpike Construction Phase construction. MOT elements to be transferred to the Turnpike contract for maintenance and final removal as part of the Turnpike Construction Phase work upon closure of the North Hancock Road Extension Phase IIIA and IIIB project.

The Contractor proposed this deleted and added work at a cost decrease of (\$35,628.08) and no increase to Contract Duration. From Tierra's review of the Contractor's provided cost data and quantities listed his proposal appears consistent with the requested modified Work and with his Bid Values. Therefore, Tierra hereby recommends acceptance of this proposed Work as proposed.

CO-03-05: Concrete Gravity Wall and Guiderail: Concrete Gravity Wall and Guiderail deleted and added from the work. At location where Gravity Walls were deleted same replaced with additional sodding.

The Contractor proposed this deleted and added Work at a cost decrease of (\$18,470.17) and no increase to

Contract Duration (see attached proposal marked Exhibit 5. From Tierra's review of the Contractor's provided cost data and quantities listed his proposal appears consistent with the requested modified Work and with his Bid Values. Therefore, Tierra hereby recommends acceptance of this proposed Work as proposed.

CO-03-06: FDOT ADA Ramp Modifications: Due to steep profile slope of the Trail ramps had to be extended to conform to FDOT ADA construction requirements. Plans indicated ramp width from 10' to 11.5'. To match trail width ramps were constructed at typical 12' width. Required adjustments increased trail ramp 4" concrete quantity and Detectable Warning Surface (DWS) quantity. Additionally, two (2) each DWS's not shown for installation at the median safe haven by the original bid plans are included as part of this item CO-03-06.

The Contractor proposed this modification to the Work at a cost increase of \$4,913.18 and no change to Contract Duration. From Tierra's review of the Contractor's provided cost data and quantities listed his proposal appears consistent with the requested modified Work and with his Bid Values. Therefore, Tierra hereby recommends acceptance of this proposed Work as proposed.

CO-03-07: Due to roadway alignment shift of N Hancock Rd from Gatewood Ave to north project limits to conform too Turnpike construction alignment Full Depth Construction SB N Hancock Rd was required. The Original plans required milling and resurfacing in the subject area.

The Contractor proposed this modification to the Work at an increase cost of \$49,325.36 and no increase to Contract Duration. From Tierra's review of the Contractor's provided cost data and quantities listed his proposal appears consistent with the requested modified Work and with his Bid Values. Therefore, Tierra hereby recommends acceptance of this proposed Work as proposed.

CO-03-08: Old 50 West and Gatewood Additional Survey: Additional contractor provided survey performed to: (1) Determine field conditions not indicated by the plans; and (2) Resurvey area at LCPW / Tierra provided revised elevations and grades.

The Contractor proposed this modification to the Work at an increase cost of \$6,600.00 and no change to Contract Duration. From Tierra's review of the Contractor's provided cost data and quantities listed his proposal appears consistent with the requested modified Work and with his Bid Values. Therefore, Tierra hereby recommends acceptance of this proposed Work as proposed.

CO-03-09: Plan Survey Correction Area: Plan Survey Area Error resulted in the removal and reconstruction of 200 LF of Type F Curb and Reconstruction of a 200' x 33' area of subgrade.

The Contractor proposed this modification to the Work at an increase cost of \$5,768.70 and no change to Contract Duration. From Tierra's review of the Contractor's provided cost data and quantities listed his proposal appears consistent with the requested modified Work and with his Bid Values. Therefore, Tierra hereby recommends acceptance of this proposed Work as proposed.

CO-03-10: Due to roadway alignment shift of N Hancock Rd from Gatewood Ave to north project limits to conform too Turnpike construction alignment additional 24" RCP was required for installation.

The Contractor proposed this modification to the Work at an increase cost of \$10,006.50 and no change to Contract Duration. From Tierra's review of the Contractor's provided cost data and quantities listed his proposal appears consistent with the requested modified Work and with his Bid Values. Therefore, Tierra hereby recommends acceptance of this proposed Work as proposed.

CO-03-11: Due to roadway alignment shift of N Hancock Rd from Gatewood Ave to north project limits to conform too Turnpike construction alignment additional 4" concrete sidewalk was required for installation.

The Contractor proposed this modification to the Work at an increase cost of \$2,214.45 and no change to Contract Duration. From Tierra's review of the Contractor's provided cost data and quantities listed his proposal appears consistent with the requested modified Work and with his Bid Values. Therefore, Tierra hereby recommends acceptance of this proposed Work as proposed.

CO-03-12: Due to roadway alignment shift of N Hancock Rd from Gatewood Ave to north project limits to conform too Turnpike construction alignment additional storm system structures construction was required.

The Contractor proposed this modification to the Work at an increase cost of \$4,825.00 and no change to Contract Duration. From Tierra's review of the Contractor's provided cost data and quantities listed his proposal appears consistent with the requested modified Work and with his Bid Values. Therefore, Tierra hereby recommends acceptance of this proposed Work as proposed.

CO-03-13: Per LCPW delete driveway milling and resurfacing at STA 81+25, Right.

The Contractor proposed this modification to the Work at a decrease cost of (\$3,637.80) and no change to Contract Duration. From Tierra's review of the Contractor's provided cost data and quantities listed his proposal appears consistent with the requested modified Work and with his Bid Values. Therefore, Tierra hereby recommends acceptance of this proposed Work as proposed.

CONTRACT DURATION ADJUSTMENT:

Sixty (60) Days are added to Contract Duration by this CO-03. Contractor's contract duration increase request is provided from information provided by Actuated Flashing Safety Beacons manufacturer and it is understood this time request is an estimate only and is beyond the direct control of the contractor. If system components are not supplied for installation on or before June 27, 2016 then additional time would be addressed by separate change order at that time.

PAYMENT:

Item No.	Description	Net Increase (Decrease) Quantity	Unit	Unit Price	Net Increase (Decrease) Price
CO-03-01	ADDITIONAL PEDESTRIAN SAFETY MODIFICATIONS AND ADDITIONS AT MINNEOLA HS MAIN ENTRANCE CROSSING OF N HANCOCK ROAD TO / FROM MINNEOLA HS MAIN ENTRANCE AT FOX TRAIL AVE	ALL	LS	\$38,444.95	\$38,444.95
CO-03-02	CONCRETE DITCH PAVING	ALL	LS	(\$45,935.48)	(\$45,935.48)
CO-03-03	NORTH BOUND N HANCOCK RD ADDITIONAL MILLING AND RESURFACING	ALL	LS	\$21,530.70	\$21,530.70
CO-03-04	NORTH BOUND AND SOUTH BOUND N HANCOCK RD DELETED FC PAVING AND ADDITIONAL MOT WORK AND DEVICES	ALL	LS	(\$35,628.08)	(\$35,628.08)
CO-03-05	CONCRETE GRAVITY WALL AND GUIDERAIL	ALL	LS	(\$18,470.17)	(\$18,470.17)
CO-03-06	FDOT ADA RAMP MODIFICATIONS	ALL	LS	\$4,913.18	\$4,913.18
CO-03-07	FULL DEPTH CONSTRUCTION SB N HANCOCK RD AND OTHER MISCELLANEOUS MODIFICATIONS	ALL	LS	\$49,325.36	\$49,325.36
CO-03-08	OLD 50 WEST ASPHALT OVERBUILD ADDITIONAL SURVEY	ALL	LS	\$6,600.00	\$6,600.00
CO-03-09	PLAN SURVEY CORRECTION AREA (200' TYPE F CURB REMOVE AND REPLACE; 200' X 33' AREA SUBGRADE RECONSTRUCTION)	ALL	LS	\$5,768.70	\$5,768.70
CO-03-10	ADDITIONAL 24" RCP AT 210 LF	ALL	LS	\$10,006.50	\$10,006.50
CO-03-11	ADDITIONAL 4" CONCRETE SIDEWALK AT 77.7 SY	ALL	LS	\$2,214.45	\$2,214.45
CO-03-12	ADDITIONAL STORM STRUCTURE AND STORM STRUCTURE MODIFICATIONS	ALL	LS	\$4,825.00	\$4,825.00
CO-03-13	DELETE DRIVEWAY MILLING AND RESURFACING, STA 81+25, RT	ALL	LS	(\$3,637.80)	(\$3,637.80)
TOTAL CHANGE ORDER NO. 03					\$39,957.31

Sincerely,

Robert P. Rudd, P.E.
Senior Project Engineer
TIERRA, INC.

591 Susan B. Britt Court | Winter Garden, Florida 34787
T 407-877-1354 | F 407-654-7347 | C 407-461-1564
www.tierraeng.com | rrudd@tierraeng.com
geotechnical environmental materials engineering

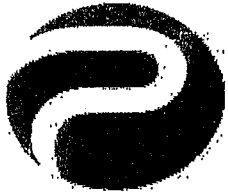

POSPIECH

— CONTRACTING —

NAME OF PROJECT: North Hancock Road Extension Phase IIIA and IIIB
FINANCIAL PROJECT ID: 435515-1-58-01
LAKE COUNTY PROJECT NUMBER: 2014-11
NAME OF CONTRACTOR: Pospiech Contracting, Inc.
SUBJECT: Change Order No. 03 (CO-03) Summary
DATE: June 9, 2016 (REVISED 06-16-2016)(REVISED 06-23-2016)(REVISED 06-28-2016)
FILE NO.: 6.0 (06-06-2016_CO-03_Summary)

REQUIRED CHANGES:

The following Change Order Items CO-03-01 through CO-03-08 addresses required Work elements added to or deleted from the construction. Contract Duration adjustment is also addressed. CO-03 cost increase is at \$39,957.31 and Sixty (60) calendar day increase in contract duration. More time may need to be added should delays in the proposed Beacons changes take additional time.

CONTRACT COST ADJUSTMENT:

CO-03-01: Lake County Direct Request for Proposal: Additional Pedestrian Safety Modifications and Additions at Minneola HS Main Entrance Crossing of N Hancock Road to / from Minneola HS Main Entrance at Fox Trail Ave. Work includes installation of Pedestrian Actuated Flashing Safety Beacons. Work includes reconstruction of the Minneola HS Main Entrance Crossing of N Hancock Road to / from Minneola HS Main Entrance at Fox Trail Ave roadway median safe haven. At High School Main Entrance curb was removed and reinstalled and additional 4" sidewalk on school property. Additionally, two (2) each DWS's not shown for installation at the median safe haven by the original bid plans are included as part of CO-03-06 below.

Pospiech Contracting, Inc. proposed this Work at a cost increase of \$38,444.95 and Sixty (60) calendar days increase to contract duration (see attached proposal marked Exhibit 1). Contractor Final Completed would be revised to on or before July 12, 2016. LCPW and the contractor and his signal subcontractor directly negotiated this proposed change.

CO-03-02: Concrete Ditch Paving: Concrete Ditch Paving deleted and added from the work. At location where ditch paving was deleted same replaced with additional sodding.

Pospiech Contracting, Inc. proposed this Work at a cost decrease of (\$45,935.48) and no modification to Contract Duration (see attached proposal marked Exhibit 2). From Pospiech Contracting, Inc. provided cost data and quantities listed consistent with the requested modified Work and with his Bid Values.

CO-03-03: North Bound N Hancock Rd Additional Milling and Resurfacing: Milling and Asphalt Resurfacing limits were extended to correct pavement surface affected by MOT temporary pavement marking.

Pospiech Contracting, Inc. proposed this added Work at a cost increase of \$21,530.70 and no increase to Contract Duration (see attached proposal marked Exhibit 3).

CO-03-04: North Bound and South Bound N Hancock Rd Deleted FC Paving and Additional MOT work and devices. This item addresses construction coordination with Turnpike Construction Phase of N Hancock Rd. Deleted FC paving is to be placed as part of Turnpike Construction Phase construction. MOT elements to be transferred to the Turnpike contract for maintenance and final removal as part of the Turnpike Construction Phase work upon closure of the North Hancock Road Extension Phase IIIA and IIIB project.

Pospiech Contracting, Inc. proposed this deleted and added work at a cost decrease of (\$35,628.08) and no increase to Contract Duration (see attached proposal marked Exhibit 4). Pospiech Contracting, Inc. provided cost data and quantities listed his proposal

CO-03-05: Concrete Gravity Wall and Guiderail: Concrete Gravity Wall and Guiderail deleted and added from the work. At location where Gravity Walls were deleted same replaced with additional sodding.

Pospiech Contracting, Inc. proposed this deleted and added Work at a cost decrease of (\$18,470.17) and no increase to Contract Duration (see attached proposal marked Exhibit 5).

CO-03-06: FDOT ADA Ramp Modifications: Due to steep profile slope of the Trail ramps had to be extended to conform to FDOT ADA construction requirements. Plans indicated ramp width from 10' to 11.5'. To match trail width ramps were constructed at typical 12' width. Required adjustments increased trail ramp 4" concrete quantity and Detectable Warning Surface (DWS) quantity. Additionally, two (2) each DWS's not shown for installation at the median safe haven by the original bid plans are included as part of this item CO-03-06.

The Contractor proposed this modification to the Work at a cost increase of \$4,913.18 and no change to Contract Duration (see attached proposal marked Exhibit 6). Pospiech Contracting, Inc. provided cost data and quantities listed his proposal.

CO-03-07: Due to roadway alignment shift of N Hancock Rd from Gatewood Ave to north project limits to conform too Turnpike construction alignment Full Depth Construction SB N Hancock Rd was required. The Original plans required milling and resurfacing in the subject area.

Pospiech Contracting, Inc. proposed this modification to the Work at an increase cost of \$49,325.36 and no increase to Contract Duration (see attached proposal marked Exhibit 7). Pospiech Contracting, Inc. provided cost data and quantities.

CO-03-08: Old 50 West and Gatewood Additional Survey: Additional contractor provided survey performed to: (1) Determine field conditions not indicated by the plans; and (2) Resurvey area at LCPW / Tierra provided revised elevations and grades.

Pospiech Contracting, Inc. proposed this modification to the Work at an increase cost of \$6,600.00 and no change to Contract Duration (see attached proposal marked Exhibit 8). Pospiech Contracting, Inc. provided cost data and quantities listed the proposal .

CO-03-09: Plan Survey Correction Area: Plan Survey Area Error resulted in the removal and reconstruction of 200 LF of Type F Curb and Reconstruction of a 200' x 33' area of subgrade.

Pospiech Contracting, Inc. proposed this modification to the Work at an increase cost of \$5,768.70 and no change to Contract Duration (see attached proposal marked Exhibit 9). Pospiech Contracting Inc. provided cost data and quantities listed in the proposal...

CO-03-10: Due to roadway alignment shift of N Hancock Rd from Gatewood Ave to north project limits to conform too Turnpike construction alignment additional 24" RCP was required for installation.

Pospiech Contracting, Inc. proposed this modification to the Work at an increase cost of \$10,006.50 and no change to Contract Duration (see attached proposal marked Exhibit 9). Pospiech Contracting, Inc. provided cost data and quantities .

CO-03-11: Due to roadway alignment shift of N Hancock Rd from Gatewood Ave to north project limits to conform too Turnpike construction alignment additional 4" concrete sidewalk was required for installation.

Pospiech Contracting, Inc. proposed this modification to the Work at an increase cost of \$2,214.45 and no change to Contract Duration (see attached proposal marked Exhibit 9). Pospiech Contracting, Inc. provided cost data and quantities.

CO-03-12: Due to roadway alignment shift of N Hancock Rd from Gatewood Ave to north project limits to conform too Turnpike construction alignment additional storm system structures construction was required.

Pospiech Contracting, Inc. proposed this modification to the Work at an increase cost of \$4,825.00 and no change to Contract Duration (see attached proposal marked Exhibit 8). Pospiech Contracting, Inc. provided cost data and quantities.

CO-03-13: Per LCPW delete driveway milling and resurfacing at STA 81+25, Right.

Pospiech proposes this modification to the Work at a decrease cost of (\$3,637.80) and no change to Contract Duration. From Pospiech's review of Tierra's cost data and quantities noted work credit appears consistent with the requested modified Work and with the Bid Values.

CONTRACT DURATION ADJUSTMENT:

Sixty (60) Days are added to Contract Duration by this CO-03. Contractor's contract duration increase request is provided from information provided by Actuated Flashing Safety Beacons manufacturer and it is understood this time request is an estimate only and is beyond the direct control of the contractor. If system components are not supplied for installation on or before June 27, 2016 then additional time would be addressed by separate change order at that time.

Please call if additional back-up is required.

Gary Bracken
Pospiech Contracting, Inc.

PAYMENT:

Item No.	Description	Net Increase (Decrease) Quantity	Unit	Unit Price	Net Increase (Decrease) Price
CO-03-01	ADDITIONAL PEDESTRIAN SAFETY MODIFICATIONS AND ADDITIONS AT MINNEOLA HS MAIN ENTRANCE CROSSING OF N HANCOCK ROAD TO / FROM MINNEOLA HS MAIN ENTRANCE AT FOX TRAIL AVE	ALL	LS	\$38,444.95	\$38,444.95
CO-03-02	CONCRETE DITCH PAVING	ALL	LS	(\$45,935.48)	(\$45,935.48)
CO-03-03	NORTH BOUND N HANCOCK RD ADDITIONAL MILLING AND RESURFACING	ALL	LS	\$21,530.70	\$21,530.70
CO-03-04	NORTH BOUND AND SOUTH BOUND N HANCOCK RD DELETED FC PAVING AND ADDITIONAL MOT WORK AND DEVICES	ALL	LS	(\$35,628.08)	(\$35,628.08)
CO-03-05	CONCRETE GRAVITY WALL AND GUIDERAIL	ALL	LS	(\$18,470.17)	(\$18,470.17)
CO-03-06	FDOT ADA RAMP MODIFICATIONS	ALL	LS	\$4,913.18	\$4,913.18
CO-03-07	FULL DEPTH CONSTRUCTION SB N HANCOCK RD AND OTHER MISCELLANEOUS MODIFICATIONS	ALL	LS	\$49,325.36	\$49,325.36
CO-03-08	OLD 50 WEST ASPHALT OVERBUILD ADDITIONAL SURVEY	ALL	LS	\$6,600.00	\$6,600.00
CO-03-09	PLAN SURVEY CORRECTION AREA (200' TYPE F CURB REMOVE AND REPLACE; 200' X 33' AREA SUBGRADE RECONSTRUCTION)	ALL	LS	\$5,768.70	\$5,768.70
CO-03-10	ADDITIONAL 24" RCP AT 210 LF	ALL	LS	\$10,006.50	\$10,006.50
CO-03-11	ADDITIONAL 4" CONCRETE SIDEWALK AT 77.7 SY	ALL	LS	\$2,214.45	\$2,214.45
CO-03-12	ADDITIONAL STORM STRUCTURE AND STORM STRUCTURE MODIFICATIONS	ALL	LS	\$4,825.00	\$4,825.00
CO-03-13	DELETE DRIVEWAY MILLING AND RESURFACING, STA 81+25, RT	ALL	LS	(\$3,637.80)	(\$3,637.80)
TOTAL CHANGE ORDER NO. 03					\$39,957.31

CO-03-01 BACKUP



April 18, 2016 (REVISED 06/16/2016)

Hancock Road Phases IIIA and IIIB

Re: Flashing Beacons at High School RFC 17A

Robert Rudd,

Lake County Direct Request for Proposal: Additional Pedestrian Safety Modifications and Additions at Minneola HS Main Entrance Crossing of N Hancock Road to / from Minneola HS Main Entrance at Fox Trail Ave. Work includes installation of Pedestrian Actuated Flashing Safety Beacons. Work includes reconstruction of the Minneola HS Main Entrance Crossing of N Hancock Road to / from Minneola HS Main Entrance at Fox Trail Ave roadway median safe haven. At High School Main Entrance curb was removed and reinstalled and additional 4" sidewalk on school property. Additionally, two (2) each DWS's not shown for installation at the median safe haven by the original bid plans are included as part of CO-03-06 below.

Pospiech Contracting, Inc. proposed this Work at a cost increase of \$38,444.95 and Sixty (60) calendar days increase to contract duration (see attached proposal marked Exhibit 1). Contractor Final Completed would be revised to on or before July 12, 2016. LCPW and the contractor and his signal subcontractor directly negotiated this proposed change.

Sincerely,

Gary Bracken

Pospiech Contracting, Inc.

Cost Information:

Pedestrian Actuated Flashing Safety Beacons at\$29,022.75;
Median Safe Haven and School Main Entrance Reconstruction at\$ 9,422.20;
CO-03-01 Total Cost at\$38,444.95.



Corporate Office:
242 North Westmonte Drive
Altamonte Springs, FL 32714

Ph: (407) 869-5300
Fax: (407) 682-0076

Website: www.TCD-USA.com

Local Offices:

Altamonte Springs, FL	Rockledge, FL
Clermont, FL	Tampa, FL
Deland, FL	Dallas, TX
Jacksonville, FL	Houston, TX
Oakland Park, FL	San Antonio, TX
Punta Gorda, FL	Salisbury, NC

To:	Posplech Contracting, Inc.	Contact:	Gary Bracken
Address:	201 South Apopka Avenue Inverness, FL 34452	Phone:	(352) 726-3940
Project Name:	15017000-4 Addition Of RRFB Flashers	Fax:	1 (800) 795-4959
Project Location:	Hancock Road, Lake County, FL	Bid Number:	14-0030
		Bid Date:	

Item #	Item Description	Estimated Quantity	Unit	Unit Price	Total Price
0654 2 21	RECTANGULAR RAPID FLASHING BEACON, FURNISH & INSTALL- SOLAR POWERED, COMPLETE ASSEMBLY- SINGLE DIRECTION	4.00	AMBY	\$6,405.30	\$25,621.20

Total Bid Price: \$25,621.20

Notes:

- This proposal is a lump sum proposal under unit price item No.76. The total sum is our price to perform the work required by the plans and specifications only.
- Our price includes insurance.
- All work is guaranteed to be installed in accordance with the latest applicable Code regulations, and to be free from mechanical and electrical defects for one year from the date of acceptance.
- No items quoted herein may be "broken out" without prior approval in writing.
- This proposal is valid for thirty (30) days from bid date.
- All QC managers, plans or testing (if required) shall be provided by others and is not included in this proposal.
- Electrical permit fees included in this proposal for electrical services associated with TCD work only. All other permits or fees shall be provided by others.
- Asphalt, Concrete, Sidewalk, Concrete aprons around pull boxes and Sodding removal and placement are **EXCLUDED** from this proposal and shall be provided by others.
- This change order proposal #4 is for the addition of (4) Rectangular Rapid Flashing Beacons (RRFB) assemblies.

Payment Terms:

Payments are to be made to us by the tenth day of the month for all work installed and materials placed on the job site during the preceding month, less five (5%) percent retainage (unless the Prime Contract calls for a different retainage percentage). Final Payment, including retainage, will be due not more than thirty (30) days after completion and acceptance of the work. Any contract resulting from this proposal shall be on the terms and conditions mutually acceptable to the Purchaser and Traffic Control Devices, Inc.

<p>ACCEPTED: The above prices, specifications and conditions are satisfactory and are hereby accepted.</p> <p>Buyer: <u>Gary Bracken</u></p> <p>Signature: <u>[Signature]</u></p> <p>Date of Acceptance: <u>5-2-14</u></p>	<p>CONFIRMED: Traffic Control Devices, Inc.</p> <p>Authorized Signature: _____</p> <p>Estimator: Michael Waldron 407-869-5300 m.waldron@tcd-usa.com</p>
--	---

**Pedestrian Actuated Flashing
Safety Beacons Cost
Information:**

**Proposed Change Order - Pospiech # 17A
Addition of Rapid Flashing Beacons at High School**

Furnish and install Rapid Flashing Beacons (TCD)	25,621.20 (TCD)
Install Concrete Apron around Pull Boxes & Misc Sod	1250.00 (Pospiech)
Additional MOT For Installation / Day	272.72 (Pospiech)
Asbuilt and Survey	405.00 (Pospiech)
Subtotal	27,548.92
Added Time To Contract	60 Calendar Days
Pospiech Mark-up on TCD (5%)	\$1281.06
Pospiech Direct Work Markup (10%)	\$192.77
Total Price for Change PCO 17A	\$29,022.75

Median Safe Haven and School Main Entrance Reconstruction Cost Information

DESCRIPTION: RPR		Date: 1.27.10		RPR		
A. Labor Requirements						
Description	Qty	Regular Hrs	Overtime Hrs	Labor Rate w/ Burden	Total Amount	Comments
MOT Supervisor	0.00	0.00	0.00	\$94.00	\$272.00	DEMO SCHOOL ISLAND
Excavator Operator	0.00	0.00	0.00	\$216.00	\$216.00	DEMO SCHOOL ISLAND
Loader	0.00	0.00	0.00	\$182.00	\$182.00	DEMO SCHOOL ISLAND
Trucking-Haul Oil	0.00	0.00	0.00	\$210.00	\$210.00	DEMO SCHOOL ISLAND
Loader Operator	0.00	0.00	0.00	\$204.00	\$204.00	DEMO SCHOOL ISLAND
	0.00	0.00	0.00	\$0.00	\$0.00	
	0.00	0.00	0.00	\$0.00	\$0.00	
	0.00	0.00	0.00	\$0.00	\$0.00	
	0.00	0.00	0.00	\$0.00	\$0.00	
	0.00	0.00	0.00	\$0.00	\$0.00	
Sub Total	0.00	0.00	0.00	\$0.00	\$1,070.00	
B. Equipment Requirements						
Description	Qty	Rate/Hr	Operating Cost/ Hr	Duration (Hrs)	Amount	
Main with Broom	0.00	\$23.40	\$20.00	0.00	\$214.00	
Loader Cat 950	0.00	\$20.64	\$05.00	0.00	\$310.00	
Dump Truck	0.00	\$85.00	\$60.00	0.00	\$520.00	
	0.00	\$0.00	\$0.00	0.00	\$0.00	
R/R 100 Cub With Type D on Plan Attached	0.00	\$28.46	\$20.00	0.00	\$107.20	
	0.00	\$0.00	\$0.00	0.00	\$0.00	
R/R 04 CY Subgrade	0.00	\$33.41	\$33.41	4.00	\$133.64	
	0.00	\$0.00	\$0.00	0.00	\$0.00	
	0.00	\$0.00	\$0.00	0.00	\$0.00	
	0.00	\$0.00	\$0.00	0.00	\$0.00	
	0.00	\$0.00	\$0.00	0.00	\$0.00	
	0.00	\$0.00	\$0.00	0.00	\$0.00	
Sub Total	0.00	\$2.00	\$0.00	0.00	\$1,206.64	
C. Material						
Description	Qty	Unit	Rate (w/ tax)	Amount		
Work Zone Signs	1.00	EA	\$1.40	\$1.40	1day	
Barms	10.00	EA	\$0.25	\$2.50	1day	
				\$0.00		
				\$0.00		
				\$0.00		
				\$0.00		
				\$0.00		
				\$0.00		
				\$0.00		
				\$0.00		
				\$0.00		
Sub Total				\$3.90		
D. Subcontractor Requirements						
Subcontractor	Qty	Unit	Rate (w/ tax)	Amount		
Center Island	1.00	LS		\$9,010.60	See Attached Sheet	
Install 10" of Type D Cont	100.00	LF	\$13.00	\$1,300.00		
10657 Concrete Sidewalk 20.02 SY	20.62	SY	\$32.60	\$700.07		
MSI per listed	1.00	SY	\$0.22	\$220.22		
Pave per Detail	4.00	SY	\$12.00	\$480.00		
Sub Total	41.00			\$9,930.89		
0% Mark-up (Subcontractor)				\$0.00		
E. Items with Unit Cost						
Description	Qty	Unit	Contract U.P. Rate	Amount		
				\$0.00		
				\$0.00		
				\$0.00		
				\$0.00		
				\$0.00		
Sub Total				\$0.00		
Totnl				\$9,186.24		
Markup on Labor			10.00%	\$107.00		
Markup on Materials			10.00%	\$0.40		
Markup on Equipment			10.00%	\$120.56		
Markup on Subcontractors (Posploch)			0.00%	\$0.00		
Bond/Insurance			0.00%	\$0.00		
Grand Total :				\$9,422.20		
REMARKS: Work and re work in front of School						

\$1,070.00 Direct Labor
 \$1,285.64 Equipment
 \$ 3.98 MOT Devices
 \$6,826.62 Sub's
 \$ 107.00 Labor Markup
 \$ 0.40 Mat Markup
 \$ 128.56 Equip Markup

 \$9,422.20 Total

 Sub's Cost Item Includes
 a Number of Bid
 Measured Unit Items
 Along with new work
 noted by attached
 invoice.

Subcontractor Work at Bid Unit
 Cost No Markup Allowed

Math Corrections 06/16/16
 RPR

Innovative Curbs, Inc.

Invoice

Date: 3/30/2016 Invoice #: 5417

7435 SW 32nd Street - Ocala, FL 3447
(352) 861-3843 - Fax (352) 861-3845

Bill To

Pospiech Contracting
201 South Apopka Avenue
Inverness, FL 34450

		Project	Due Date
		Hancock Rd.	4/29/2016
Quantity	Description	Rate	Amount
692.77	Form and Pour 4" Sidewalk (Labor and Materials)	21.15	14,652.09
519	Install 4" Traffic Separators (Labor and Materials)	28.00	14,532.00
2,759	Design Build H.C. Ramps (Labor and Materials)	5.50	15,174.50
24	Form and Pour 6" Driveway Apron (Labor and Materials)	31.50	756.00
975	Form and Pour "E" Curb (Labor and Materials)	10.50	10,237.50
1,370	Form and Pour "F" Curb (Labor and Materials)	9.50	13,015.00
943	Form and Pour "A" Curb (Labor and Materials)	9.50	8,958.50
		0.00	0.00
	Pork Chop Rework		
26	Form and Pour "E" Curb (Labor and Materials)	12.00	312.00
96	Install "B" Curb (Labor and Materials)	10.50	1,008.00
500	Form and Pour Sidewalk (Labor and Materials)	3.00	1,500.00
313	Form and Pour 6" Separator fill back of curb to Flat	3.50	1,095.50
			3,915.50
			Sub
		\$3,915.50	
<div style="border: 1px dashed black; padding: 5px; display: inline-block;"> Clouded Items Only Included As Part Of CO-03. </div>			
Thank you for your business.		Total	\$81,241.09

CO-03-02 BACKUP



May 5, 2016

Hancock Road Phase IIIA and IIIB

Robert Rudd,

Please see attached COR # 20 for Ditch Paving the overall Credit for Ditch Paving is (45,935.48)

Thank You,

Gary Bracken

5-May-16

Concrete Ditch Paving COR 20

Install Ditch Paving at Gatewood

Install 20.88 SY Ditch Paving @ Gatewood 51.00 SY
Total amount of change at Gatewood 1,064.88

Sodding and grading in place of Ditch Paving 992.12 SY
Sodding and Grading @ 4.70 total 4,662.64

Credit for unused ditch Paving (45,935.48)

CO-03-03 BACKUP



March 31, 2016

RE: North Hancock Road Phases IIIA & IIIB

Robert Rudd,

During the Pre Paving meeting it was discussed that Lake County may request additional milling and paving be added to the North bound Lanes of Hancock Road. We have just received notice at 1:30 today that Lake County would like to proceed with that additional work before we begin the final lift of paving. Pospiech Contracting is requesting a meeting at 8:00 a.m. Friday April 1, 2016 to confirm quantities and pricing.

Total Quantities (Area is 509' x 27') = 1527 SY
Pricing per contract pay items are as follows:

Hancock Road Phase III Pay application items are as follows

- A) Line Item 18 page 1- Mill 1 inch 6.25 SY x 1527 = 9543.75
- B) Line Item 12 page 1- 9.5 Friction 7.85 SY x 1527 = 11,986.95

Total Proposed Changed Order \$21,530.70

Please advise Pospiech Contracting by the 8:00 a.m. meeting if this proposal is accepted.

Best Regards,

Gary Brackén
Pospiech Contracting, Inc.

CO-03-04 BACKUP



June 9, 2016

Hancock Road Phase III A and III B

Robert Rudd,

North Bound and South Bound N Hancock Rd Deleted FC Paving and Additional MOT work and devices. This item addresses construction coordination with Turnpike Construction Phase of N Hancock Rd. Deleted FC paving is to be placed as part of Turnpike Construction Phase construction. MOT elements to be transferred to the Turnpike contract for maintenance and final removal as part of the Turnpike Construction Phase work upon closure of the North Hancock Road Extension Phase IIIA and IIIB project.

Pospiech Contracting, Inc. proposed this deleted and added work at a cost decrease of (\$35,628.08) and no increase to Contract Duration (see attached proposal marked Exhibit 4). Pospiech Contracting, Inc., provided cost data and quantities listed in proposal.

Sincerely,

Gary Bracken

Pospiech Contracting, Inc.

Cost Breakdown:

Pospiech Direct Cost	\$1,915.92
Subcontractor Costs	
Construction Merge Temp Markings, Stop Sign, R1-1 Sign	\$2,820.00
Construction Advance Warning Signs, Barrel Barricades and Speed Limit Signs	\$2,500.00
Delete FC Asphalt Paving	(\$42,864.00)
Total	(\$35,628.08)



**AKCA
INC.**

The Pavement Marking Company

4603 Recco Road,
Plant City, FL 33566
(813) 752-4471 Office
(813) 752-2357 Fax

Pospiech Contracting

Estimate

Number:
Bid Date:
Revised Date: 4/28/2018

PLANS DATED	TERMS	COUNTY	PROJECT	
	Net 30 Days	Lake	Hancock rd. o work 4-8-2018	
Item	Description	Quantities	Unit Price	Amount

1	Perm paint detour per plan with grinding	1,000	ls	\$ 1,500.00	\$ 1,500.00
2	Stop ahead sign	4,000	ea	\$ 220.00	\$ 880.00
3	R1-1 sign	2,000	ea	\$ 220.00	\$ 440.00
notes					
1	Prices are based one one mobilization				
2	Contractor to install signs				
Total					\$ 2,820.00

Bid quantities are approximate and will be invoiced per actual quantities installed.
 The bid price is based on actual cost at time of bid. Any change + or - will be adjusted at time of installation.
 This Proposal is contingent upon acceptance. A three week notice required before work begins.
 Fourteen (14) day notice for crew mobilization required. Retainage not to exceed 2.5% of Invoice.
 All work shall meet F.D.O.T. Specifications & Standards.
 This quotation may be withdrawn if not accepted within 30 days of proposal date.
 Above quote is package priced, line items will not be separated.
 There is a minimum additional charge of \$800 for working non-work regulated days, such as Friday evening, Saturday evening or Holidays.

Respectfully Submitted: _____
 Dale Bussey - Sales Manager

Please sign and return original upon acceptance.

Upon execution of this proposal this document becomes a contract.
 The above prices, specifications and conditions are satisfactory and are hereby accepted. We authorize Akca, Inc. to do the work specified. Payment will be made within 30 days of invoice date following completion of work. In the event that the amount herein is not paid when due, interest at the highest legal rate per annum shall accumulate on the total balance due. All costs of collection shall be paid by the customer including reasonable attorney fees.

Authorized Signature _____

Company Name _____

Date _____



**AKCA
INC.**

The Payment Marking Company

4603 Reese Road,
Plant City, FL 33566
(813) 752-4471 Office
(813) 752-2357 Fax

Pospisich Contracting

Estimate

Number:
Est. Date:
Revised Date:

PLANS DATED	TERMS	COUNTY	PROJECT	
	Net 30 Days	Lake	Hawthorn rd co work 4-8-2016	
Item	Description	Quantity	Unit Price	Amount

1	Construction Advance Warning Signs, Barrel Barricades and Speed Limit Signs (To Be Transferred To Turnpike Project)	1,000	ls	\$ 2,500.00	\$ 2,500.00
notes					
1	Prices are based on one mobilization				
2	Contractor to install signs				
				Total	\$ 2,500.00

All quantities are approximate and will be invoiced per actual quantities installed.
 Terms price is based on actual cost at time of bid. Any change + or - will be adjusted at time of installation.
 This Proposal is contingent upon acceptance. A three week notice required before work begins,
 Fourteen (14) day notice for crew mobilization required. Retainage not to exceed 2.5% of Invoice.
 All work shall meet F.D.O.T., Specifications & Standards.
 This quotation may be withdrawn if not accepted within 30 days of proposal date.
 Above quote is package priced, line items will not be separated.
 There is a minimum additional charge of \$200 for working non-work regulated days, such as Friday evening, Saturday evening or Holidays.

Respectfully Submitted,
 Dale Bussey - Sales Manager

Please sign and return original upon acceptance.

Upon execution of this proposal this document becomes a contract.
 The above prices, specifications and conditions are satisfactory and are hereby accepted. We authorize Akca, Inc. to do the work specified. Payment will be made within 30 days of invoice date following completion of work. In the event that the amount herein is not paid when due, interest at the highest legal rate per annum shall accumulate on the total balance due. All costs of collection shall be paid by the customer including reasonable attorney fees.

Authorized Signature _____ Date _____
 Company Name _____

Gary Bracken

From: Robert Rudd <rdudd@tierraeng.com>
Sent: Monday, April 25, 2016 10:03 AM
To: GBracken@pospiechcontracting.com
Cc: r.rudd@aol.com; Jscott@lakecountyfl.gov; Jhinton@lakecountyfl.gov; Jeffrey Begovich; 'Scott Smith' (ssmith@pospiechcontracting.com)
Subject: Hancock Rd NB North Limits Cost Data

Gary,

REVISED 6-16-2016
RPR:

Need value of FC-9.5 at 1" to be deleted north of Fosgate. STA 255+30 to STA 269+58.61 NB Lanes and Left Turn off NB into Gatewood. STA 268+53.61 to STA 269+58.61 SB Lanes. Calculated quantity and value follows:

Mainline:

North Bound: $26958.61 - 25530 = 1428.61$
 $(1428.61 \times 28) / 9 = 4445 \text{ SY}$

South Bound: $26958.61 - 26853.61 = 105$
 $(105 \times 28) / 9 = 327 \text{ SY}$

Left Turn:

$[(26093-26043) \times 16] / 2 / 9 = 44 \text{ SY} + [(26380-26093) \times 17] / 9 = 542 \text{ SY} = 586 \text{ SY}$

Total Quantity FC-9.5, 1" = 5358 SY

Total Value FC-9.5, 1" = $(5358 \text{ SY}) \times \$8.00/\text{SY} = (\$42,864.00)$ ✓

Total Deduct = (\$42,864.00)

Also need value for MOT Temp Signs and Markings for NB Hancock to be installed and to remain for others to maintain and remove.

Thanks,

I have calculated quantity and value of FC as follows:

Robert Rudd
Tierra, Inc.

Total Control Panel

[Login](#)

To: gbracken@pospiechcontracting.com
From: rdudd@tierraeng.com

Message Score: 2
My Spam Blocking Level: Medium

High (60); Pass
Medium (75); Pass
Low (90); Pass

[Block this sender](#)
[Block tierraeng.com](#)

This message was delivered because the content filter score did not exceed your filter level.

CO-03-05 BACKUP



June 9, 2016 (REVISED 6/28/2016)

Hancock Road Phase IIIA and IIIB

Robert Rudd,

Concrete Gravity Wall and Guiderail: Concrete Gravity Wall and Guiderail deleted and added from the work. At location where Gravity Walls were deleted same replaced with additional sodding.

Pospiech Contracting, Inc. proposed this deleted and added Work at a cost decrease of ~~(\$18,470.17)~~ and no increase to Contract Duration (see attached proposal marked Exhibit 5).

Thank you for your assistance in this matter.

Gary Bracken

Pospiech Contracting, Inc.

Cost Breakdown:

Gravity Wall Guiderail Deduct = 573 LF. Unit cost of Guiderail is at \$55.00/LF. Value of Deleted Guiderail at (\$31,515.00)
CO-03 Wall Guiderail Deduct = (\$31,515.00)

CO-03 Gravity Wall Deduct: = 143.72 CY. Unit Cost at \$337.25/CY. Value of Deleted Wall at (\$48,469.57)
CO-03 Wall Deduct = (\$48,469.57)

CO-03 CO-01 Wall Deduction Correction = \$61,514.40

Total CO-03 Wall Deduct = (\$18,470.17)

CO-03 Deduc Wall

EXHIBIT 5 BACKUP DOCUMENT

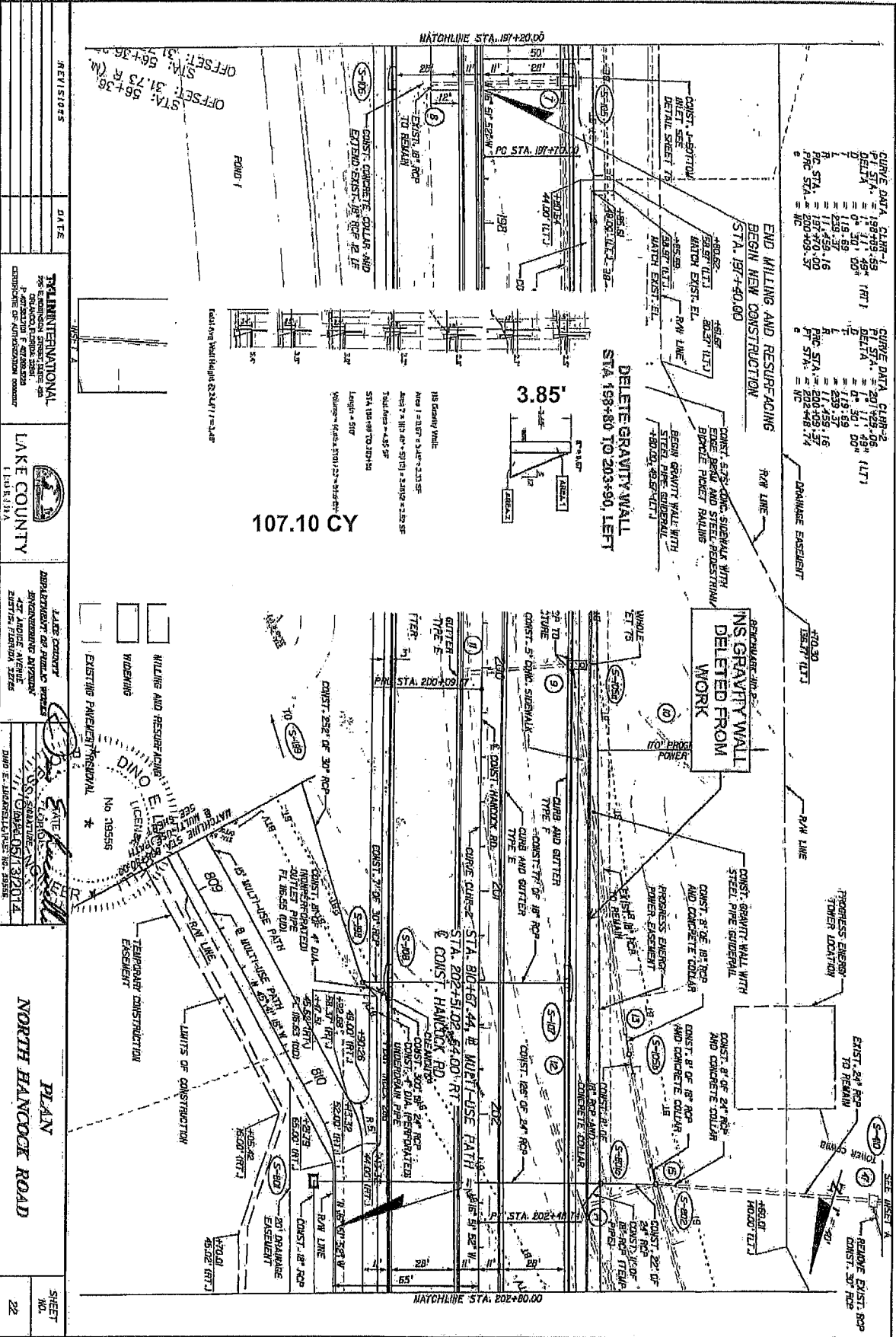

CURVE DATA CLAR-1

P.I. STA.	= 198+99.59
DELTA	= 111.49°
PC STA.	= 197+36.00
P.T. STA.	= 199+63.57

CURVE DATA CLAR-2

P.I. STA.	= 201+99.06
DELTA	= 111.49°
PC STA.	= 200+35.57
P.T. STA.	= 202+62.14



107.10 CY

<p>REVISIONS</p> <table border="1"> <tr><th>NO.</th><th>DATE</th><th>DESCRIPTION</th></tr> <tr><td> </td><td> </td><td> </td></tr> </table>	NO.	DATE	DESCRIPTION				<p>DATE</p>	<p>INTERNATIONAL</p>	<p>LAKE COUNTY</p>	<p>LAKE COUNTY</p>	<p>STATE OF FLORIDA</p>	<p>PLAN</p>	<p>SHEET</p>
NO.	DATE	DESCRIPTION											
<p>LAKE COUNTY</p>	<p>LAKE COUNTY</p>	<p>LAKE COUNTY</p>	<p>LAKE COUNTY</p>	<p>LAKE COUNTY</p>	<p>LAKE COUNTY</p>	<p>NORTH HANCOCK ROAD</p>	<p>22</p>						

CO-03 Deduct Wall

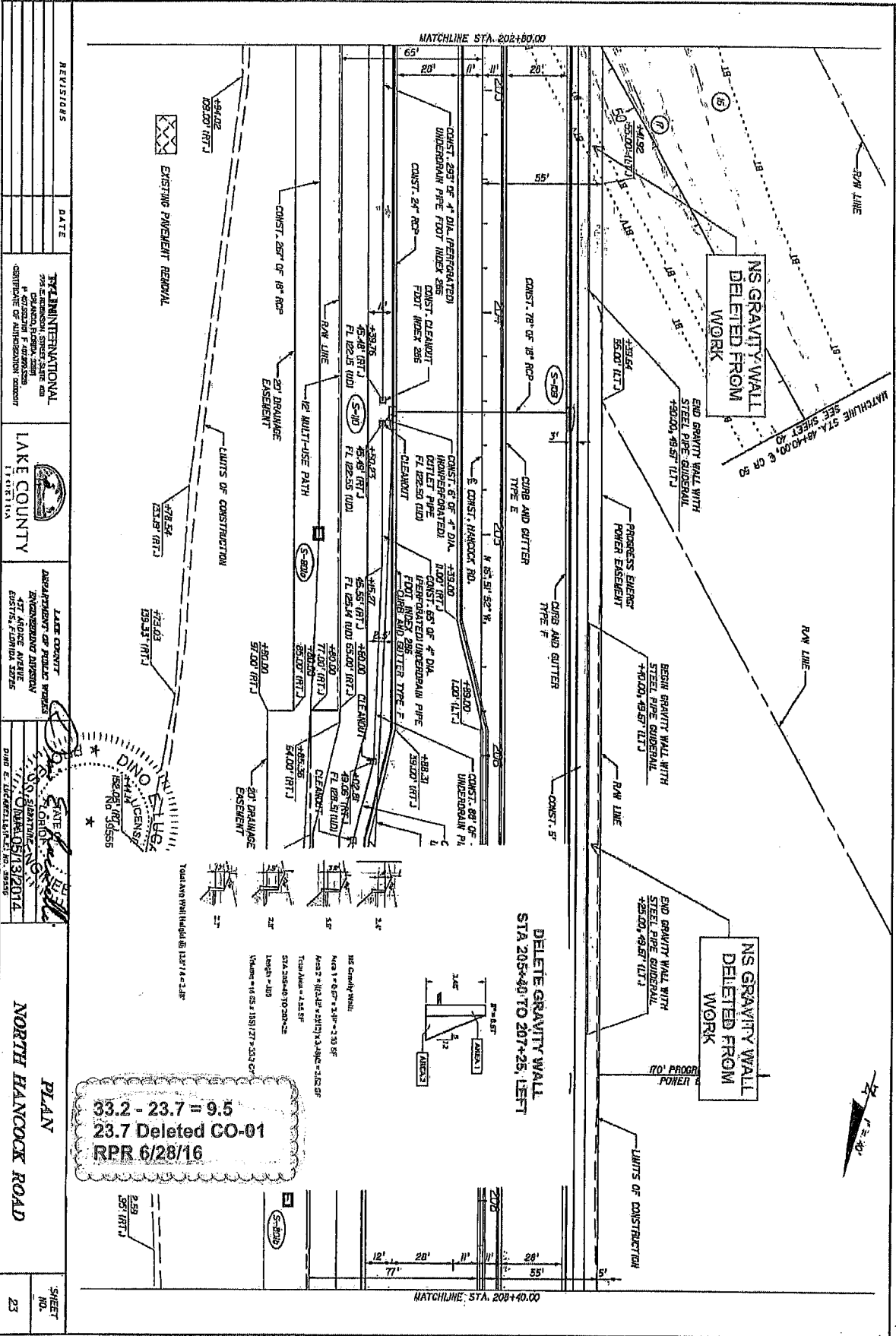

REVISIONS

NO.	DATE	DESCRIPTION

TRIUMPH INTERNATIONAL
 2700 W. WASHINGTON AVE.
 # 475000000
 DISTRICT OF COLUMBIA, DISTRICT

LAKE COUNTY
 DEPARTMENT OF PUBLIC WORKS
 INDEPENDENCE AVENUE
 # 475000000
 EAST ST. LOUIS, ILLINOIS 62206

PLAN
 NORTH HANCOCK ROAD
 SHEET NO. 23

CO-03 Deduct Wall

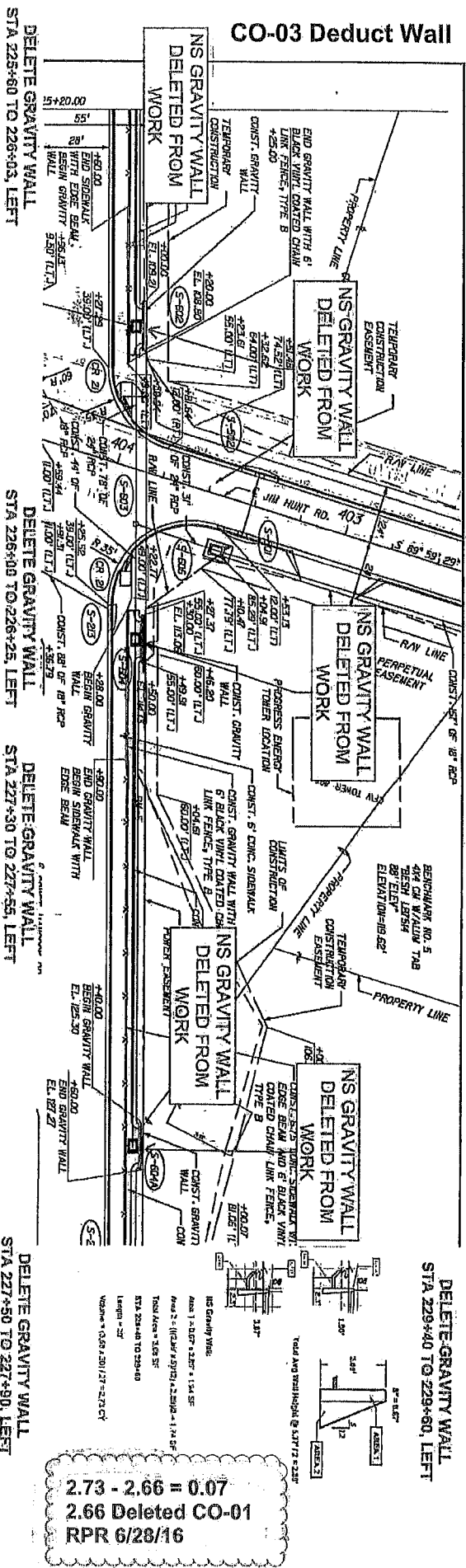

1.48 - 1.06 = 0.42
1.06 Deleted CO-01
RPR 6/28/16

1.8 - 1.4 = 0.4
1.4 Deleted CO-01
RPR 6/28/16

2.73 - 2.66 = 0.07
2.66 Deleted CO-01
RPR 6/28/16

7.26 CY

NS Gravity Wall
 Area 1 = 0.67' x 3.56' = 2.37 SF
 Area 2 = (0.53' x 3.56') + (3.56' x 2.34) SF
 Total Area = 4.02 SF
 STA 225+60 TO 226+03
 Length = 43'
 Volume = 0.68 x 43' = 29.14 CY

NS Gravity Wall
 Area 1 = 0.87' x 1.07' = 0.93 SF
 Area 2 = (0.14' x 1.07') + (1.07' x 1.31) SF
 Total Area = 1.61 SF
 STA 226+06 TO 226+25
 Length = 19'
 Volume = 1.03 x 19' = 19.57 CY

NS Gravity Wall
 Area 1 = 0.67' x 1.87' = 1.25 SF
 Area 2 = 0.14' x 1.87' + 1.87' x 1.51 SF
 Total Area = 2.71 SF
 STA 227+00 TO 227+35
 Length = 35'
 Volume = 1.94 x 35' = 67.90 CY

NS Gravity Wall
 Area 1 = 0.67' x 3.56' = 2.37 SF
 Area 2 = (0.53' x 3.56') + (3.56' x 4.53) SF
 Total Area = 6.94 SF
 STA 227+40 TO 227+90
 Length = 50'
 Volume = (0.53 x 50') + (4.53 x 50') = 250.00 CY

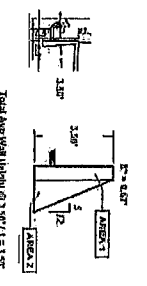
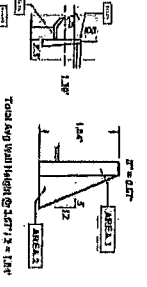
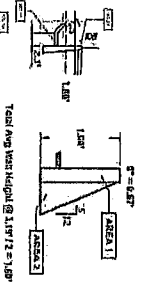
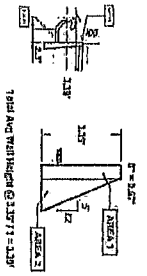

REVISORS	DATE	PLANNING INTERNATIONAL	LAKE COUNTY	LAKE COUNTY DEPARTMENT OF PUBLIC WORKS	STATE OF FLORIDA	PLAN	SHEET NO.
		700 S. UNIVERSITY AVENUE SUITE 400 CORONA FLORIDA 32004 CORPORATE OR ADMINISTRATIVE DIVISION	1100 N. FLA.	437 ANDRUE AVENUE ESTER, FLORIDA 32726	1717 CHANCELLER BLVD. SUITE 200 TALLAHASSEE, FLORIDA 32304	NORTH HANCOCK ROAD	27

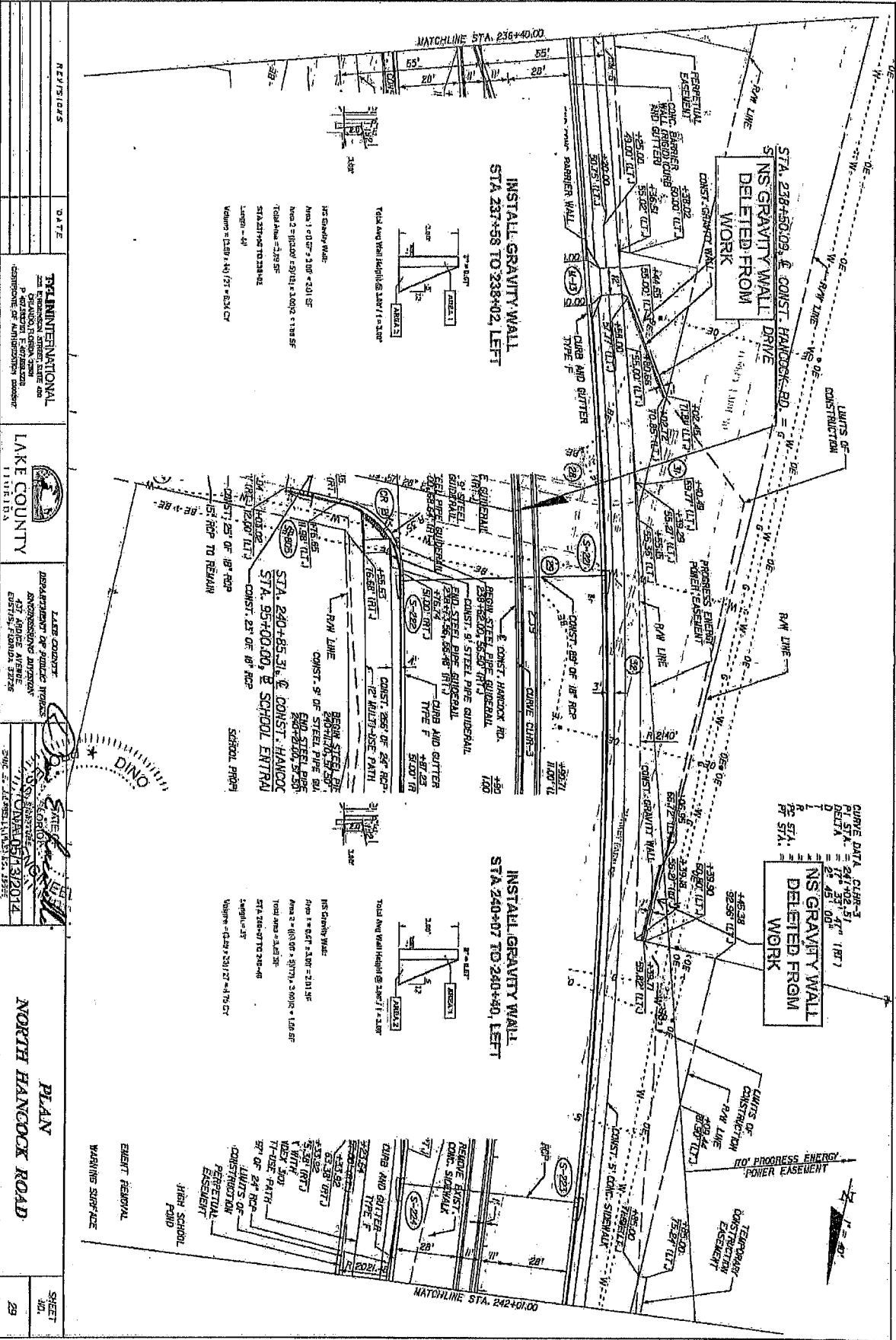

STA. 238+50.00, & CONST. HANCOCK RD. =
~~NS GRAVITY WALL~~
~~DELETED FROM~~
~~WORK~~

INSTALL GRAVITY WALL
 STA 237+58 TO 238+02, LEFT

CURVE DATA CURVE-3
 PI STA. = 241+02.51
 DELTA = 72° 31' 47" (RT)
 R = 451.00'
 PC STA. = 239+00.00
 PT STA. = 243+05.02

INSTALL GRAVITY WALL
~~DELETED FROM~~
~~WORK~~

INSTALL GRAVITY WALL
 STA 240+07 TO 240+40, LEFT

1/2" GRAVITY WALL
 Area 1 = 61.07' x 2.00' = 122.14 SF
 Area 2 = 11.00' x 2.00' = 22.00 SF
 Total Area = 144.14 SF
 STA. 237+58 TO 238+02
 Length = 34'
 Volume = 144.14' x 2.00' = 288.28 CY

1/2" GRAVITY WALL
 Area 1 = 64.07' x 2.00' = 128.14 SF
 Area 2 = 11.00' x 2.00' = 22.00 SF
 Total Area = 150.14 SF
 STA. 240+07 TO 240+40
 Length = 33'
 Volume = 150.14' x 2.00' = 300.28 CY

REVISIONS

NO.	DATE	DESCRIPTION

TECHNICAL INTERNATIONAL
 200 S. UNIVERSITY BLVD.
 SUITE 200
 TAMPA, FLORIDA 33606
 (813) 287-1111

LAKE COUNTY
 DEPARTMENT OF PUBLIC WORKS
 ANTI-CORRUPTION DIVISION
 431 ALICE AVENUE
 GUSTAVIA, FLORIDA 32726

STATE OF FLORIDA
 DEPARTMENT OF TRANSPORTATION
 DIVISION OF HIGHWAYS
 TALLAHASSEE, FLORIDA 32310

PLAN
 NORTH HANCOCK ROAD

SHEET
 29

CO-03 Adjustment CO-01 Calculation

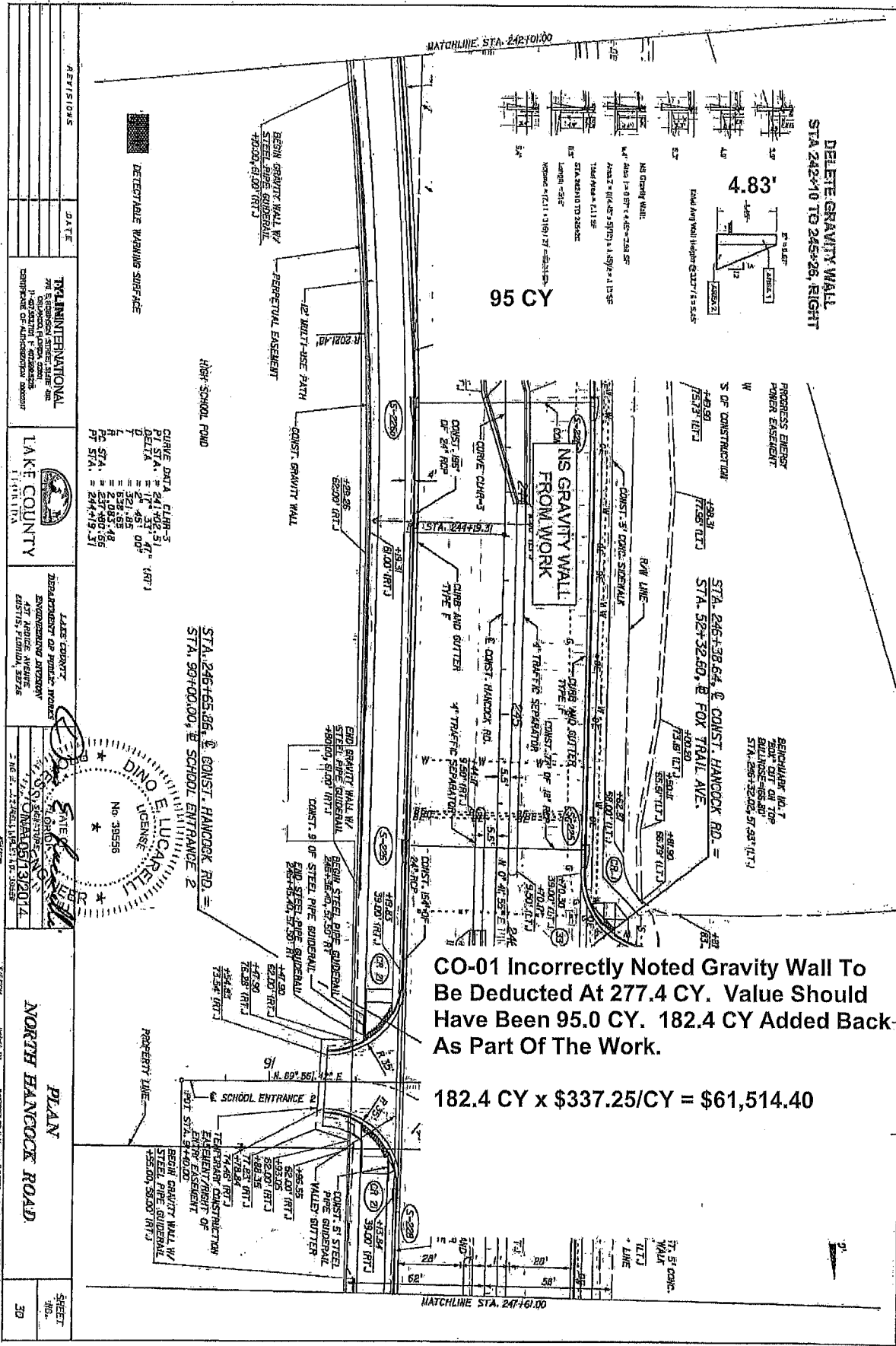

CO-01 Incorrectly Noted Gravity Wall To Be Deducted At 277.4 CY. Value Should Have Been 95.0 CY. 182.4 CY Added Back As Part Of The Work.

$182.4 \text{ CY} \times \$337.25/\text{CY} = \$61,514.40$

REVISIONS	DATE	DESCRIPTION

TRAIL INTERNATIONAL
 PROFESSIONAL ENGINEERING
 1100 S. UNIVERSITY AVENUE
 SUITE 200
 TAMPA, FLORIDA 33606

LAKE COUNTY
 DEPARTMENT OF PUBLIC WORKS
 ENGINEERING DIVISION
 407 AIRSIDE AVENUE
 GULFSTREAM, FLORIDA 33736

PLAN NORTH HANCOCK ROAD

SHEET NO. 30

QUANTITY DATA
 QTY = 95.00
 DELTA = 17.43
 L = 321.45
 H = 2.00
 PC STA. = 247+80.66
 PT STA. = 244+19.31

PERMITS
 DINO E. LUCARELLI
 No. 38556

CONTRACT
 STA. 245+38.64 @ CONST. HANCOCK RD. =
 STA. 90+00.00 @ SCHOOL ENTRANCE 2

PROPERTY LINE
 SCHOOL ENTRANCE 2

CO-03 Deduct Wall

Math Correction 6/28/16
RPR

CO-03 Deduct Wall Quantities

198+80 to 203+90	91.60 cy	107.10 CY
205+40 to 207+25	33.20 cy	33.20 Deleted CO-01 9.5 CY
225+60 to 226+03	7.42 cy	7.42 CY
226+00 to 226+25	7.42 cy	1.48 - 1.06 = 0.42 1.08 Deleted CO-01 0.42 CY
227+30 to 227+55	7.80 cy	1.8 - 1.4 = 0.4 1.4 Deleted CO-01 0.40 CY
227+50 to 227+90	10.26 cy	7.26 CY
229+40 to 229+60	2.73 cy	2.73 - 2.66 = 0.07 2.66 Deleted CO-01 0.07 CY
237+58 to 238+02	6.34 cy	6.34 CY
240+07 to 240+40	4.75 cy	4.75 CY
252+92 to 253+05	3.34 cy	3.34 CY
162.94 cy		(146.6 CY)
(-175.42 CY)		

Added Old 50 West Gravity Wall **2.88 CY**

Subtotal Wall Deduct CO-03 **(143.72 CY)**

Subtotal Wall Deduct CO-03 Cost 1 **(\$48,469.57)**

GUIDERAIL QUANTITY:

STA 198+40 to STA 198+80, LT	=	(40 LF)
STA 198+80 to STA 203+90, LT	=	(510 LF)
STA 252+70 to STA 252+80, RT	=	(10 LF)
STA 252+92 to STA 253+05, RT	=	(13 LF)
QUANTITY	=	(573 LF)
SUBTOTAL		
(573 LF) x \$55.00/LF	=	(\$31,515.00)

NS CONCRETE GRAVITY WALL:

STA 198+80 to STA 203+90, LT	=	(107.10 CY)
STA 205+40 to STA 207+25, LT	=	(9.50 CY)
STA 225+60 to STA 226+03, LT	=	(7.42 CY)
STA 226+00 to STA 226+25, LT	=	(0.42 CY)
STA 227+30 to STA 227+55, LT	=	(0.40 CY)
STA 225+50 to STA 227+90, LT	=	(7.26 CY)
STA 229+40 to STA 229+60, LT	=	(0.07 CY)
STA 237+58 to STA 238+02, LT	=	(6.34 CY)
STA 240+07 to STA 240+40, LT	=	(4.75 CY)
STA 252+92 to STA 253+05, RT	=	(3.34 CY)
STA 40+30 to STA 40+40, RT	=	2.88 CY
QUANTITY	=	(143.72 CY)
SUBTOTAL		
(143.72 CY) x \$337.25/CY	=	(\$48,469.57)

CO-01 WALL CORRECTION:

By CO-01 gravity wall from STA 242+10 to STA 245+80, RT was incorrectly deleted at (277.4 CY). Actual quantity of wall has been re-calculated at (95.0 CY). Correction of 182.4 CY to be added back into work.

SUBTOTAL		
182.4 CY x \$337.25/CY	=	\$61,514.40

TOTAL:
\$61,514.40 + (\$48,469.57) + (\$31,515.00) = (\$18,470.17)

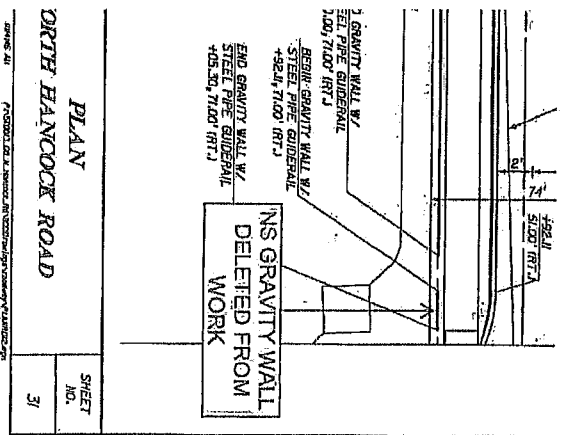

NS Gravity Wall Scheme 2:
Area 1 = 41.87' x 2.5' = 104.68 SF
Area 2 = 41.87' x 3.125' = 130.85 SF
Total Area = 235.53 SF
STA 252+92 TO 253+05
Length = 15'
Volume = (104.68 + 130.85) / 2 x 15' = 315.225 CY
315.225 CY x 55.00 \$/CY = \$17,337.38
NS Gravity Wall Scheme 2 Deleted Amount = 17,337.38

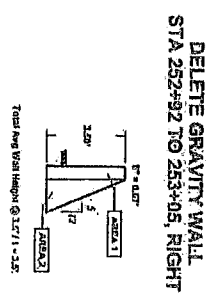

CO-03-06 BACKUP



POSPIECH
— CONTRACTING —

June 9, 2016

Hancock Road Phase III A and IIIB

FDOT ADA Ramp Modifications: Due to steep profile slope of the Trail ramps had to be extended to conform to FDOT ADA construction requirements. Plans indicated ramp width from 10' to 11.5'. To match trail width ramps were constructed at typical 12' width. Required adjustments increased trail ramp 4" concrete quantity and Detectable Warning Surface (DWS) quantity. Additionally, two (2) each DWS's not shown for installation at the median safe haven by the original bid plans are included as part of this item CO-03-06.

The Contractor proposed this modification to the Work at a cost increase of \$4,913.18 and no change to Contract Duration (see attached proposal marked Exhibit 6). Pospiech Contracting, Inc. provided cost data and quantities listed his proposal.

Thank You,

Gary Bracken

Cost Breakdown:

Measured Old 50 East West Trail Curb Ramp 4" Concrete Sidewalk Quantity at 154.8 SY. Calculated Trail Curb Ramp 4" Concrete Quantity at 69.4 SY. Overrun 4" concrete quantity at 85.4 SY. Unit Cost at \$28.50/SY.

Cost Increase at \$2,433.90.

All Remaining Measured Trail Curb Ramp 4" Concrete Sidewalk at 5,198.7 SY. Calculated Trail Curb Ramp 4" Concrete Quantity at 5,052.9 SY. Increase 4" Concrete Sidewalk 145.8 SY. Unit cost for 4" sidewalk is offset by asphalt trail unit costs. $\$28.50/\text{SY} - \$19.28/\text{SY} = \$9.22/\text{SY}$.

Cost Increase at $145.8 \text{ SY} \times \$9.22/\text{SY} = \$1,344.28$.

Measured DWS at 357.4 LF. Calculated DWS at 354.6 LF. Increase at 2.8 LF or 5.6 SF. Average DWS at 21 SF. $5.6 \text{ SF} / 21 \text{ SF} = 0.27 \text{ DWS}$. Unit Cost per part A of contract at \$500.00/DWS.

Increase Cost Measured Length DWS at $0.27 \times \$500.00 = \135.00 .

Added Two (2) DWS's at School Main Pedestrian Crossing not shown for installation by the original plans. Unit cost of DWS per part A of the contract is at \$500.00/EA.

Increase work 2 DWS $\times \$500.00/\text{DWS} = \$1,000.00$.

Total ADA Ramps Modification Cost at \$4,913.18.

EXHIBIT 6 BACKUP DOCUMENT

Page 1 of 2

N Hancock Rd

Trail Ramp Measurements

By: RPRudd; Terry, Inc

Date: 05/17/2016

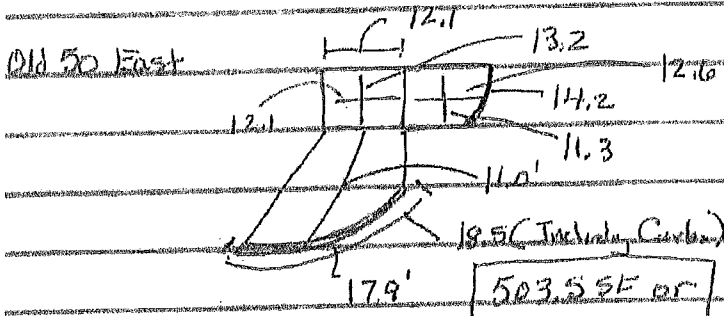

503.5 SF or
559 SF

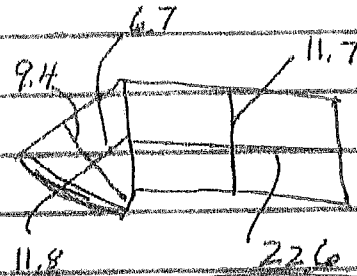

$264.4 + 68.0 = 327.4$ SF
36.4 SF

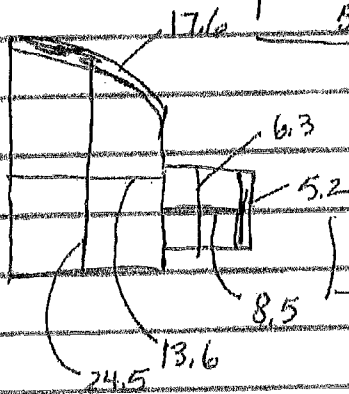

386.8 SF or 43.0 SF

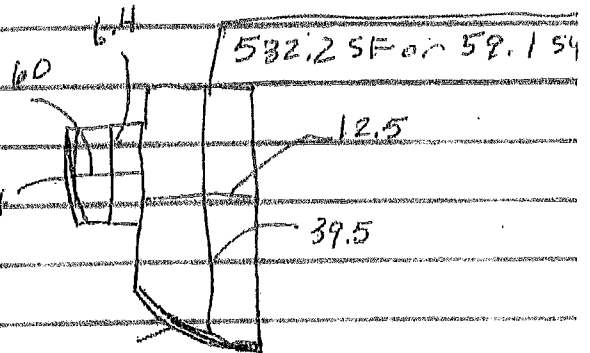

532.2 SF or 58.1 SF

Old 50 West

567.8 SF or 63.1 SF

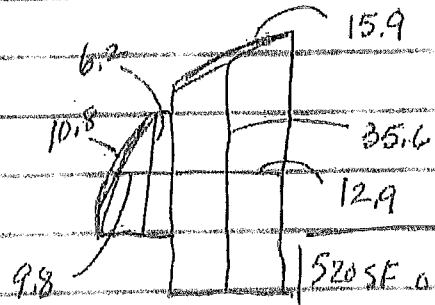
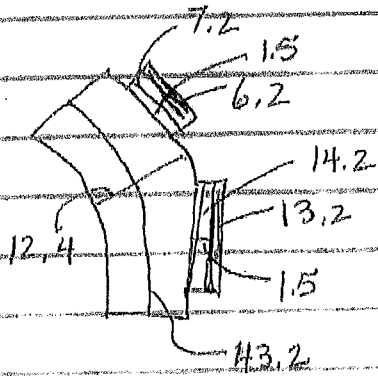

520 SF or 57.8 SF

N. Hancock Rd

Page 2 of 2

Trail Ramp Measurements

By: RPR/djd; Tierra, Inc.

Date: 05/17/2016

Jim Huot

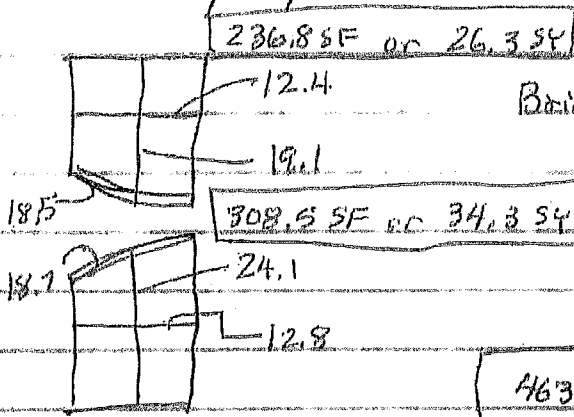

Bridge

279.4 SF or 31.0 SY

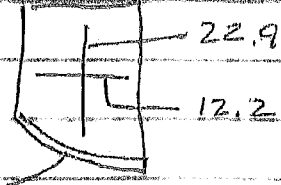

17.8

18.6

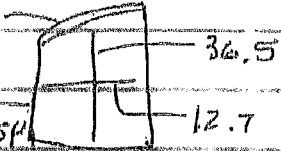

463.6 SF or 51.5 SY

Big Sky

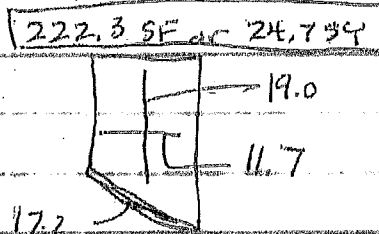

17.2

11.8

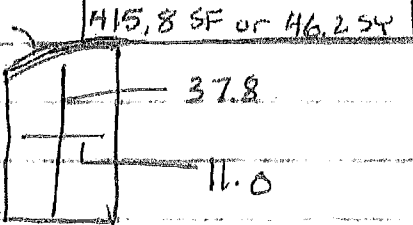

Bus Entrance

282.5 SF or 31.4 SY

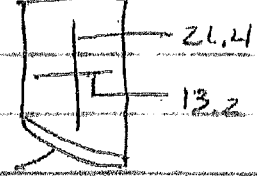

20.3

239.3 SF or 26.6 SY



School Main Entrance

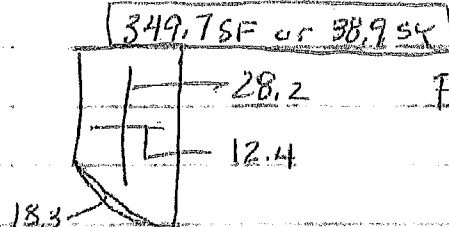

18.3

19.0

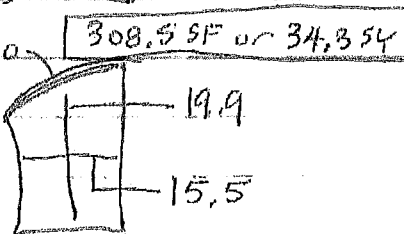

Fasgate

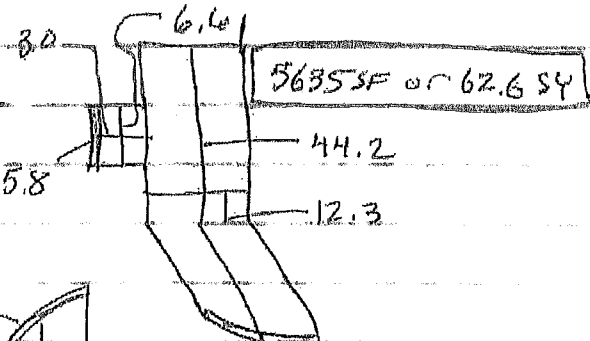

20.9

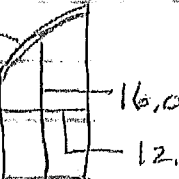

192 SF or 21.3 SY

Trail Structure

Bid A

12" Stab \$3.35/SY
 6" Limerock \$9.10/SY
 1.5" SP 12.5 \$8.68/SY

Bid B

12" Stab \$4.10/SY
 6" Limerock \$8.35/SY
 1.5" SP 12.5 \$8.70/SY

4" Concrete Sidewalk = \$28.50/SY ————— \$29.60/SY
 DWS \$500.00/EA ————— \$425.00/EA

Plan

Placed

1/2 So East	Sidewalk Plan	DWS	Sidewalk	DWS
NE	457.6 SF	7.5 LF	327.4 SF	11.8 LF
NW	315.9 SF	23.7 LF	503.5 SF	32.1 LF
SW	309.8 SF	28.9 LF	386.8 SF	22.8 LF

1/2 So West

NE	201.1 SF	15.7 LF	532.2 SF	22.8 LF
SW SE	212.6 SF	23.8 LF	520 SF	26.7 LF
SW	1222 SF	18.1 LF	567.8 SF	19.4 LF

Jim Hunt

SE	157.8 SF	15.9 LF	236.8 SF	18.5 LF
NE	157.6 SF	16.7 LF	308.5 SF	18.7 LF

Bridges

SE	157.0 SF	16.0 LF	463.6 SF	17.8 LF
NE	157.0 SF	16.1 LF	274.4 SF	18.6 LF

TA 234, Rt

SE	181.6 SF	19.6 LF		
NW	182.1 SF	19.6 LF		

Not Constructed

gr Totals	3712.1 SF	221.6	4,126.0 SF	209.2 LF
-----------	-----------	-------	------------	----------

	Plan		Placed	
Big Store	Sidewalk	DWS	Sidewalk	DWS
SE	118 SF	12.8 LF	415.8 SF	11.8 LF
NE	157.6 SF	17.0 LF	222.3 SF	17.2 LF
Bus Entrance	Ø			
SE	185.4 SF	19.4 LF	239.3 SF	20.3 LF
NE	132.3 SF	14.0 LF	282.5 SF	19.9 LF
School Meeting				
SE	217.7 SF	16.5 LF	308.5 SF 349.7 SF	19.0 LF
NE	196.9 SF	16.7 LF	349.7 SF	18.3 LF
Escalator				
SE	183.1 SF	19.1 LF	192 SF	20.4 LF
NE	221.3 SF	17.5 LF	563.5 SF	20.8 LF
<hr/>				
Page Totals	1410.3 SF	133.0 LF	2,573.6 SF	148.2 LF
Page 1	3,712.1 SF	221.6 LF	4,126.0 SF	209.2 LF

Plan	Plan	Placed	Placed
5,122.4 SF	354.6 LF	6,699.6 SF	357.4 LF

Trail Sidewalk = $6,699.6 - 5,122.4 = 1,577.2$ 30.8% Greater Than Planned.
 DWS = $357.4 - 354.6 = 2.8$ 0.8% Greater Than Planned.

$$1,577.2 \text{ SF} = 175.24 \text{ SY} @ \$9.22/\text{SY} = \$1,615.71$$

$$2.8 \text{ LF} = 5.6 \text{ SF DWS} @ \$500/\text{EA}$$

Average DWS @ 20+ SF Page 30% of \$500 =

$$\$1,765.72$$

For Increase In 4" Sidewalk There Would
Be An Equal Decrease In Asphalt Trail Items.

Taking Longer of Bid A/B for 4" Sidewalk
Unit Value @ \$29.60/SY

Taking Lower of Bid A/B for Asphalt Trail
Items Unit Value (Sum) @ \$20.38/SY

Difference Between Trail Types @

$$\$29.60 - \$20.38 = \$9.22/SY$$

Addition Concrete Trail Added @ 175.24 SY

$$175.24 SY \times \$9.22/SY = \$1,615.71$$

DWS Per Each w/ Avg @ 21 SF Per Bid A

$$5.6 SF (overrun) / 21 SF = 0.27 DWS$$

$$0.27 DWS \times \$500/EA DWS = \$135.00$$

I get total Overrun Cost for Trail
Ramp Size Increase @ \$1,750.71

$$\boxed{+ \$1,750.71}$$

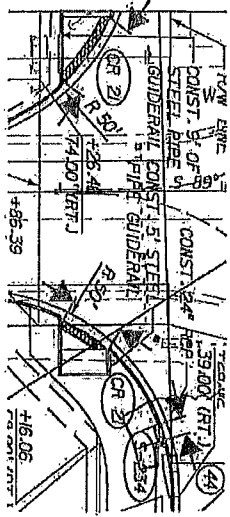
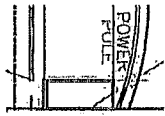
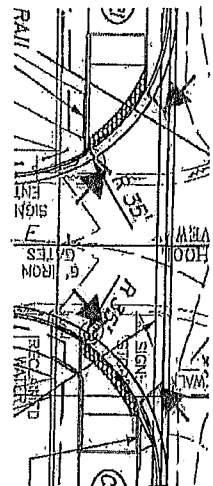
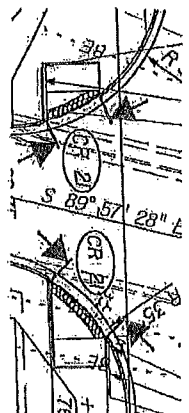
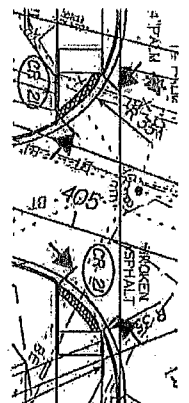
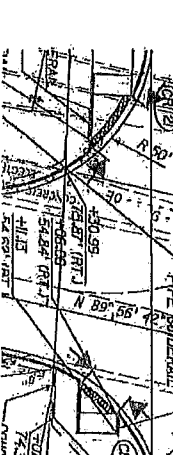
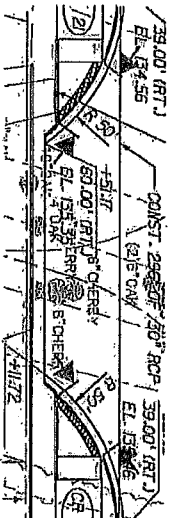
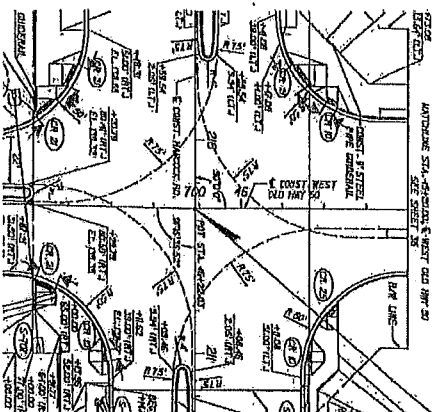
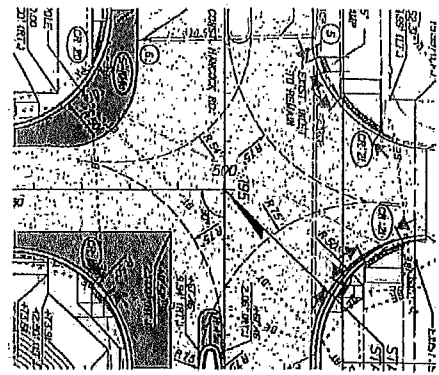

Estimated Plan Quantities:
 4" Sidewalk at 5,122.4 SY;
 DWS at 354.6 LF or 709.2 SF

Robert Rudd

From: Robert Rudd
 Sent: Thursday, May 19, 2016 4:27 PM
 To: gisider@postofficecontracting.com
 rrudd@ad.com
 CC: Subject: N Hancock Rd, CO-49 Trail Ramps
 Attachments: Newscraft_Plan_16c_Sheep.pdf

gary,

See attached Trail Ramps measurements and notes.

Old 50 East West Ramps are the only locations where there is no asphalt offset related to additional concrete for ramps. I get increases in concrete at these ramps at 85.4 SY. This quantity includes NW ramp construction twice. Bid A unit cost is at \$28.50/SY. Increase in cost is at \$2,493.90.

Total quantity for all other trail ramps is at 145.8 SY. At these locations when concrete increases asphalt trail decreases by the same value. I get the offset cost at a total \$9,227.57 using lowest available unit costs for asphalt and biggest available unit cost for concrete. Cost increase totals out to be \$1,942.26.

Detachable Warning Measurements for installed vs Plan are almost the same. I measured 357.4 LF of installed DWS at trail ramps. Plan estimated DWS at trail ramps is at 354.6 LF. Only a 2.8 LF or 5.9 SF difference. Since ramps are per each with the average ramp at 21 SF (bid B) to 25 SF (bid B) each increase using small ramp averages would be at around \$133.00.

There are three curb ramps that were shown with no DWS. All in Bid A area at \$500.00/EA. There were two ramps / DWS's not installed at STA. 2944+ Right. The actual plan number of DWS's in Bid A was 32. Estimated 34. Plan and Bid B at 60 DWS's. Concrete was not there to measure so I adjusted myself with them. There are 42 DWS's rather than 40. Add 2 DWS's at \$200.00/EA for a total cost of \$1,000.00.

I get total Trail Ramps Cost Change at \$4,513.18.
 Take a look and let me know what you think.

Thanks,
 Robert Rudd
 Triang, Inc.

CO-03-07 BACKUP



June 9, 2016 (Revised 06/16/2016)

Hancock Road Phase IIIA and IIIB

Robert Rydd,

Please see the attached Change order Request COR13 for the full depth construction of Hancock Road North of the Gatewood Intersection. Original plans show a mill and resurface in this area. The Total Price of this Change is \$49,325.36.

Thank You,

Gary Bracken

Math Corrections 06/16/16
RPR

5-4-2016 North of Gatewood Reconstructinn vs Mill & overlay

Install Concrete Sidewalk Per Attached Plan:
98.44 SY @ 28.50 = Add + 2,805.54

Milling Credit Replaced with full depth Construction
1532.44 SY @ line Item 11 phasse IIB 2.50 x 1532.44
(-3,831.10)

Frictloin Course- N/A included in Paving 0,00

Cut Subgrade 1532.44 SY line Item 7 @ 4.10
1532.44x 4.10 = 6281.20

Umerock Item # 8 @ 11.50 x 1532.44SY
Price 17,623.06

Item 10 - 2 1/2 Asphalt Base @11.20
1532.44 x 11.20 Price 17,163.33

Item 12 Prime and Sand @.40
1532.44 x .40 Price 612.98

Tack Coat Item 13, 1532.44 x .35 536.35

Reclamer for 1 Day Rental
(See Attached Invoice) \$8,134.00

Total for Full Depth Construction COR13 \$49,325.36

POSPIECH CONTRACTING, INC.

16569

Invoice #	Invoice Date	Invoice Amount	Invoice #	Invoice Date	Invoice Amount
13R001997506	Feb 09/16	8,134.00			

RING: Ring Power Corporation Check: 016569 Mar 25/16 Total: 8,134.00

PRODUCT DLT147 USE WITH 81600 ENVELOPE Deluxe For Business 1-800-225-6980 or www.nebe.com

PRINTED IN U.S.A.

CUSTOMER CONTACT: MICK

6100

THIS INVOICE IS NET DUE UPON RECEIPT
EQUIPMENT RENTAL FROM 02/01/16 THRU 02/03/16
CATERPILLAR MODEL RM500
RM500

1.0 ASW00495
ASW00495

ID NO: ASW00495 SERIAL NO: ASW00495
PIN: *CATRM500TASW00495*

7500.00

USED CATERPILLAR RM-500 ROTARY MIXER, TIER 3
ENV FEE

150.00

FOR YOUR CONVENIENCE THIS UNIT WAS SHIPPED WITH
A FULL FUEL TANK AND MUST BE RETURNED FULL OR A
FUEL FEE WILL BE CHARGED FOR ALL FUEL ADDED.
.....THANK YOU FOR YOUR COOPERATION.....

RECEIVED

FEB 16 2016

RING POWER IS PROUD TO ANNOUNCE INVOICES AND
ACCOUNT STATEMENTS AVAILABLE ONLINE!
FOR INFORMATION ON RING POWER'S WEBSITE ACCOUNT
ACCESS VISIT [HTTP://WWW.RINGPOWER.COM/WEB-INVOICE](http://www.ringpower.com/web-invoice)

FLA STATE SALES TAX 459.00
FLA ST JOHNS SURTAX 25.00

A SERVICE CHARGE OF 1 1/2 % PER MONTH WILL BE CHARGED ON PAST DUE ACCOUNTS.

Remit to:
Ring Power Corporation
PO Box 935004
Atlanta, GA
31193-5004

8134.00

Title to the equipment listed hereon shall not pass to the purchaser until the purchase price (including all taxes) has been paid, but such title remain vested in the seller until all sums due or become due from the purchaser to the seller thereon, whether evidenced by note, book account, judgment, or otherwise, shall have been fully paid, at which time ownership shall pass to the purchaser. Purchaser shall assume all liability of damage or destruction to same. At any time after any payment thereon becomes overdue seller may avail himself of any legal remedy including the right to repossess the equipment without notice and purchaser agrees to pay legal fees.
CATIN27/00

ORIGINA

Ring Power



Ring Power Corporation
 14300 Hedge Dalean Blvd
 Brooksville, FL 34601
 (352) 796-4978

Sign up for Online Invoice Access
www.ringpower.com/web-invoice

RING POWER CORPORATION 500 WARD COMMERCE PKWY, ST AUGUSTINE, FL 32087 (904) 737-7730

INVOICE

S POSPIECH CONTRACTING INC
O 201 S APOPKA AVE
L
D INVERNESS FL
T
O

34452-4802

S CUSTOMER PICK UP IN WCC
H 9800 JASMINE AVE
I
P
T TAMPA, FL
O HILLSBOROUGH - 29

INVOICE NUMBER	INVOICE DATE	SERVICE	DATE SHIPPED	CUSTOMER FEE	ACCOUNT NUMBER	TAX
13RC01997506	02-09-16	CUSTOMER PICKUP	02-03-16	VERBAL MICK FEE	005751	1
QUANTITY	I.D.# & SERIAL#	DESCRIPTION			AMOUNT	

6988
(Handwritten circled number)

CUSTOMER CONTACT: MICK

THIS INVOICE IS NET DUE UPON RECEIPT
 EQUIPMENT RENTAL FROM 02/01/16 THRU 02/03/16
 CATERPILLAR MODEL RM500
 RM500

1.0 ASW00495
 ASW00495

ID NO: ASW00495 SERIAL NO: ASW00495
 PTN: *CATRM500TASW00495*

7500.00

USED CATERPILLAR RM-500 ROTARY MIXER, TIER 3
 ENV FEE

150.00

FOR YOUR CONVENIENCE THIS UNIT WAS SHIPPED WITH
 A FULL FUEL TANK AND MUST BE RETURNED FULL OR A
 FUEL FEE WILL BE CHARGED FOR ALL FUEL ADDED.
THANK YOU FOR YOUR COOPERATION.....

RECEIVED

FEB 10 2016

RING POWER IS PROUD TO ANNOUNCE INVOICES AND
 ACCOUNT STATEMENTS AVAILABLE ONLINE!
 FOR INFORMATION ON RING POWER'S WEBSITE ACCOUNT
 ACCESS VISIT [HTTP://WWW.RINGPOWER.COM/WEB-INVOICE](http://www.ringpower.com/web-invoice)

FLA STATE SALES TAX

459.00

FLA ST JOHNS SURTAX

25.00

A SERVICE CHARGE OF 1 1/2 % PER MONTH WILL BE CHARGED ON PAST DUE ACCOUNTS.

Remit to:
 Ring Power Corporation
 PO Box 935004
 Atlanta, GA
 31193-5004

PAY AMOUNT
8134.00

Title to the equipment listed hereon shall not pass to the purchaser until the purchase price (including all taxes) has been paid, but such title remain vested in the seller until all sums due or become due from the purchaser to the seller thereon, whether evidenced by note, book account, judgment, or otherwise, shall have been fully paid, at which time ownership shall pass to the purchaser. Purchaser shall assume all liability of damage or destruction to same. At any time after any payment thereon becomes overdue seller may avail himself of any legal remedy including right to repossess the equipment without notice and purchaser agrees to pay legal fees.
 CAT1927/BB

ORIGINA

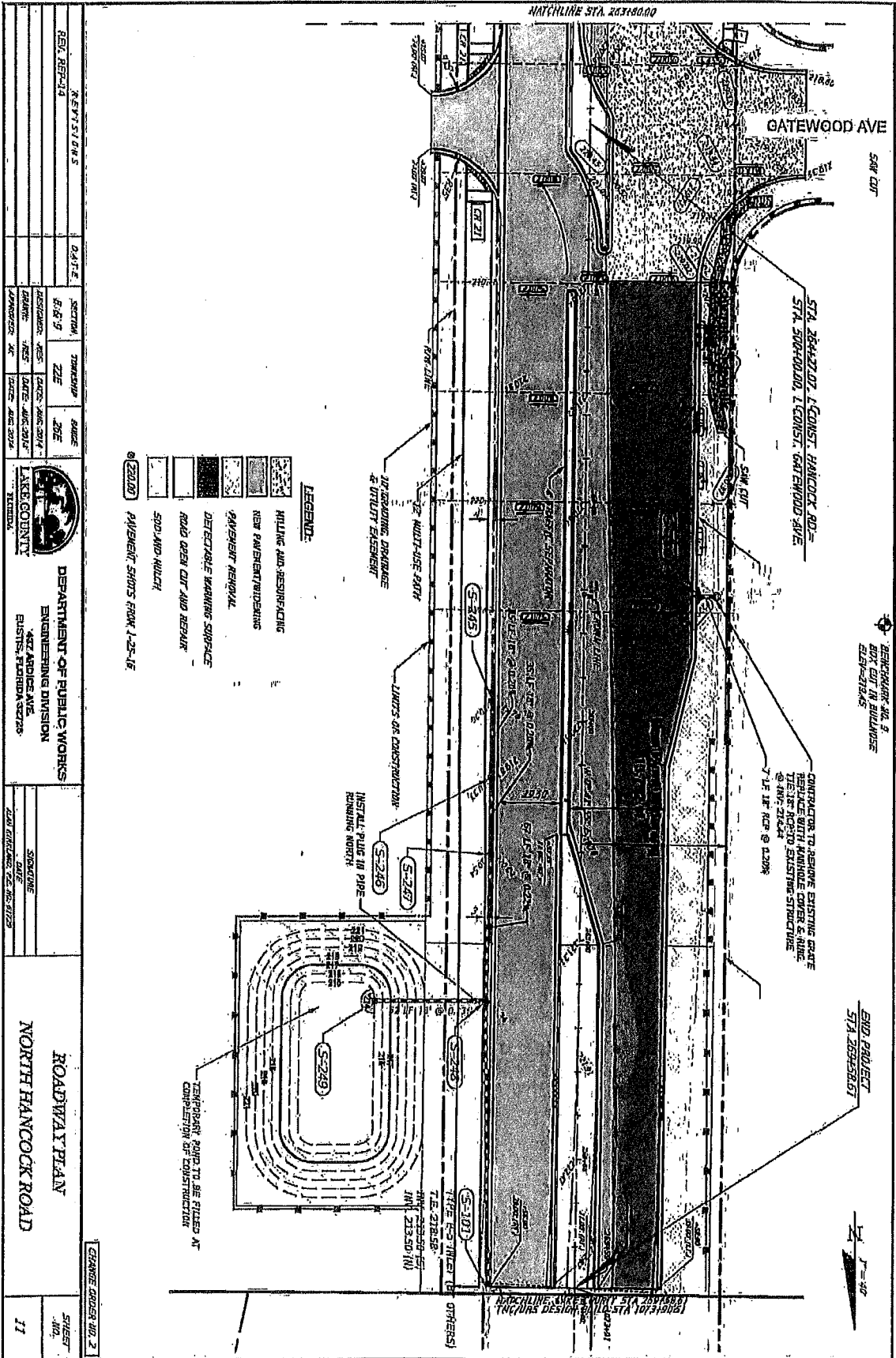

GATEWOOD AVE

STA 264+27.07, 1.60 CONST. HANCOCK RD- STA 269+00.00, 1.60 CONST. GATEWOOD AVE

CONTRACTOR TO REMOVE EXISTING ROAD MARKINGS WITH MINOR CUT AND REPAIR TO THE EXISTING STRUCTURE

END PROJECT STA 269+58.67

PAVEMENT SHOOTS FROM 1-25-1E

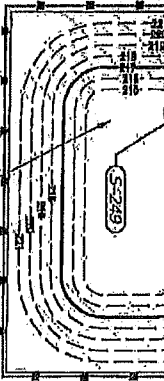

PAVEMENT SHOOTS FROM 1-25-1E

PAVEMENT SHOOTS FROM 1-25-1E

PAVEMENT SHOOTS FROM 1-25-1E

PAVEMENT SHOOTS FROM 1-25-1E

PAVEMENT SHOOTS FROM 1-25-1E

PAVEMENT SHOOTS FROM 1-25-1E

PAVEMENT SHOOTS FROM 1-25-1E

PAVEMENT SHOOTS FROM 1-25-1E

PAVEMENT SHOOTS FROM 1-25-1E

PAVEMENT SHOOTS FROM 1-25-1E

PAVEMENT SHOOTS FROM 1-25-1E

PAVEMENT SHOOTS FROM 1-25-1E

PAVEMENT SHOOTS FROM 1-25-1E

PAVEMENT SHOOTS FROM 1-25-1E

PAVEMENT SHOOTS FROM 1-25-1E

PAVEMENT SHOOTS FROM 1-25-1E

PAVEMENT SHOOTS FROM 1-25-1E

PAVEMENT SHOOTS FROM 1-25-1E

PAVEMENT SHOOTS FROM 1-25-1E

PAVEMENT SHOOTS FROM 1-25-1E

CO-03-08 BACKUP



June 9, 2016

Hancock Phase IIIA and III B

Robert Rudd,

Old 50 West and Gatewood Additional Survey: Additional contractor provided survey performed to: (1) Determine field conditions not indicated by the plans; and (2) Resurvey area at LCPW / Tierra provided revised elevations and grades.

Pospiech Contracting, Inc. proposed this modification to the Work at an increase cost of \$6,600.00 and no change to Contract Duration (see attached proposal marked Exhibit 8). Pospiech Contracting, Inc. provided cost data and quantities listed the proposal.

Thank You,

Gary Bracken

GradeWorks, LLC *C/12-03-08*
 SUBCONTRACTOR'S APPLICATION FOR PAYMENT

PCI Job No. _____
 PCI Job Name North Hancock Road Extension PH IIIA & IIIB

APPLICATION NO. 15
 APPLICATION DATE 02/20/10

A	B	C	D	E	F	G	H	I	J	K	L
ITEM NO.	DESCRIPTION OF WORK	QTY	UM	UNIT COST	SCHEDULED VALUE	TOTAL UNITS COMPLETED TO DATE	TOTAL VALUE COMPLETED TO DATE	UNITS COMPLETED FROM PREVIOUS APPL.	AMOUNT COMPLETED FROM PREVIOUS APPLICATION	MARK UP THIS PERIOD	AMOUNT THIS PERIOD
	BASE CONTRACT										
1	Survey and Asbulte, PH IIIA	1	LN	\$ 77,087.48	\$ 77,087.48	100.00	\$ 77,087.48	100.00	\$ 77,087.48	0.00	\$ -
2	Survey and Asbulte, PH IIIB	1	LN	\$ 16,412.52	\$ 16,412.52	0.77	\$ 12,662.52	0.00	\$ -	0.97	\$ 6,000.00
2	Survey and Asbulte, PH IIIA & IIIB	1	LN	\$ 1,500.00	\$ 1,500.00	0.00	\$ -	0.00	\$ -	0.00	\$ -
	TOTAL BASE CONTRACT				\$ 95,000.00		\$ 89,750.00		\$ 77,087.48		\$ 6,000.00
	CHANGE ORDERS										
1	Additional Survey Services - North of Gatewood				\$ 4,800.00		\$ 4,800.00				
2	Additional Survey Services - Turkey Farm & 50 W				\$ 1,200.00		\$ 1,200.00				
	Subtotal				\$ 6,000.00		\$ 6,000.00				
	TOTAL CHANGE ORDERS				\$ 6,000.00		\$ 6,000.00				
	TOTAL				\$ 101,000.00		\$ 95,750.00		\$ 83,087.48		\$ 6,000.00

Text Clarification 06/16/16
 RPR

Markup
 TOTAL 6,000.00
 Subtotal: \$6,000.00
 10% Markup: \$ 600.00
 Total: \$6,600.00

CO-03-08 ADDITIONAL SURVEY SERVICES

1. Additional Survey Services Required Due To 1' Plan Survey Error On N Hancock Rd at Gatewood Ave. Cost Before 10% Allowed Markup at \$4,800.00.
2. Additional Survey Services Required Due County Requested Pavement Slope Corrections at Old 50 West Near and At Turkey Farm Rd. Existing Roadway Elevations and Station and Offsets Obtained and Data was provided to LCPW / Tierra, Inc. for use. Cost Before 10% Allowed Markup at \$1,200.00.

$\$4,800.00 + \$1,200.00 = \$6,000.00$
 $\$6,000.00 \times 1.1 = \$6,600.00$

CO-03-08 ADDITIONAL SURVEY SERVICES COST = \$6,600.00

CO-03-09, 10, 11, 12 Backup



POSPIECH
— CONTRACTING —

June 9, 2016 (REVISED 06/16/16)

Hancock Road Phase IIIA and IIIB

Robert Rudd,

The following addresses origin plan adjustment required per County request to: (1) transition the roadway construction profile down 1' due to plan / survey error located at Gatewood Ave and (2) added work requested to coordinate project construction with the ongoing Turnpike Interchange Project. All items noted reflect field measured quantities at bid schedule of values costs.

CO-03-09: Plan Survey Correction Area: Plan Survey Area Error resulted in the removal and reconstruction of 200 LF of Type F Curb and Reconstruction of a 200' x 33' area of subgrade.

Pospiech Contracting, Inc. proposed this modification to the Work at an increase cost of \$5,768.70 and no change to Contract Duration (see attached proposal marked Exhibit 9). Pospiech Contracting Inc. provided cost data and quantities listed in the proposal...

CO-03-10: Due to roadway alignment shift of N Hancock Rd from Gatewood Ave to north project limits to conform too Turnpike construction alignment additional 24" RCP was required for installation.

Pospiech Contracting, Inc. proposed this modification to the Work at an increase cost of \$10,006.50 and no change to Contract Duration (see attached proposal marked Exhibit 9). Pospiech Contracting, Inc. provided cost data and quantities .

CO-03-11: Due to roadway alignment shift of N Hancock Rd from Gatewood Ave to north project limits to conform too Turnpike construction alignment additional 4" concrete sidewalk was required for installation.

Pospiech Contracting, Inc. proposed this modification to the Work at an increase cost of \$2,214.45 and no change to Contract Duration (see attached proposal marked Exhibit 9). Pospiech Contracting, Inc. provided cost data and quantities.

CO-03-12: Due to roadway alignment shift of N Hancock Rd from Gatewood Ave to north project limits to conform too Turnpike construction alignment additional storm system structures construction was required.

Pospiech Contracting, Inc. proposed this modification to the Work at an increase cost of \$4,825.00 and no change to Contract Duration (see attached proposal marked Exhibit 8). Pospiech Contracting, Inc. provided cost data and quantities.

Thank You,

Gary Bracken

COST DATA: CO-03-09 Additional Subgrade Grading North of Gatewood Ave. the Area is 200x 28 and 300x33 for a total SY of 1722SY @ 3.35 contract price unit Totals 5,768.70 total additional cost.

CO-03-10 Additional 210 LF of 24" pipe was added not included in the original plans North of Gatewood Ave. The contract amount per LF is 47.65 for a total amount of 10,006.50

CO-03-11 Includes an additional Sidewalk North of Gatewood per revised plans. The contract amount for 4" sidewalk is 28.50 per SY with an additional 77.7 SY installed for a Total of 2,214.45.

CO-03-12 Adds an additional Ditch Bottom Inlet at a contract price of 2,725.00 (line item # 42) and 2 modifications to existing Inlets all North of Gatewood Ave at a contract price of 1,050.00 EA (line item 46 Phase II) For a Total Cost of 4825.00

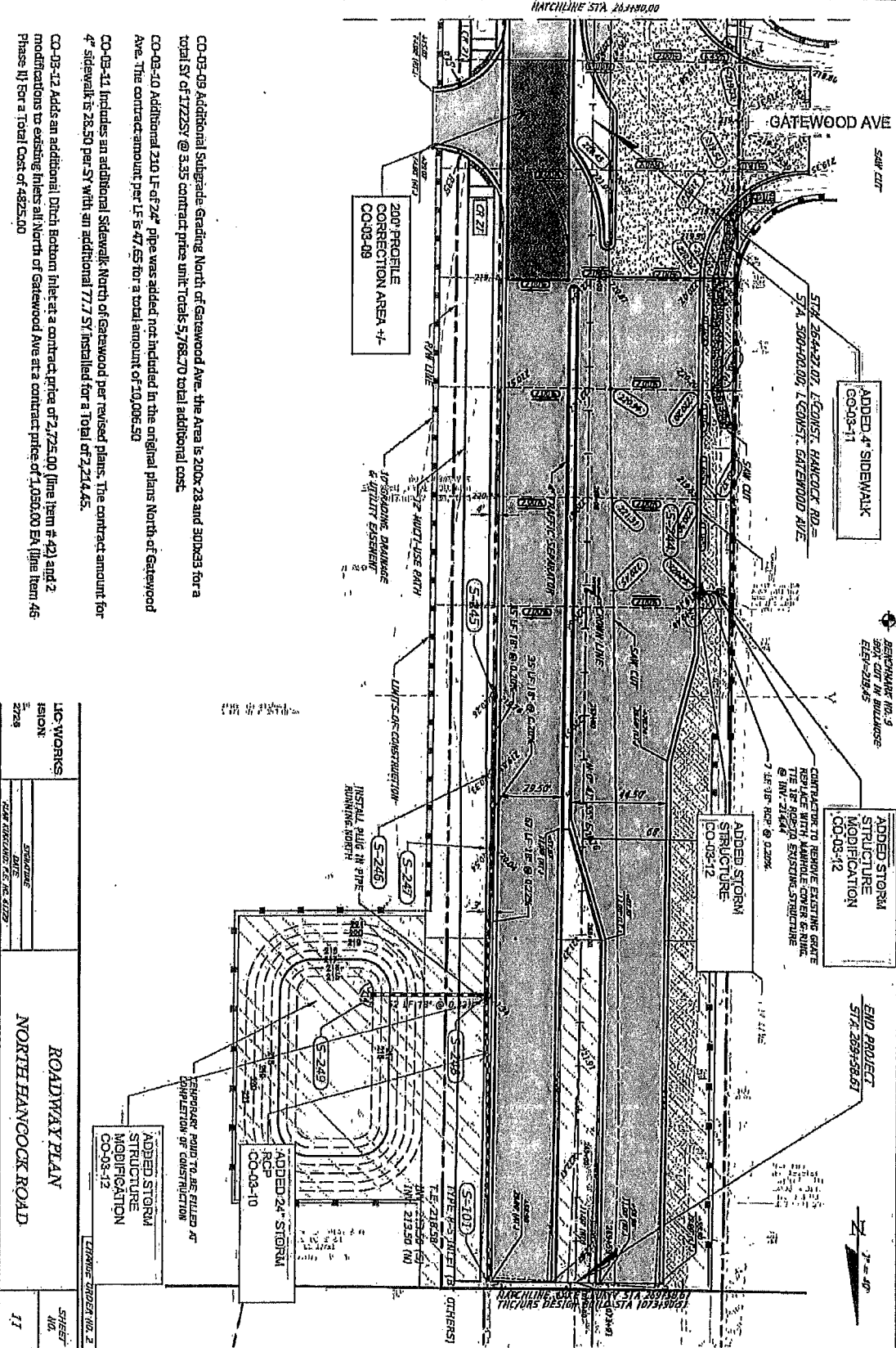

- CO-03-09 Additional Subgrade Grading North of Gatewood Ave. The Area is 200x28 and 300x33 for a total SY of 17225Y @ 3.35 contract price unit Totals \$5,768.70 total additional cost.
- CO-03-10 Additional 210 LF of 24" pipe was added not included in the original plans North of Gatewood Ave. The contract amount per LF is 47.65 for a total amount of 10,006.50
- CO-03-11 Includes an additional Sidewalk North of Gatewood per revised plans. The contract amount for 4" sidewalk is 28.50 per SY with an additional 77.7 SY installed for a Total of 2,214.45.
- CO-03-12 Adds an additional Ditch Bottom Inlet at a contract price of 2,725.00 (line item # 42) and 2 modifications to existing inlets all North of Gatewood Ave at a contract price of 1,050.00 EA (line item 46 Phase II) For a Total Cost of 4825.00

LIC WORKS REGION	DATE	2/28/88
	BY	SAF THORNTON, E. R. K. 2/28
ROADWAY PLAN NORTH HANCOCK ROAD		SHEET NO. 17

CO-03-13 BACKUP

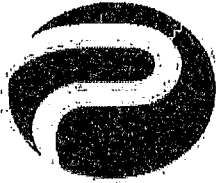

POSPIECH
— CONTRACTING —

June 23, 2016

North Hancock Road Extension Phase IIIA and IIIB
FPN: 435515-1-58-01
LCPW Project No.: 2014-11
Subject: CO-03-13

Mr. Robert Rudd,

CO-03-13: Pospiech is in agreement with Tierra, Inc. calculated value of work deleted from the contract at STA 81+25, Right (Milling and Resurfacing of Existing Asphalt Driveway) at the cost of (\$3,637.80). See attached Tierra, Inc. email of June 22, 2016 detailing same.

This should complete the items for Required Changes to CO# 3.

Please call if additional back-up is required.

Gary Bracken
Pospiech Contracting, Inc.

CO-03-13 Cost Data:

Driveway Milling and Resurfacing

$2323 \text{ SF} / 9 = 258 \text{ SY}$

$\$7.85 + \$6.25 = \$14.10/\text{SY}$

$\$14.10/\text{SY} \times 258 \text{ SY} = \$3,637.80$

Robert Rudd

From: Robert Rudd
Sent: Wednesday, June 22, 2016 7:53 AM
To: jscott@lakecountyfl.gov; jhinton@lakecountyfl.gov; GBracken@pospiechcontracting.com
Cc: Jeffrey Begovich
Subject: Hancock Rd, CO-03 Driveway Milling and Resurfacing

Terry, Joe, Gary;

See Driveway Takeoff Detail:

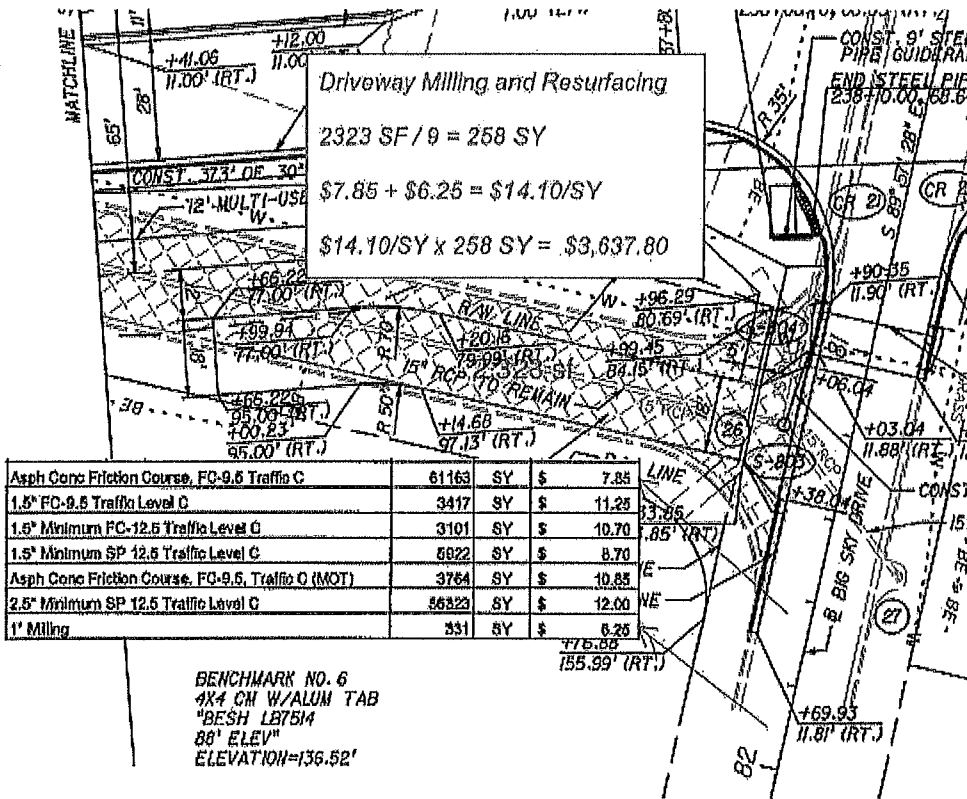

I get value of milling and resurfacing at \$3,637.80 per original plan. Area at 258 SY. Was 390 SY value measured length of full driveway.

Thanks,

Robert Rudd
 Tierra, Inc.