



Right-of-Way Utilization Permit

Please complete a separate application for each road

Applicant Name: Sabal Trail Transmission, LLC

Date: September 23, 2015

c/o Right-of-Way Department

Name Permit Will Be Returned To:

01 / 22 / 24
Section Township Range

400 Colonial Center Pkwy, Suite 300

Street Address

Lake Mary, FL 32746

City, State, Zip

Road Name: CR-565 Villa City Rd.

Subdivision and/or Site Plan Name / Number

1-888-596-7732

Telephone Number

gpkmetz@spectraenergy.com

Applicant's e-mail address

10-9-15 / Check JMK
Paid Date Rec'd By

If this project will result in any new above ground structures, poles, or facilities please state where and what is proposed. Applicant may be requested to provide an engineer's certification that roadway clearance and sight distances have been met.

Description of Work: Construct, operate and maintain an underground 36" Diameter Interstate Natural Gas pipeline under the above county road as depicted in drawing Number FL-LA-045.500.RC attached hereto. Sabal Trail Transmission has also attached a typical temporary equipment crossing drawing to be used on an as needed basis for movement of equipment from one side of the road to the other along with the appropriate traffic control plan.

Contractor: To Be Determined

Telephone Number: _____

Start of Construction Date: May 2016

Length of time of construction: 390 days

Is proposed work within city limits? No

If so, what city? _____

A letter of notification was mailed on One Call prior to construction to the following utilities & municipalities:

Applicant declares that he/she has determined the location of all existing underground and aerial utilities.

Applicant declares that he/she has read the attached application requirements and permit conditions.

Tina Faraca
Signature Of Applicant

Tina Faraca, Vice President of Sabal Trail Management, LLC, Operator for Sabal Trail Transmission, LLC
Applicant, Please Print Name

RD# 2215 **To be completed by County Staff**

Permit # 6923 Permit Fee: \$100.00 Fee Code: PWRW

Checked by: Joseph Hest Date Checked: 10-9-15

Approved by: Tom Swan Date Approved: 10-9-15

Special Conditions: _____ Expiration Date: 11-5-16

Call 352-253-6019 48 hours prior to starting work Ext 11-5-17 JS

For inspection, call the Lake County Public Works Department at 352-483-9000
Submit Permit to: Lake County Public Works, 437 Ardice Avenue, Eustis, FL 32726

Public Works Department
Road Operations Division

Related Permit # 6919-6934
Plans with Permit #

FL-LA-045.500.RC

Entered Data One	<u>10-8-15</u>
First Scan	Right-of-Way Utilization Permit
Updated Data One	Effective July 2012
Second Scan	<u>10-12-15</u>
Returned to Client	<u>11</u>

It is agreed that in the event the installation, adjustment or relocation of said utilities are scheduled to be done simultaneously with Lake County construction work, the applicant shall coordinate with Lake County before proceeding and shall cooperate with the Lake County's contractor to arrange the sequence of work so as not to delay the work of Lake County contractor, defend any legal claims of Lake County's contractor due to delays caused by the applicant's failure to comply with the approved schedule, and shall comply with all provisions of the law and Lake County's current *Utility Accommodation Manual*. The applicant shall not be responsible for delay beyond its control.

All right-of-way utilization activities shall be reported to Sunshine State One-Call at least seventy-two (72) hours prior to commencement.

Guarantee and Responsibility for Compliance:

In the case of noncompliance with the County's requirements, this permit will be void and the facility will be brought into compliance or removed from the right-of-way at no cost to the County.

The County may issue "Stop Work" order(s) upon any permittee committing or creating an unsafe act which may create a public hazard or who is not complying with this permit or the applicable codes. The order shall remain in effect until such time as these matters are corrected.

Permits shall be issued with the understanding that the applicant shall guarantee all work performed under the terms of the permit for a period of one (1) year from the date of final inspection and acceptance of work.

Any failures shall be repaired by the applicant, at the direction of the County, within five (5) days, unless the urgency of the problem requires a quicker reaction time.

The applicant shall be responsible for all repair costs incurred due to damages to existing utilities by failure to use due care, including errors in locating existing utilities during construction.

Removal/Relocation of Improvements: Upon ten (10) days written notice, the applicant shall be required to remove and/or relocate the improvements placed within the right-of-way at the applicant's sole expense.

It is expressly stipulated that this permit is a license for permissive use only and that the placing of facilities upon public property pursuant to this permit shall not operate to create or vest any property right in said holder.

It is understood and agreed that the rights and privileges herein set out are granted only to the extent of the County's right, title and interest in the land to be entered upon and used by the holder, and the holder will, at all times, assume all risk of and indemnify, defend and save harmless the County of Lake from and against any and all loss, damage, cost or expense arising in any manner on account of the exercise or attempted exercises by said holder of the aforesaid rights and privileges.

I have read and understand the above requirements

Tina Faraca

Applicant's Signature

Tina V. Faraca, Vice President of Sabal Trail Management, LLC,
Operator for Sabal Trail Transmission, LLC
Public Works Department
Road Operations Division

9/24/15

Date

*See attached
SEPT. 2015
Version*

FL-LA-045.500.RC

Right-of-Way Utilization Permit
Effective July 2012



Right-of-way Utilization Permit Requirements

The purpose of the Right-of-Way Utilization permit is to control the use of public rights-of-way and public easements and protect the health, safety and welfare of the public. Any work within public rights-of-way requires an approved right-of-way utilization permit.

Application Requirements:

For each road involved, please submit one (1) original application and supporting documentation to the Lake County Department of Public Works.

Completed applications must include a sketch or construction plans drawn to scale, showing the following:

1. The offset from the centerline of the right-of-way or roadway to the proposed utility installation, the road right-of-way width and pavement width, the distance from the edge of pavement to the utility, sidewalks, and the location of all other utilities, including traffic signal utilities, within the area of work.
2. One or more typical cross sections to adequately reflect the location of the utility. Please indicate the minimum vertical clearance above or below the pavement or natural ground.
3. The location of the area of work in relation to the nearest road intersection, bridges, railroad crossings, and other physical features. Please include a location or vicinity map showing the general location of the installation.

All permit applications must demonstrate that the proposed improvements conform to the right-of-way utilization requirements included in the *Lake County Land Development Regulations*.

Projects of significant length and land size may require a complete right-of-way survey.

A performance bond may be required of the applicant in the event the work covered by the right-of-way utilization permit has the potential to significantly damage the right-of-way. The amount of the performance bond shall be 110% of the estimated cost to repair such damage, as determined by Lake County.

Prior to construction, applicant shall provide written notice to all property owners adjacent to the project limits. This notice shall include, at a minimum, the anticipated construction schedule, maintenance of traffic plan and any impacts, permanent or temporary, to the adjacent properties. The notice must provide contact information including the name and telephone number of the project manager. Within a minimum of fourteen (14) calendar days prior to construction, applicant shall provide to the County a copy of the notification with a list of the parties notified.

A copy of the approved permit and related supporting documents shall be on site at all times during construction.

Permit Conditions:

Whenever necessary for the construction, maintenance, operation or alteration of the right-of-way, as determined by the County, any or all of the appurtenances authorized by this permit shall be immediately removed from the right-of-way or relocated, as required by the County, at the expense of the applicant unless reimbursement is specifically authorized.

If above ground utilities are being replaced, the old utilities and utility appurtenances must be removed from County right-of-way within thirty (30) days after new utilities are installed.

All work, materials and equipment shall meet all County codes and standards and shall be subject to inspection by the County. All right-of-way disturbed by this work shall be restored to its original condition or better and in accordance to applicable County Codes. All disturbed areas must be sodded, matching existing grass type. Bahia sod shall be used if no grass is present at time of construction.

The construction and maintenance of this utility shall not interfere with the property and rights of a prior applicant.

Where possible, excavation shall not be allowed within five (5) feet from the edge of the pavement. Situations that cannot meet this requirement shall require prior approval of the County.

The County shall be notified twenty-four (24) hours in advance of starting work. In the interest of public safety all operations shall take place during daylight hours, unless specifically authorized, and discontinued by sunset with proper signage and traffic control devices maintained during off hours.

All traffic detours shall be restricted to the limits of right-of-way with necessary flagmen and marking devices. A traffic detour or lane closure shall require specific approval by the County.

Written approval from the Lake County Engineer shall be required before any alterations to existing traffic signal equipment including, but not limited to: vehicle detection loops and signal timing.

If traffic signal vehicle detection loops are rendered inoperable, temporary detection shall be installed within twenty-four (24) hours.

All traffic signal utilities disturbed by this work shall be restored to its original condition or better. Traffic signal utilities include but not limited to: vehicle detection loops, conduit, cabling, pull boxes, pedestrian signal equipment, span assemblies, signal heads, cabinet assemblies, cameras and fiber optic infrastructure.

All utility construction and maintenance shall be performed with proper shoring, barricades, and maintenance of traffic signage in accordance with the FHWA Manual on Uniform Traffic Control Devices (MUTCD), OSHA law and regulations, and the Florida Department of Transportation Highway Safety Plan.

The County shall not be responsible for damages to any structure placed within the right-of-way. All structures shall be properly maintained, adequately visible or properly delineated to prevent damage due to normal maintenance of the right-of-way.

Open cuts of roads will not be allowed unless specifically authorized by Lake County. Directional bore or jack and bore operations should maintain a five (5) foot minimum clearance from edge of pavement on road crossing each side. Recommended bore depth is thirty-six inches (36") and a minimum bore depth is thirty inches (30"). Any overhead installations should maintain a minimum of eighteen (18) feet vertical clearance over all roadways and driveways.

This permit is effective for one year from its approval date, unless otherwise rescinded by Lake County.

Inspection and Approval of Work:

The County shall have the right to inspect and approve all materials and/or phases of work. Final inspection and acceptance of work by the County must be obtained to document the completion of the work. All work shall be subject to the construction requirements and inspections as required in other provisions of the *Lake County Land Development Regulations*. Pursuant to Section 337.403(1), Florida Statutes, any utility placed upon, under, over, or along any public road or publicly owned rail corridor that is found by Lake County to be unreasonably interfering in any way with the convenient, safe, or

continuous use, or maintenance, improvement, extension, or expansion, of such public road or publicly owned rail corridor shall, upon thirty (30) days written notice to the utility or its agent by Lake County be removed or relocated by such utility at its own expense.

It is agreed that in the event the installation, adjustment or relocation of said utilities are scheduled to be done simultaneously with Lake County construction work, the applicant shall coordinate with Lake County before proceeding and shall cooperate with the Lake County's contractor to arrange the sequence of work so as not to delay the work of Lake County contractor, defend any legal claims of Lake County's contractor due to delays caused by the applicant's failure to comply with the approved schedule, and shall comply with all provisions of the law and Lake County's current *Utility Accommodation Manual*. The applicant shall not be responsible for delay beyond its control.

All right-of-way utilization activities shall be reported to Sunshine State One-Call at least seventy-two (72) hours prior to commencement.

Guarantee and Responsibility for Compliance:

In the case of noncompliance with the County's requirements, this permit will be void and the facility will be brought into compliance or removed from the right-of-way at no cost to the County.

The County may issue "Stop Work" order(s) upon any permittee committing or creating an unsafe act which may create a public hazard or who is not complying with this permit or the applicable codes. The order shall remain in effect until such time as these matters are corrected.

Permits shall be issued with the understanding that the applicant shall guarantee all work performed under the terms of the permit for a period of one (1) year from the date of final inspection and acceptance of work.

Any failures shall be repaired by the applicant, at the direction of the County, within five (5) days, unless the urgency of the problem requires a quicker reaction time.

The applicant shall be responsible for all repair costs incurred due to damages to existing utilities by failure to use due care, including errors in locating existing utilities during construction.

Removal/Relocation of Improvements: Upon ten (10) days written notice, the applicant shall be required to remove and/or relocate the improvements placed within the right-of-way at the applicant's sole expense.

It is expressly stipulated that this permit is a license for permissive use only and that the placing of facilities upon public property pursuant to this permit shall not operate to create or vest any property right in said holder.

It is understood and agreed that the rights and privileges herein set out are granted only to the extent of the County's right, title and interest in the land to be entered upon and used by the holder, and the holder will, at all times, assume all risk of and indemnify, defend and save harmless the County of Lake from and against any and all loss, damage, cost or expense arising in any manner on account of the exercise or attempted exercises by said holder of the aforesaid rights and privileges.

I have read and understand the above requirements

Applicant's Signature/Date

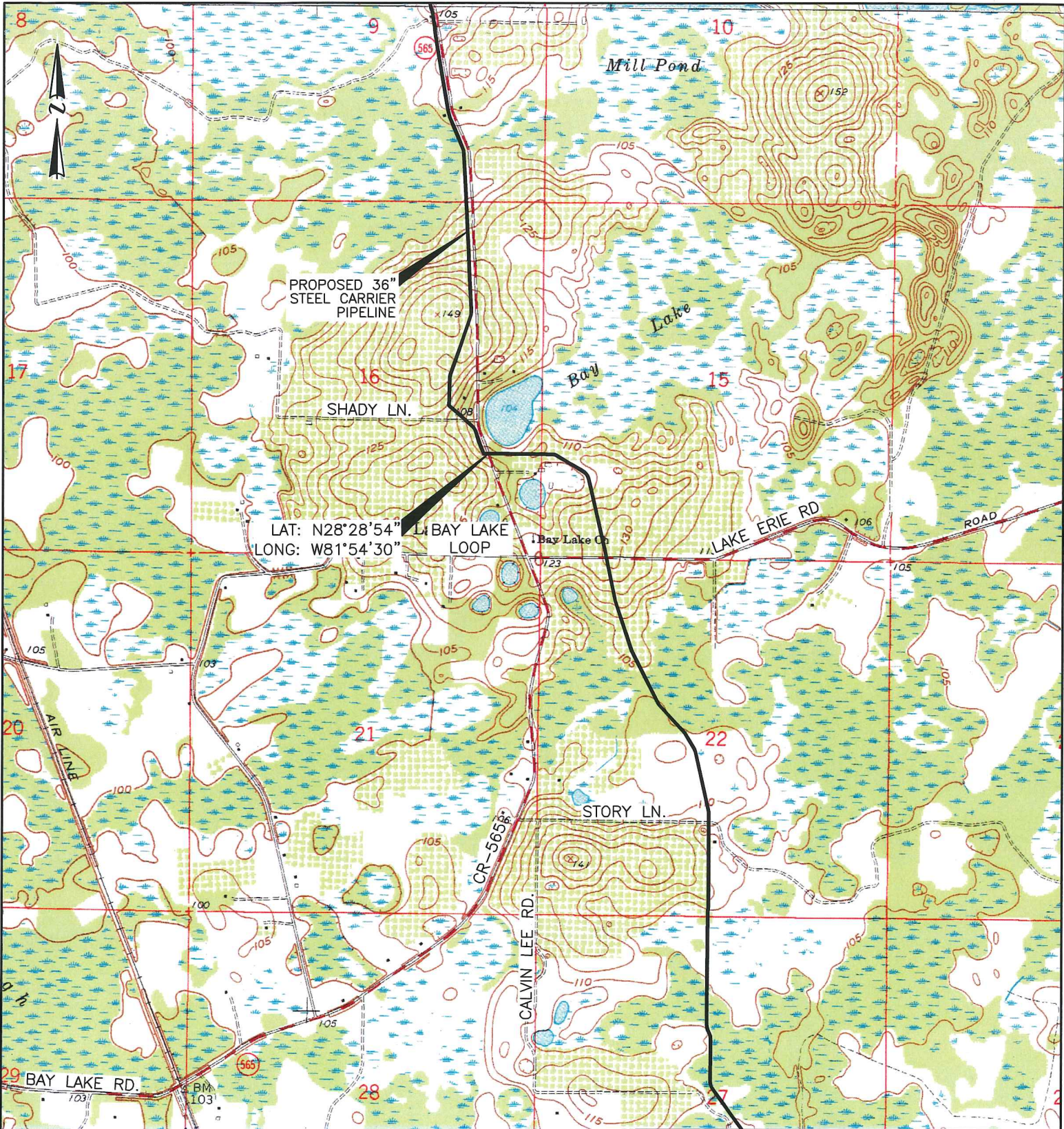

LAT: N28°28'54"
LONG: W81°54'30"

PROPOSED 36"
STEEL CARRIER
PIPELINE

SHADY LN.

BAY LAKE LOOP

STORY LN.

LAKE ERIE RD

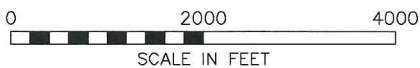



SABAL TRAIL TRANSMISSION
PROPOSED 36" PIPELINE
ROAD CROSSING VICINITY MAP
CR-565

DRAWN BY:	JF	DATE:	04-23-15
CHECKED BY:	BG	DATE:	05-20-15
SCALE:	AS SHOWN	W.O.:	
0	ISSUED FOR PERMIT	05-21-15	
REV.	DESCRIPTION	DATE	

LAKE COUNTY,	FLORIDA
DRAWING NUMBER:	FL-LA-045.500.RC
SHEET NO.	2 OF 2
REV.	0

LAST REVISION 07/01/05	REVISION DESCRIPTION	FDOT DESIGN STANDARDS	2015	TWO-LANE, TWO-WAY, WORK OUTSIDE SHOULDER	INDEX NO. 601	SHEET NO. 1 of 1
---------------------------	----------------------	---------------------------------	------	--	------------------	---------------------

SYMBOLS

	Work Area
	Lane Identification + Direction of Traffic

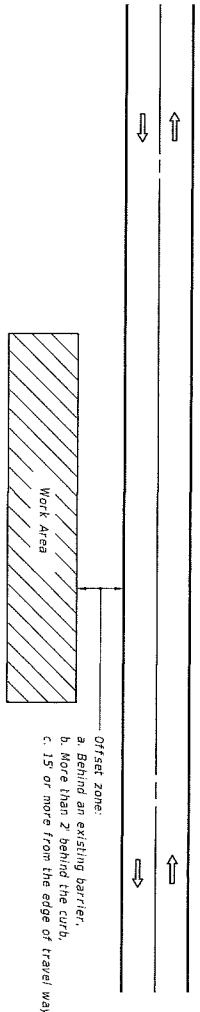

- a. Behind an existing barrier.
- b. More than 2' behind the curb.
- c. 15' or more from the edge of travel way.

GENERAL NOTES

1. If the work operation (excluding establishing and terminating the work area) requires that two or more work vehicles cross the offset zone in any one hour, traffic control will be in accordance with Index No. 602.
2. No special signing is required.
3. When a side road intersects the highway within the work area, additional TTC devices shall be placed in accordance with other applicable TCZ indexes.
4. When construction activities encroach on a sidewalk refer to Index No. 660.
5. For general TCZ requirements and additional information, refer to Index No. 600.

CONDITIONS

WHERE ANY VEHICLE, EQUIPMENT, WORKERS AND THEIR ACTIVITIES ARE BEHIND AN EXISTING BARRIER, MORE THAN 2' BEHIND THE CURB, OR 15' OR MORE FROM THE EDGE OF TRAVEL WAY.

FL-LA-045.500.RC



View Downstream (CR 565)

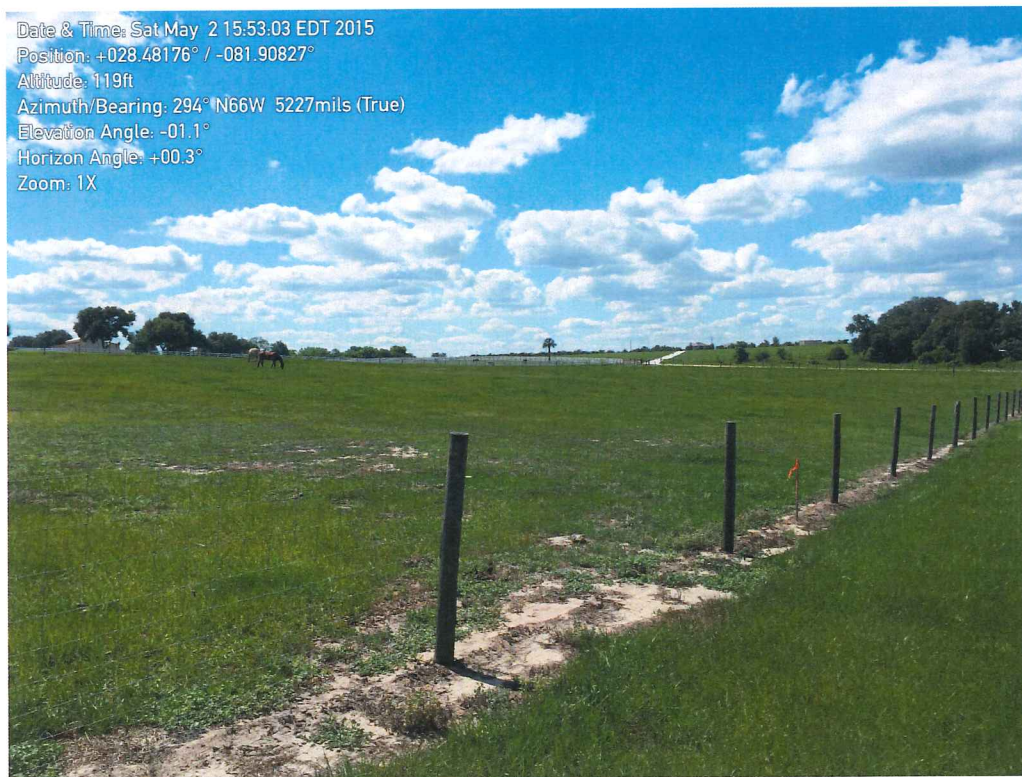

View Upstream (CR 565)

FL-LA-045.500.RC



View South (CR 565)



View North (CR 565)

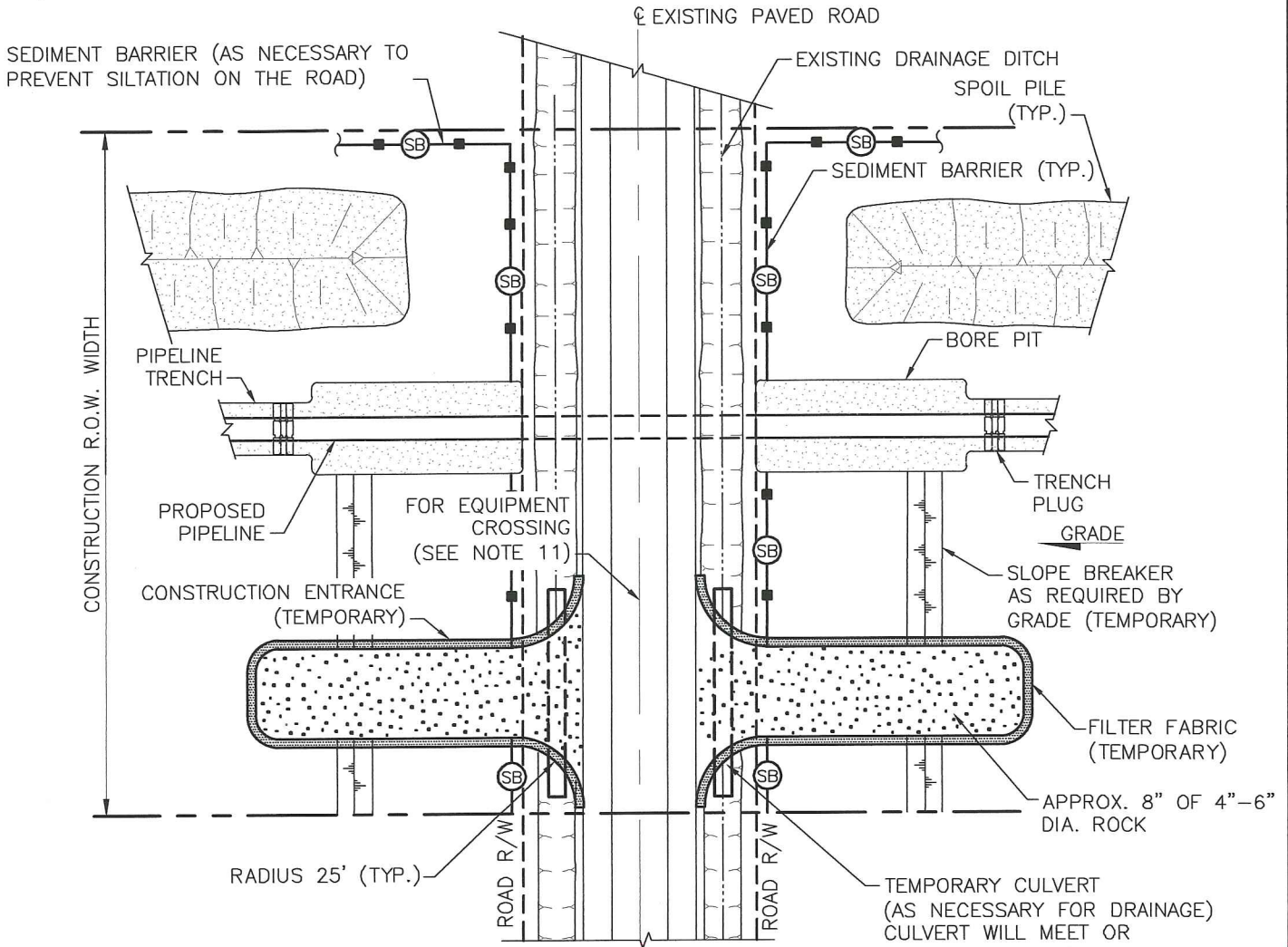

NOTES:

1. PROVIDE MINIMUM OF 3.5 FEET OF COVER BETWEEN TOP OF PIPE AND LOWEST POINT IN THE BORROW DITCHES, OR PROVIDE MINIMUM 5 FEET OF COVER BETWEEN PIPE AND TOP OF ROAD SURFACE, OR MINIMUM DEPTH REQUIRED BY PERMIT, WHICHEVER DIMENSION PROVIDES GREATER DEPTH FOR PIPELINE.
2. TRENCH AND BORE PIT SHALL BE DESIGNED IN ACCORDANCE WITH OSHA REQUIREMENTS.
3. SEDIMENT BARRIERS SHALL BE INSTALLED AT THE BASE OF SLOPES ADJACENT TO ROAD CROSSINGS WHERE VEGETATION IS DISTURBED TO INTERCEPT SURFACE RUNOFF.
4. PROTECTION FOR SPOIL PILES SHALL BE INSTALLED ONLY WHERE SEDIMENT BARRIERS ACROSS THE ENTIRE DISTURBED AREA ARE NOT REQUIRED.
5. SEDIMENT BARRIERS SHALL REMAIN IN PLACE UNTIL PERMANENT REVEGETATION IS ESTABLISHED.
6. WATER REMOVED FROM BORE PIT AND RECEIVING PIT SHALL BE FILTERED THROUGH A DEWATERING STRUCTURE OR FILTER BAG.
7. IF WELL POINTING IS REQUIRED PRIOR TO EXCAVATING BORE PITS, CONTRACTOR SHALL CONSULT WITH COMPANY'S ENVIRONMENTAL INSPECTOR PRIOR TO COMMENCEMENT OF WORK ORDER TO DETERMINE PROPER DEWATERING DISCHARGE LOCATION.
8. CONTRACTOR SHALL BE REQUIRED TO KEEP THE ROAD CLEAN OF DEBRIS AT ALL TIMES AND WILL USE FDOT APPROVED TRACKING MATERIAL TO REMOVE DIRT ROAD DEBRIS FROM EQUIPMENT.
9. CONTRACTOR MAY ELECT TO UTILIZE SHEET PILING IN ORDER TO STABILIZE TRENCH.
10. DEPENDING ON TOPOGRAPHY AND STATE REQUIREMENTS, SEDIMENT BARRIERS MAY BE REQUIRED ACROSS THE ENTIRE CONSTRUCTION RIGHT OF WAY AT THE EDGE OF ROAD.
11. TIRES AND/OR PLYWOOD WILL BE USED ON ROAD SURFACES FOR TRACKED EQUIPMENT CROSSINGS.

(SB) TEMPORARY SEDIMENT BARRIER OF SILT FENCE AND/OR STRAW BALES.

DRAWN BY:	JW	DATE:	06/08/15
CHECKED BY:	BG	DATE:	08/27/15
SCALE:	NONE	W.O.:	
REV.	DESCRIPTION	DATE	
2	RE-ISSUED FOR PERMIT	08/27/15	
1	RE-ISSUED FOR PERMIT	07/29/15	
0	ISSUED FOR PERMIT	07/13/15	



SABAL TRAIL TRANSMISSION
PROPOSED 36" & 24" PIPELINE
TYPICAL BORED ROAD & EQUIPMENT CROSSING
AND CONTROL MEASURE

DRAWING NUMBER:	1657-PL-DG-28158	SHEET NO.	1 OF 1	REV.	2
-----------------	------------------	-----------	--------	------	---

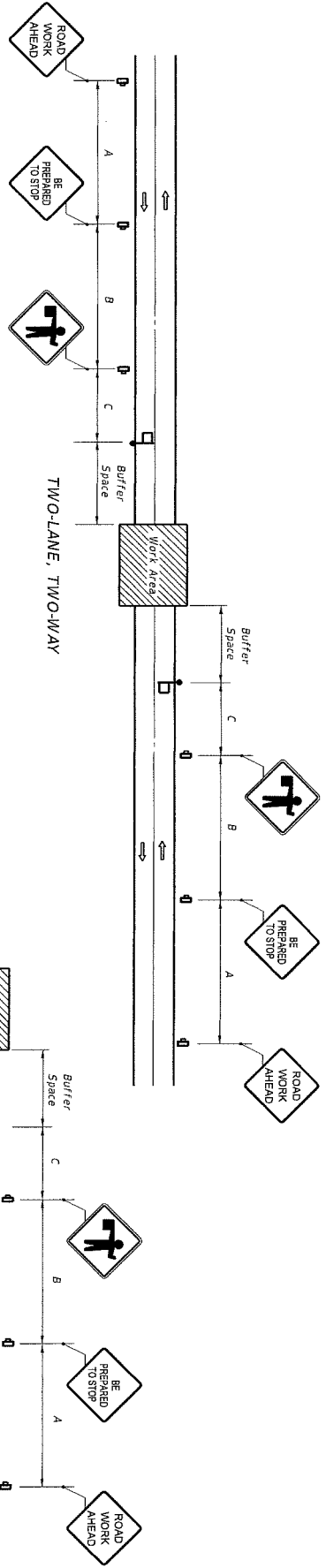

BUFFER SPACE		
Speed (mph)	Dist. (ft.)	
25	155	
30	200	
35	250	
40	305	
45	360	
50	425	
55	495	
60	570	
65	645	

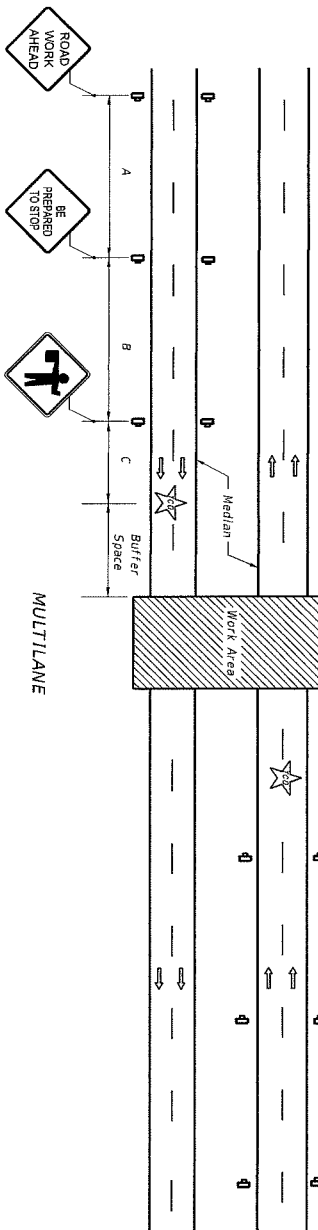

SYMBOLS

- Work Area
- Sign
- Work Zone Sign
- Flagger
- Traffic Control Officer
- Lane Identification + Direction of Traffic

DISTANCE BETWEEN SIGNS			
Speed (mph)	Spacing (ft.)		
	A	B	C
40 or less	200	200	200
45	350	350	350
50 or greater	500	500	500

GENERAL NOTES

1. This index does not apply to limited access facilities.
2. When a side road intersects the highway within the TTC zone, additional TTC devices shall be placed in accordance with applicable TCZ indexes.
3. Traffic volume or complexity of the roadway may dictate additional devices, signs, flagmen and/or a traffic control officer.
4. The buffer space may be omitted if there are no sight obstructions to vehicles approaching the Flagger/Officer for distance equal to the buffer space.
5. A Flagger may be substituted for a Traffic Control Officer and the BE PREPARED TO STOP sign may be omitted, when the following conditions are met:
 - a. Speed limit is 45 mph or less.
 - b. No sight obstructions to vehicles approaching the Flagger/Officer for a distance equal to the buffer space.
 - c. Vehicles in the work area have high-intensity, rotating, flashing, oscillating, or strobe lights operating.
6. On undivided highways the median sign as shown are to be omitted.
7. For general TCZ requirements and additional information refer to FDOT Index No. 600.

CONDITIONS

PLANNED CLOSURE NOT EXCEEDING 5 MINUTES.

LAST REVISION 07/01/13	DESCRIPTION: FDOT 2015 DESIGN STANDARDS	INDEX NO. 625	SHEET NO. 1 of 1
TEMPORARY ROAD CLOSURE 5 MINUTES OR LESS			

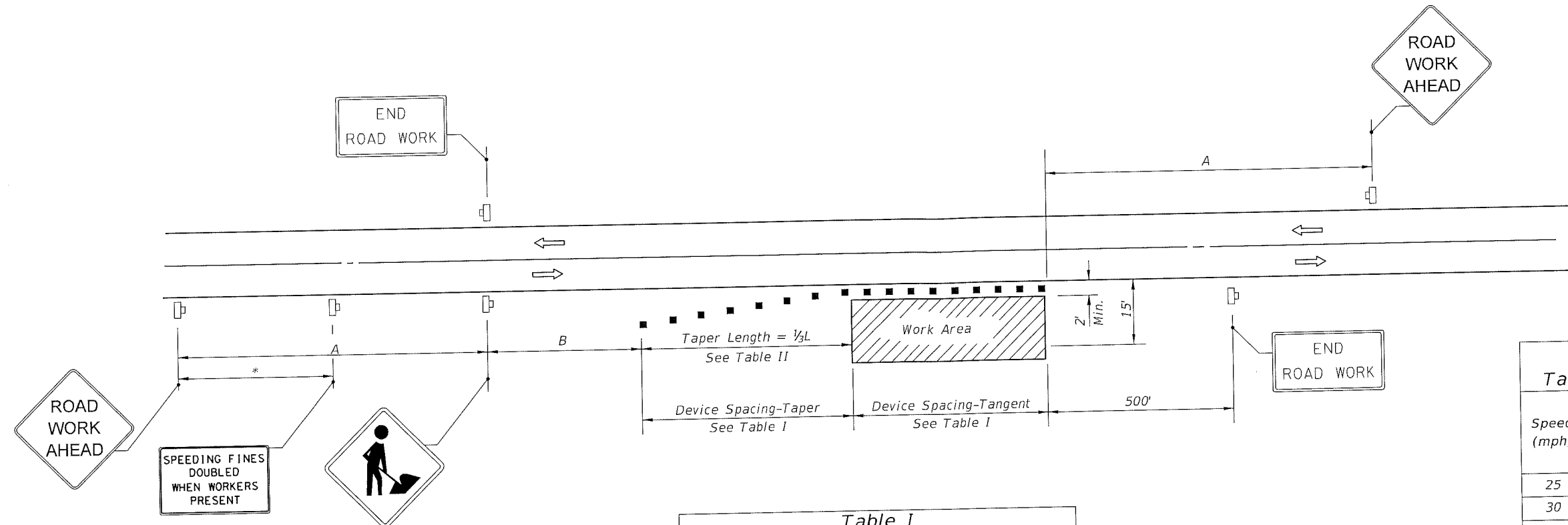

Speed	Spacing (ft.)	
	A	B
40 mph or less	200	200
45 mph	350	350
50 mph or greater	500	500

*Midway between signs.

Speed (mph)	Max. Distance Between Devices (ft.)			
	Cones or Tubular Markers		Type I or Type II Barricades or Vertical Panels or Drums	
	Taper	Tangent	Taper	Tangent
25	25	50	25	50
30 to 45	25	50	30	50
50 to 70	25	50	50	100

Speed (mph)	$\frac{1}{2}L$ (ft)			Notes
	8' Shldr.	10' Shldr.	12' Shldr.	
25	28	35	42	$L = \frac{WS^2}{60}$
30	40	50	60	
35	55	68	82	
40	72	90	107	
45	120	150	180	$L = WS$
50	133	167	200	
55	147	183	220	
60	160	200	240	
65	173	217	260	
70	187	233	280	

8' minimum shoulder width
 $\frac{1}{2}L$ = Length of shoulder taper in feet
 W = Width of total shoulder in feet (combined paved and unpaved width)
 S = Posted speed limit (mph)

SYMBOLS

- Work Area
- Channelizing Device (See Index No. 600)
- Work Zone Sign
- Lane Identification + Direction of Traffic

GENERAL NOTES

- When four or more work vehicles enter the through traffic lanes in a one hour period or less (excluding establishing and terminating the work area), the advanced FLAGGER sign shall be substituted for the WORKERS sign. For location of flaggers and FLAGGER signs, see Index No. 603.
- SHOULDER WORK sign may be used as an alternate to the WORKER symbol sign only on the side where the shoulder work is being performed.
- When a side road intersects the highway within the TTC zone, additional TTC devices shall be placed in accordance with other applicable TCZ Indexes.
- For general TCZ requirements and additional information, refer to Index No. 600.

DURATION NOTES







- Signs and channelizing devices may be omitted if all of the following conditions are met:
 - Work operations are 60 minutes or less.
 - Vehicles in the work area have high-intensity, rotating, flashing, oscillating, or strobe lights operating.

CONDITIONS

WHERE ANY VEHICLE, EQUIPMENT, WORKERS OR THEIR ACTIVITIES ENCROACH THE AREA CLOSER THAN 15' BUT NOT CLOSER THAN 2' TO THE EDGE OF TRAVEL WAY.

6/16/2015 10:45:36 AM

SYMBOLS:

-  Work Area
-  Channelizing Device (See Index No. 600)
-  Work Zone Sign
-  Flagger
-  Automated Flagger Assistance Devices (AFAD), With Gate
-  Lane Identification + Direction of Traffic

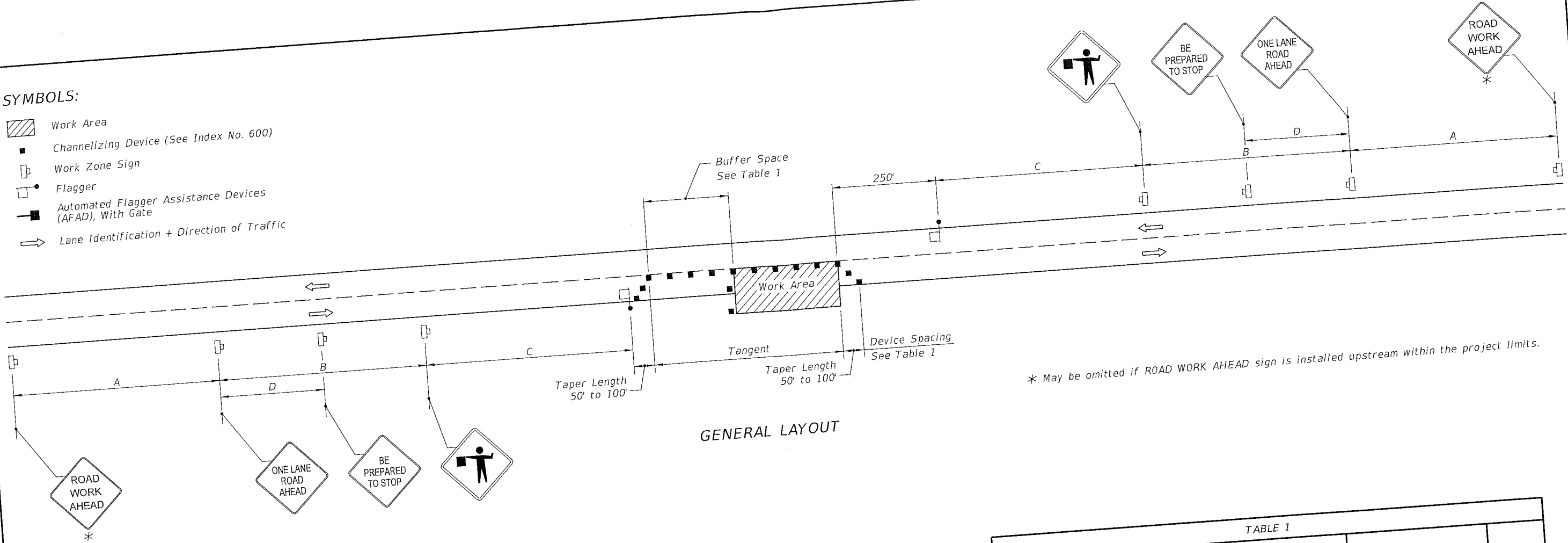

* May be omitted if ROAD WORK AHEAD sign is installed upstream within the project limits.

GENERAL LAYOUT

GENERAL NOTES:

1. Special Conditions may be required in accordance with these notes and the following sheets.
2. If the Work Area encroaches on the Centerline, use the Layout for Temporary Lane Shift to Shoulder on Sheet 2 only if the Existing Paved Shoulder width is sufficient to provide for an 11' lane between the Work Area and the Edge of Existing Paved Shoulder. Reduce the posted speed when appropriate.
3. Temporary Raised Rumble Strips:
 - a. Use when both of the following conditions are met concurrently:
 - i. Existing Posted Speed is 50 mph or greater;
 - ii. Work duration is greater than 60 minutes.
 - b. Use a consistent Strip color throughout the work zone.
 - c. Place each Rumble Strip Set transversely across the lane at locations shown.
 - d. Use Option 1 or Option 2 as shown on Sheet 2. Use only one option throughout work zone.
4. Additional one-way control may be provided by the following means:
 - a. Flag-carrying vehicle;
 - b. Official vehicle;
 - c. Pilot vehicles;
 - d. Traffic signals.

When flaggers are the sole means of one-way control, the flaggers must be in sight of each other or in direct communication at all times.
5. When a side road intersects the highway within the TTC zone, place additional TTC devices in accordance with other applicable TCZ Indexes.
6. The two channelizing devices directly in front of the work area may be omitted provided vehicles in the work area have high-intensity rotating, flashing, oscillating, or strobe lights operating.

7. When Buffer Space cannot be attained due to geometric constraints, use the greatest attainable length, not less than 200 ft.
8. Railroad Crossings:
 - a. If an active railroad crossing is located closer to the Work Area than the queue length plus 300 feet, extend the Buffer Space as shown on Sheet 2.
 - b. If the queuing of vehicles across an active railroad crossing cannot be avoided, provide a uniformed traffic control officer or flagger at the highway-rail grade crossing to prevent vehicles from stopping within the highway-rail grade crossing, even if automatic train warning devices are in place.
9. ROAD WORK AHEAD and the BE PREPARED TO STOP signs may be omitted if all of the following conditions are met:
 - a. Work operations are 60 minutes or less.
 - b. Speed limit is 45 mph or less.
 - c. There are no sight obstructions to vehicles approaching the work area for a distance equal to the Buffer Space shown in Table 1.
 - d. Vehicles in the work area have high-intensity, rotating, flashing, oscillating, or strobe lights operating.
 - e. Volume and complexity of the roadway has been considered.
 - f. If a railroad crossing is present, vehicles will not queue across rail tracks.
 - g. AFADs are not in use.
10. See Index 600 for general TCZ requirements and additional information.
11. Automated Flagger Assistance Devices (AFADs) may be used in accordance with the Notes on Sheet 3.

TABLE 1

Posted Speed	DEVICE SPACING				Distance Between Signs				Buffer Space
	Maximum Spacing of Cones or Tubular Markers		Maximum Spacing of Type I or Type II Barricades/Panels/Drums		A	B	C	D	
	On a Taper	On a Tangent	On a Taper	On a Tangent					
25	20'	50'	20'	50'	200'	200'	200'	100'	155'
30	20'	50'	20'	50'	200'	200'	200'	100'	200'
35	20'	50'	20'	50'	200'	200'	200'	100'	250'
40	20'	50'	20'	50'	200'	200'	200'	100'	305'
45	20'	50'	20'	50'	350'	350'	350'	175'	360'
50	20'	50'	20'	50'	500'	500'	500'	250'	425'
55	20'	50'	20'	100'	500'	500'	1000'	500'	495'
60	20'	50'	20'	100'	2640'	1500'	1000'	500'	570'
65	20'	50'	20'	100'	2640'	1500'	1000'	500'	645'
70	20'	50'	20'	100'	2640'	1500'	1000'	500'	730'

CONDITIONS

WHERE ANY VEHICLE, EQUIPMENT, WORKERS OR THEIR ACTIVITIES ENCR OACH THE AREA BETWEEN THE CENTERLINE AND A LINE 2' OUTSIDE THE EDGE OF TRAVEL WAY.

TWO-LANE, TWO-WAY, WORK WITHIN THE TRAVEL WAY

INDEX NO. 603
SHEET NO. 1 of 3

DESCRIPTION:

6/16/2015 10:46:45 AM

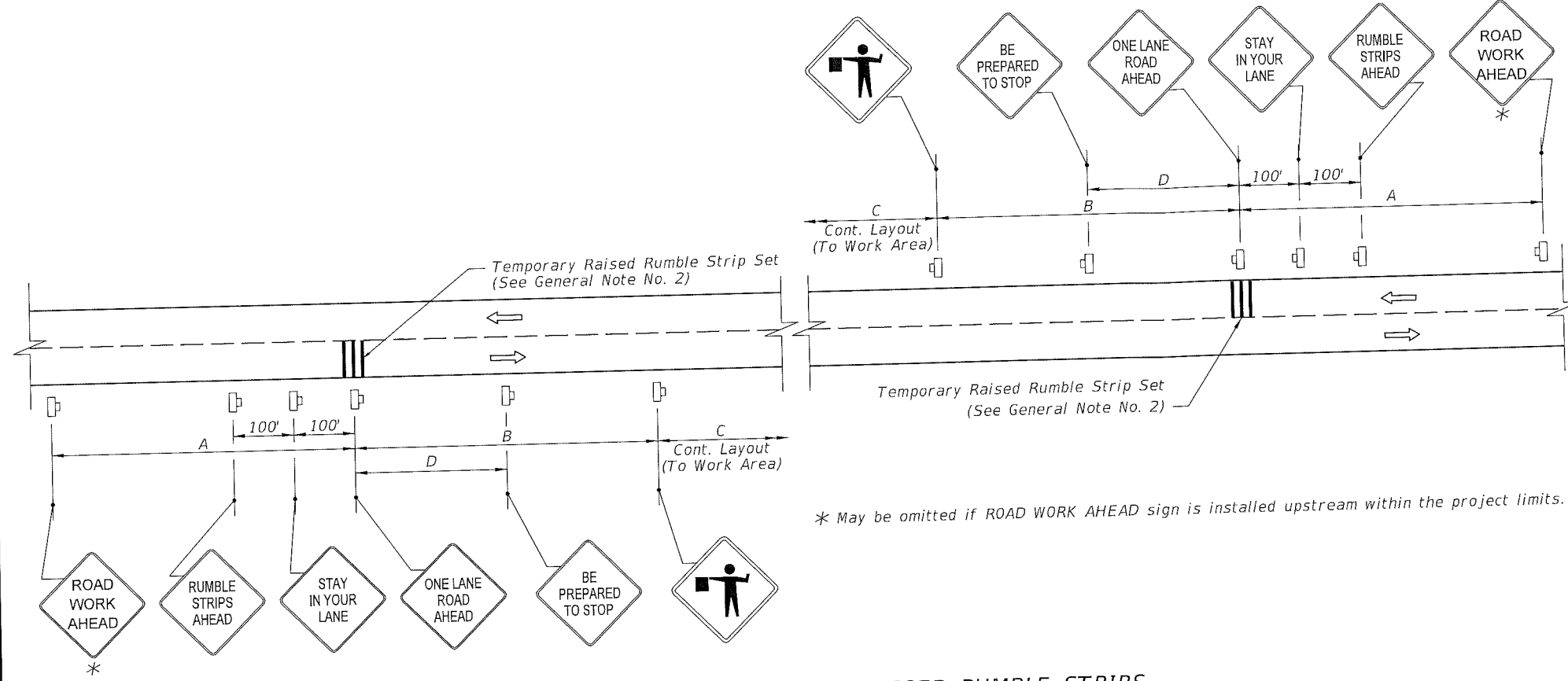

LAYOUT FOR TEMPORARY RAISED RUMBLE STRIPS WHEN REQUIRED WITH ADDITIONAL SIGNS

* May be omitted if ROAD WORK AHEAD sign is installed upstream within the project limits.

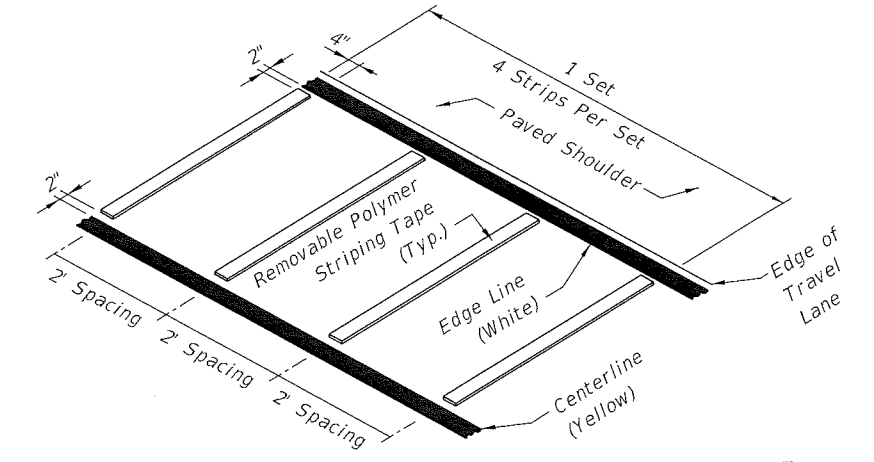

OPTION 1 - REMOVABLE POLYMER STRIPING TAPE RUMBLE STRIP SET

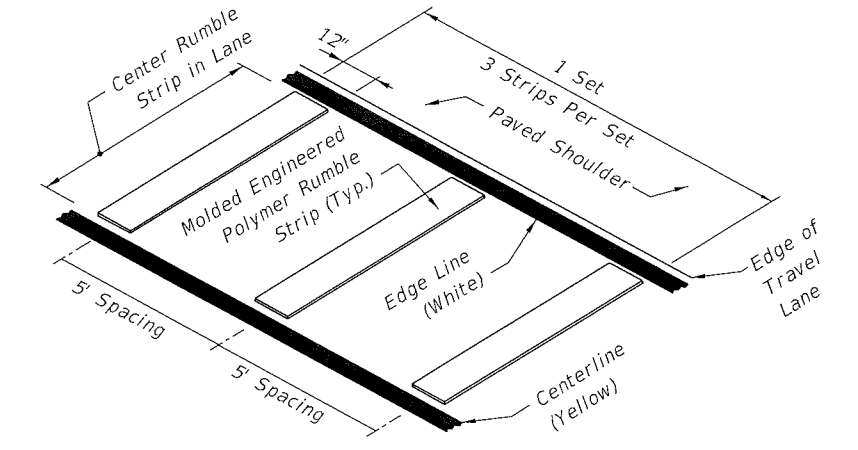

OPTION 2 - MOLDED ENGINEERED POLYMER RUMBLE STRIP SET

TEMPORARY RAISED RUMBLE STRIPS

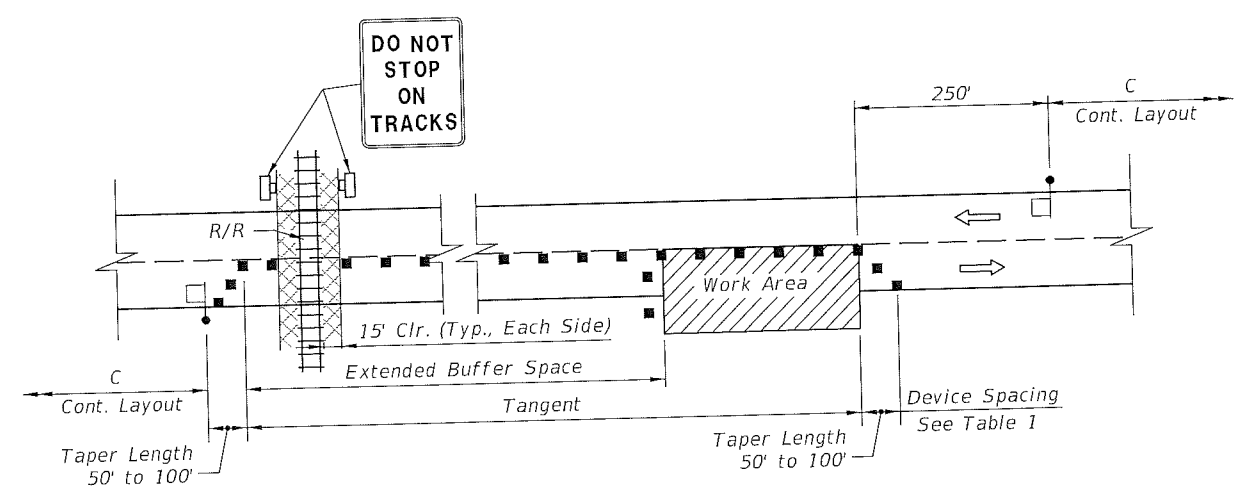

LAYOUT FOR RAILROAD CROSSING BUFFER SPACE EXTENSION

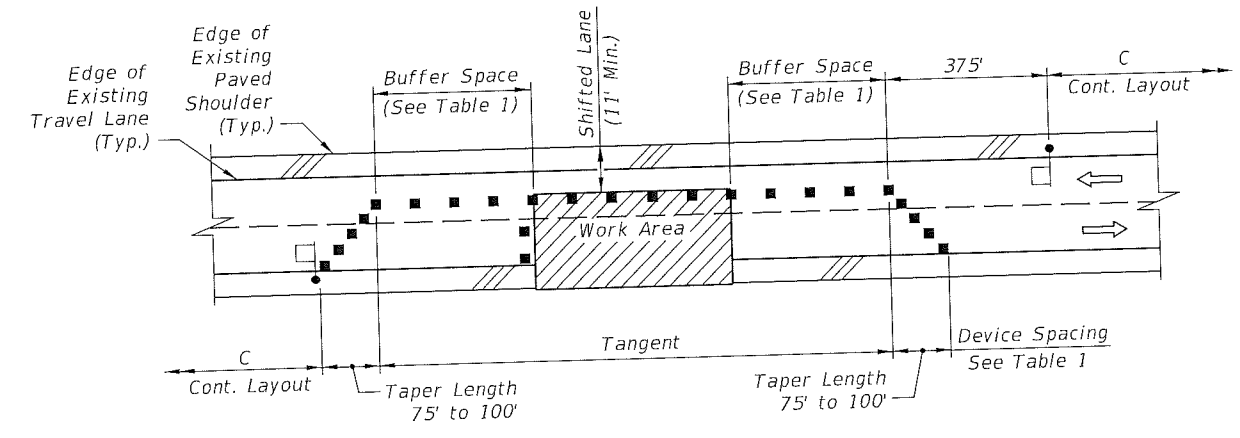

LAYOUT FOR TEMPORARY LANE SHIFT TO SHOULDER WHEN WORK AREA ENCROACHES ON THE CENTERLINE

SPECIAL CONDITIONS

6/16/2015 10:46:46 AM

LAST REVISION	DESCRIPTION:
07/01/15	

FDOT 2016 DESIGN STANDARDS

TWO-LANE, TWO-WAY, WORK WITHIN THE TRAVEL WAY

INDEX NO.	SHEET NO.
603	2 of 3

AUTOMATED FLAGGER ASSISTANCE DEVICES NOTES:

1. Illuminate the flagging station when the AFAD is used at nighttime.
2. When the AFAD is not in use, remove or cover signs and move AFAD device outside the clear zone or shield it with a barrier or crash cushion.
3. Only qualified flaggers who have been trained in the operation of the AFAD may operate the AFAD. When in use, each AFAD must be in view of and attended at all times by the flagger operating the device. Use two flaggers and one of the following methods in the deployment of AFAD's:
 - Method 1: Place an AFAD at each end of the temporary traffic control zone.
 - Method 2: Place an AFAD at one end of the temporary traffic control zone and a flagger at the opposite end.
4. A single flagger may simultaneously operate two AFAD's (Method 1) or may operate a single AFAD on one end of the temporary traffic control zone while being the flagger at the opposite end of the temporary traffic control zone (Method 2) if all four of the following conditions are present:
 - a. The flagger has an unobstructed view of the AFAD(s);
 - b. The flagger has an unobstructed view of approaching traffic in both directions;
 - c. For Method 1, the AFAD's are less than 800 ft apart. For Method 2, the AFAD and the flagger are less than 800 ft apart.
 - d. Two trained flaggers are available on-site to provide normal flagging operations should an AFAD malfunction.

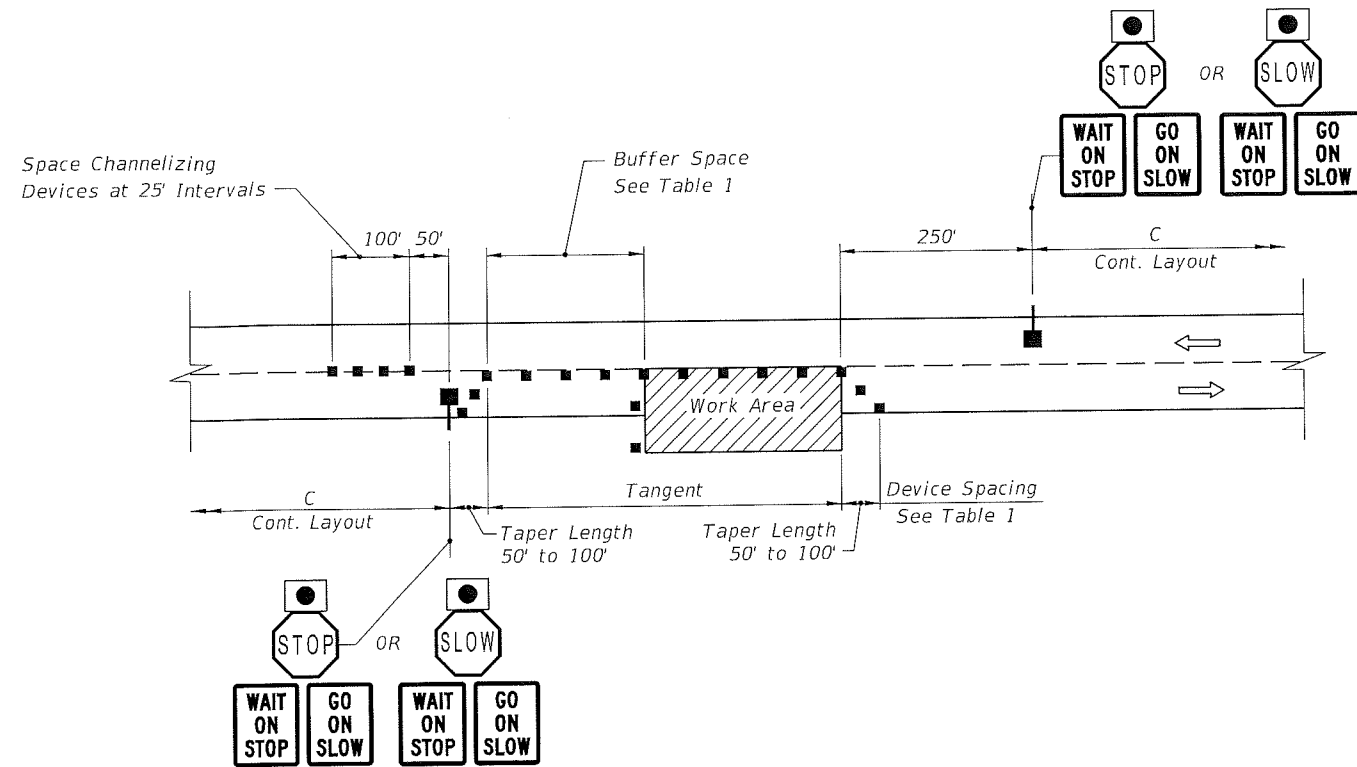

LAYOUT FOR STOP/SLOW AFAD
METHOD 1 - 2 AFAD's

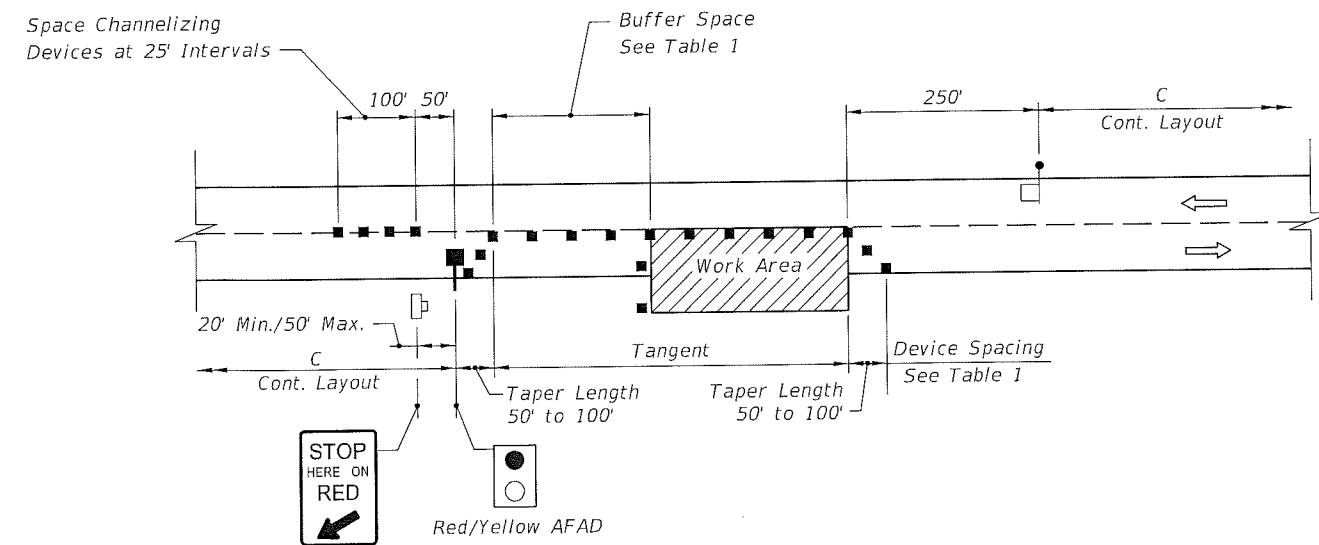

LAYOUT FOR RED/YELLOW AFAD
METHOD 2 - 1 AFAD & FLAGGER

AUTOMATED FLAGGER ASSISTANCE DEVICES (AFADs)

6/16/2015 10:46:46 AM

LAST REVISION 07/01/15	REVISION	DESCRIPTION:	 2016 DESIGN STANDARDS	TWO-LANE, TWO-WAY, WORK WITHIN THE TRAVEL WAY	INDEX NO. 603	SHEET NO. 3 of 3
---------------------------	----------	--------------	---	--	------------------	---------------------