

MAZ



Right-of-Way Utilization Permit

Please complete a separate application for each road

Date: 4/30/2015

Applicant Name: Beverly Council Bright House

Applicant's Street Address: 3767 All American Blvd

Applicant's City, State, Zip: Orlando, Florida 32810

Telephone Number: 407-532-8605

Applicant's e-mail address: beverly.council@mybrighthouse.com

Section: 22 / Township: 24 / Range: 26

Project Road Name: Star Trail

Subdivision and/or Site Plan Name (if applicable): Node Split SL45 - 329291 (2)

Exempt
Paid Date Rec'd By

If this project will result in any new above ground structures, poles, or facilities please state where and what is proposed. Applicant may be requested to provide an engineer's certification that roadway clearance and sight distances have been met.

Description of Work: To Construct & Maintain 60' of BHN Underground Cable with (1) Directional Road Bore

Contractor: TCS Communications
Start of Construction Date: 5/27/2015
Is proposed work within city limits? no

Telephone Number: 407-523-0303
Construction duration: 7 days
If so, what city? _____

A letter of notification was mailed on 4/30/2015 to the following utilities & municipalities:

Applicant declares that he/she has determined the location of all existing underground and aerial utilities.
Applicant declares that he/she has read the attached application requirements and permit conditions.

Beverly B Council
Signature of Applicant

Beverly B Council 5/1/15
Applicant (Print Name)

Road # <u>0158</u>	To be completed by County Staff	
Permit # <u>6696</u>	Permit Fee: <u>\$100.00</u>	Fee Code: <u>PWRW</u>
Checked by: <u>Joseph Hudson</u>	Date Checked: <u>5-11-15</u>	
Approved by: <u>Ray Sa</u>	Date Approved: <u>5-11-15</u>	
Special Conditions: _____	Expiration Date: <u>5.11.16</u>	

*For inspection, call the Lake County Public Works Department at 352-483-9000
Submit Permit to: Lake County Public Works, 437 Ardice Avenue, Eustis, FL 32726*

Public Works Department
Road Operations Division

Entered Data One	<u>5.7.15</u>
First Scan	<u>"</u>
Updated Data One	<u>5-11-15</u>
Second Scan	<u>"</u>
Returned to Client	<u>2</u>

Right-of-Way Utilization Permit
Effective December 2013



Right-of-way Utilization Permit Requirements

The purpose of the Right-of-Way Utilization permit is to control the use of public rights-of-way and public easements and protect the health, safety and welfare of the public. Any work within public rights-of-way requires an approved right-of-way utilization permit.

Application Requirements:

For each road involved, please submit one (1) original application and supporting documentation to the Lake County Department of Public Works.

Completed applications must include a sketch or construction plans drawn to scale, showing the following:

1. The offset from the centerline of the right-of-way or roadway to the proposed utility installation, the road right-of-way width and pavement width, the distance from the edge of pavement to the utility, sidewalks, and the location of all other utilities, including traffic signal utilities, within the area of work.
2. One or more typical cross sections to adequately reflect the location of the utility. Please indicate the minimum vertical clearance above or below the pavement or natural ground.
3. The location of the area of work in relation to the nearest road intersection, bridges, railroad crossings, and other physical features. Please include a location or vicinity map showing the general location of the installation.

All permit applications must demonstrate that the proposed improvements conform to the right-of-way utilization requirements included in the *Lake County Land Development Regulations*.

Projects of significant length and land size may require a complete right-of-way survey.

A performance bond may be required of the applicant in the event the work covered by the right-of-way utilization permit has the potential to significantly damage the right-of-way. The amount of the performance bond shall be 110% of the estimated cost to repair such damage, as determined by Lake County.

Prior to construction, applicant shall provide written notice to all property owners adjacent to the project limits. This notice shall include, at a minimum, the anticipated construction schedule, maintenance of traffic plan and any impacts, permanent or temporary, to the adjacent properties. The notice must provide contact information including the name and telephone number of the project manager. Within a minimum of fourteen (14) calendar days prior to construction, applicant shall provide to the County a copy of the notification with a list of the parties notified.

A copy of the approved permit and related supporting documents shall be on site at all times during construction.

Permit Conditions:

Whenever necessary for the construction, maintenance, operation or alteration of the right-of-way, as determined by the County, any or all of the appurtenances authorized by this permit shall be immediately removed from the right-of-way or relocated, as required by the County, at the expense of the applicant unless reimbursement is specifically authorized.

If above ground utilities are being replaced, the old utilities and utility appurtenances must be removed from County right-of-way within thirty (30) days after new utilities are installed.

All work, materials and equipment shall meet all County codes and standards and shall be subject to inspection by the County. All right-of-way disturbed by this work shall be restored to its original condition or better and in accordance to applicable County Codes. All disturbed areas must be sodded, matching existing grass type. Bahia sod shall be used if no grass is present at time of construction.

The construction and maintenance of this utility shall not interfere with the property and rights of a prior applicant.

Where possible, excavation shall not be allowed within five (5) feet from the edge of the pavement. Situations that cannot meet this requirement shall require prior approval of the County.

The County shall be notified twenty-four (24) hours in advance of starting work. In the interest of public safety all operations shall take place during daylight hours, unless specifically authorized, and discontinued by sunset with proper signage and traffic control devices maintained during off hours.

All traffic detours shall be restricted to the limits of right-of-way with necessary flagmen and marking devices. A traffic detour or lane closure shall require specific approval by the County.

Written approval from the Lake County Engineer shall be required before any alterations to existing traffic signal equipment including, but not limited to: vehicle detection loops and signal timing.

If traffic signal vehicle detection loops are rendered inoperable, temporary detection shall be installed within twenty-four (24) hours.

All traffic signal utilities disturbed by this work shall be restored to its original condition or better. Traffic signal utilities include but not limited to: vehicle detection loops, conduit, cabling, pull boxes, pedestrian signal equipment, span assemblies, signal heads, cabinet assemblies, cameras and fiber optic infrastructure.

All utility construction and maintenance shall be performed with proper shoring, barricades, and maintenance of traffic signage in accordance with the *Manual of Uniform Traffic Control Devices*, with the regulations of Florida Industrial Safety Board, and the *Florida Department of Transportation Safety Manual*.

The County shall not be responsible for damages to any structure placed within the right-of-way. All structures shall be properly maintained, adequately visible or properly delineated to prevent damage due to normal maintenance of the right-of-way.

Open cuts of roads will not be allowed unless specifically authorized by Lake County. Directional bore or jack and bore operations should maintain a five (5) foot minimum clearance from edge of pavement on road crossing each side. Recommended bore depth is thirty-six inches (36") and a minimum bore depth is thirty inches (30"). Any overhead installations should maintain a minimum of eighteen (18) feet vertical clearance over all roadways and driveways.

This permit is effective for one year from its approval date, unless otherwise rescinded by Lake County.

Inspection and Approval of Work:

The County shall have the right to inspect and approve all materials and/or phases of work. Final inspection and acceptance of work by the County must be obtained to document the completion of the work. All work shall be subject to the construction requirements and inspections as required in other provisions of the *Lake County Land Development Regulations*. Pursuant to Section 337.403(1), Florida Statutes, any utility placed upon, under, over, or along any public road or publicly owned rail corridor that is found by Lake County to be unreasonably interfering in any way with the convenient, safe, or

continuous use, or maintenance, improvement, extension, or expansion, of such public road or publicly owned rail corridor shall, upon thirty (30) days written notice to the utility or its agent by Lake County be removed or relocated by such utility at its own expense.

It is agreed that in the event the installation, adjustment or relocation of said utilities are scheduled to be done simultaneously with Lake County construction work, the applicant shall coordinate with Lake County before proceeding and shall cooperate with the Lake County's contractor to arrange the sequence of work so as not to delay the work of Lake County contractor, defend any legal claims of Lake County's contractor due to delays caused by the applicant's failure to comply with the approved schedule, and shall comply with all provisions of the law and Lake County's current *Utility Accommodation Manual*. The applicant shall not be responsible for delay beyond its control.

All right-of-way utilization activities shall be reported to Sunshine State One-Call at least seventy-two (72) hours prior to commencement.

Guarantee and Responsibility for Compliance:

In the case of noncompliance with the County's requirements, this permit will be void and the facility will be brought into compliance or removed from the right-of-way at no cost to the County.

The County may issue "Stop Work" order(s) upon any permittee committing or creating an unsafe act which may create a public hazard or who is not complying with this permit or the applicable codes. The order shall remain in effect until such time as these matters are corrected.

Permits shall be issued with the understanding that the applicant shall guarantee all work performed under the terms of the permit for a period of one (1) year from the date of final inspection and acceptance of work.

Any failures shall be repaired by the applicant, at the direction of the County, within five (5) days, unless the urgency of the problem requires a quicker reaction time.

The applicant shall be responsible for all repair costs incurred due to damages to existing utilities by failure to use due care, including errors in locating existing utilities during construction.

Removal/Relocation of Improvements: Upon ten (10) days written notice, the applicant shall be required to remove and/or relocate the improvements placed within the right-of-way at the applicant's sole expense.

It is expressly stipulated that this permit is a license for permissive use only and that the placing of facilities upon public property pursuant to this permit shall not operate to create or vest any property right in said holder.

It is understood and agreed that the rights and privileges herein set out are granted only to the extent of the County's right, title and interest in the land to be entered upon and used by the holder, and the holder will, at all times, assume all risk of and indemnify, defend and save harmless the County of Lake from and against any and all loss, damage, cost or expense arising in any manner on account of the exercise or attempted exercises by said holder of the aforesaid rights and privileges.

I have read and understand the above requirements

Beverly B. Council 5/1/15
Applicant's Signature/Date

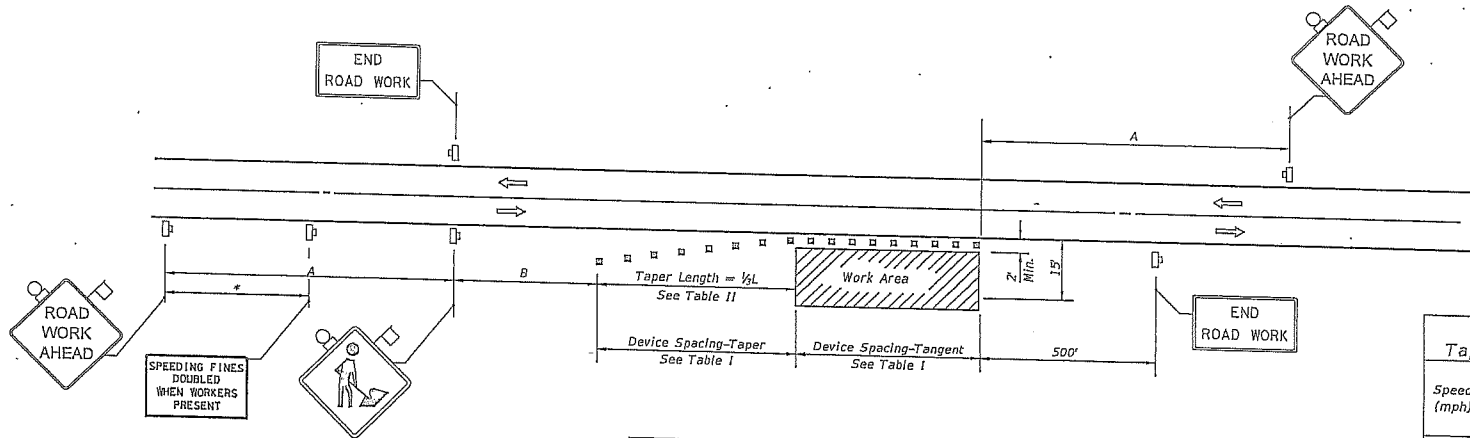

Speed	Spacing (ft.)	
	A	B
40 mph or less	200	200
45 mph	350	350
50 mph or greater	500	500

*Midway between signs.

Speed (mph)	Max. Distance Between Devices (ft.)			
	Cones or Tubular Markers		Type I or Type II Barricades or Vertical Panels or Drums	
	Taper	Tangent	Taper	Tangent
25	25	50	25	50
30 to 45	25	50	30	50
50 to 70	25	50	50	100

Speed (mph)	1/2 L (ft)			Notes
	8' Shldr.	10' Shldr.	12' Shldr.	
25	28	35	42	L = WS* 60
30	40	50	60	
35	55	68	82	
40	72	90	107	L = WS
45	120	150	180	
50	133	167	200	
55	147	183	220	
60	160	200	240	
65	173	217	260	
70	187	233	280	

8' minimum shoulder width

1/2 L = Length of shoulder taper in feet

W = Width of total shoulder in feet (combined paved and unpaved width)

S = Posted speed limit (mph)

- SYMBOLS**
- Work Area
 - Sign With 18" x 18" (Min.) Orange Flag And Type B Light
 - Channelizing Device (See Index No. 600)
 - Work Zone Sign
 - Lane Identification + Direction of Traffic

- GENERAL NOTES**
- When four or more work vehicles enter the through traffic lanes in a one hour period or less (excluding establishing and terminating the work area), the advanced FLAGGER sign shall be substituted for the WORKERS sign. For location of flaggers and FLAGGER signs, see Index No. 603.
 - SHOULDER WORK sign may be used as an alternate to the WORKER symbol sign only on the side where the shoulder work is being performed.
 - When a side road intersects the highway within the TTC zone, additional TTC devices shall be placed in accordance with other applicable TCZ Indexes.
 - For general TCZ requirements and additional information, refer to Index No. 600.

- DURATION NOTES**
- Signs and channelizing devices may be omitted if all of the following conditions are met:
 - Work operations are 60 minutes or less.
 - Vehicles in the work area have high-intensity, rotating, flashing, oscillating, or strobe lights operating.

CONDITIONS
WHERE ANY VEHICLE, EQUIPMENT, WORKERS OR THEIR ACTIVITIES ENCROACH THE AREA CLOSER THAN 15' BUT NOT CLOSER THAN 2' TO THE EDGE OF TRAVEL WAY.

5/20/2014 4:58:11 PM

LAST REVISION 07/01/12	REVISION	DESCRIPTION:	2015 DESIGN STANDARDS	TWO-LANE, TWO-WAY, WORK ON SHOULDER	INDEX NO. 602	SHEET NO. 1 of 1
---------------------------	----------	--------------	--------------------------	-------------------------------------	------------------	---------------------

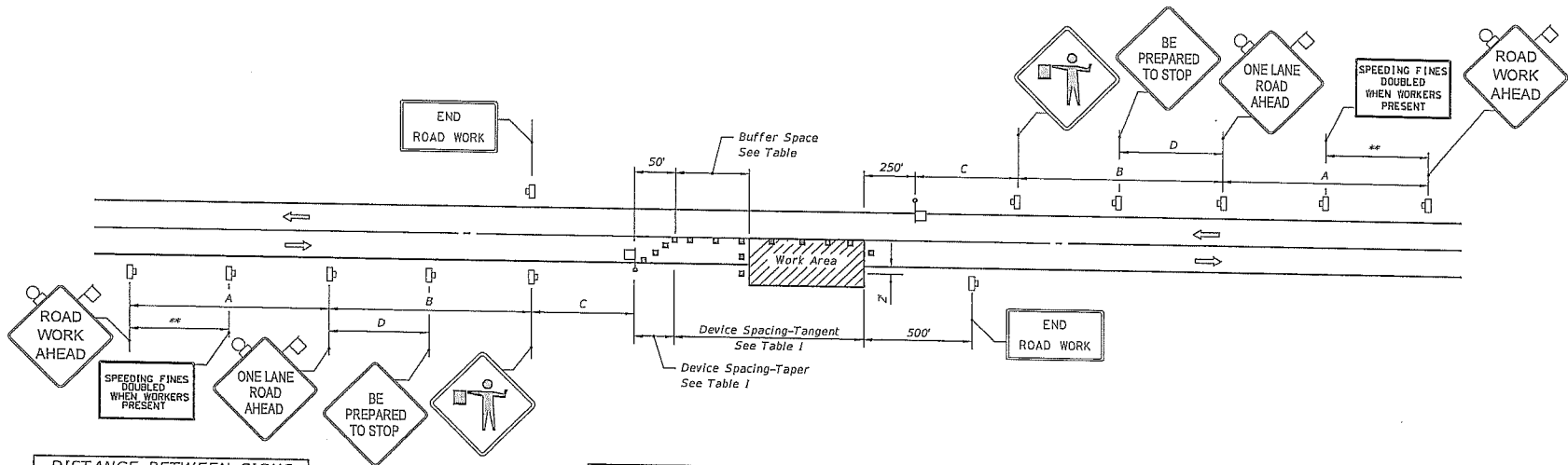

DISTANCE BETWEEN SIGNS				
Speed (mph)	Spacing (ft.)			
	A	B	C	D
40 or less	200	200	200	100
45	350	350	350	175
50	500	500	500	250
55 or greater	2640	1640	1000	500

* The ROAD WORK 1 MILE sign may be used as an alternate to the ROAD WORK AHEAD sign.

** 500' beyond the ROAD WORK AHEAD sign or midway between signs whichever is less.

*** BE PREPARED TO STOP sign may be omitted for speeds of 45 MPH or less.

SYMBOLS

- Work Area
- Sign With 18" x 18" (Min.) Orange Flag And Type B Light
- Channelizing Device (See Index No. 600)
- Work Zone Sign
- Flagger
- Automated Flagger Assistance Devices (AFAD), With Gate
- Lane Identification + Direction of Traffic

TABLE I DEVICE SPACING				
Speed (mph)	Max. Distance Between Devices (ft.)			
	Cones or Tubular Markers		Type I or Type II Barricades or Vertical Panels or Drums	
	Taper	Tangent	Taper	Tangent
25 to 45	20	50	20	50
50 to 70	20	50	20	100

GENERAL NOTES

- Work operations shall be confined to one traffic lane, leaving the opposite lane open to traffic.
- Additional one-way control may be effected by the following means:
 - Flag-carrying vehicle;
 - Official vehicle;
 - Pilot vehicles;
 - Traffic signals.

When flaggers are the sole means of one-way control, the flaggers shall be in sight of each other or in direct communication at all times.
- The ONE-LANE ROAD signs are to be fully covered and the FLAGGER signs either removed or fully covered when no work is being performed and the highway is open to two-way traffic.
- When a side road intersects the highway within the TTC zone, additional TTC devices shall be placed in accordance with other applicable TCZ Indexes.
- The two channelizing devices directly in front of the work area and the one channelizing device directly at the end of the work area may be omitted provided vehicles in the work area have high-intensity rotating, flashing, oscillating, or strobe lights operating.
- For Temporary Raised Rumble Strips, general TCZ requirements and additional information, refer to Index No. 600.

DURATION NOTES

- ROAD WORK AHEAD and the BE PREPARED TO STOP signs may be omitted if all of the following conditions are met:
 - Work operations are 60 minutes or less.
 - Speed limit is 45 mph or less.
 - No sight obstructions to vehicles approaching the work area for a distance equal to the buffer space.
 - Vehicles in the work area have high-intensity, rotating, flashing, oscillating, or strobe lights operating.
 - Volume and complexity of the roadway has been considered.

BUFFER SPACE	
Speed (mph)	Dist. (ft.)
25	155
30	200
35	250
40	305
45	360
50	425
55	495
60	570
65	645
70	730

When Buffer Space cannot be attained due to geometric constraints, the greatest attainable length shall be used, but not less than 200 ft.

CONDITIONS

WHERE ANY VEHICLE, EQUIPMENT, WORKERS OR THEIR ACTIVITIES ENCROACH THE AREA BETWEEN THE CENTERLINE AND A LINE 2' OUTSIDE THE EDGE OF TRAVEL WAY.

07/01/2014 5:17:38 PM

LAST REVISION 07/01/14	REVISION	DESCRIPTION:	2015 FDOT DESIGN STANDARDS	TWO-LANE, TWO-WAY, WORK WITHIN THE TRAVEL WAY	INDEX NO. 603	SHEET NO. 1 of 2
---------------------------	----------	--------------	-------------------------------	--	------------------	---------------------

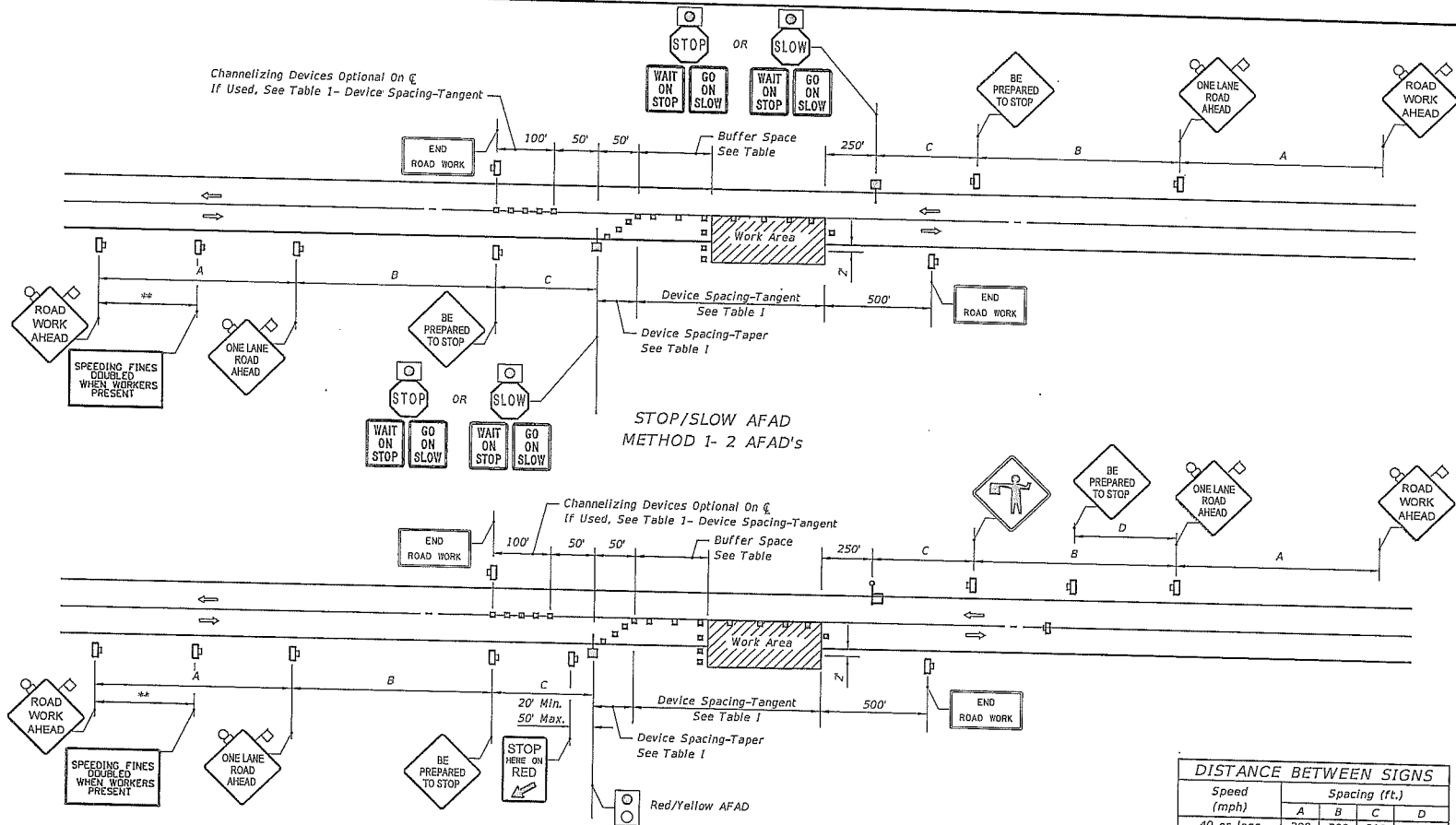

Speed (mph)	Spacing (ft.)			
	A	B	C	D
40 or less	200	200	200	100
45	350	350	350	175
50	500	500	500	250
55 or greater	2640	1640	1000	500

*(See Sheet 1 Notes)
 **(See Sheet 1 Notes)

**RED/YELLOW AFAD
 METHOD 2- 1 AFAD AND A FLAGGER**

AUTOMATED FLAGGER ASSISTANCE DEVICES (AFAD) NOTES

1. AFAD's shall only be used in situations where there is only one lane of approaching traffic in the direction to be controlled.
 2. When used at nighttime, the AFAD flagging station shall be illuminated.
 3. When the AFAD is not in use, it shall be moved outside the clear zone or be shielded by a barrier or crash cushion and the signs associated with the AFAD shall be removed or covered.
 4. Duration Notes shown on sheet 1 of 2 do not apply when AFAD are used.
 5. Only qualified flaggers who have been trained in the operation of the AFAD may operate the AFAD. When in use, each AFAD must be in view of and attended at all times by the flagger operating the device. Use two flaggers and one of the following methods in the deployment of AFAD:
 Method 1: Place an AFAD at each end of the temporary traffic control zone.
 Method 2: Place an AFAD at one end of the temporary traffic control zone and a flagger at the opposite end.
- A single flagger may simultaneously operate two AFAD (Method 1) or may operate a single AFAD on one end of the temporary traffic control zone while being the flagger at the opposite end of the temporary traffic control zone (Method 2) if all four of the following conditions are present:
 a. The flagger has an unobstructed view of the AFAD(s);
 b. The flagger has an unobstructed view of approaching traffic in both directions; and
 c. For Method 1, the AFAD's are less than 800 ft apart. For Method 2, the AFAD and the flagger are less than 800 ft apart.
 d. Ensure two trained flaggers are available on-site to provide normal flagging operations should an AFAD malfunction.

S1728 PH

LAST REVISION 07/01/10	DESCRIPTION:	FDOT 2015 DESIGN STANDARDS	TWO-LANE, TWO-WAY, WORK WITHIN THE TRAVEL WAY	INDEX NO. 603	SHEET NO. 2 of 2
---------------------------	--------------	----------------------------------	--	------------------	---------------------

Typical Underground Cross View of Roadway Bore

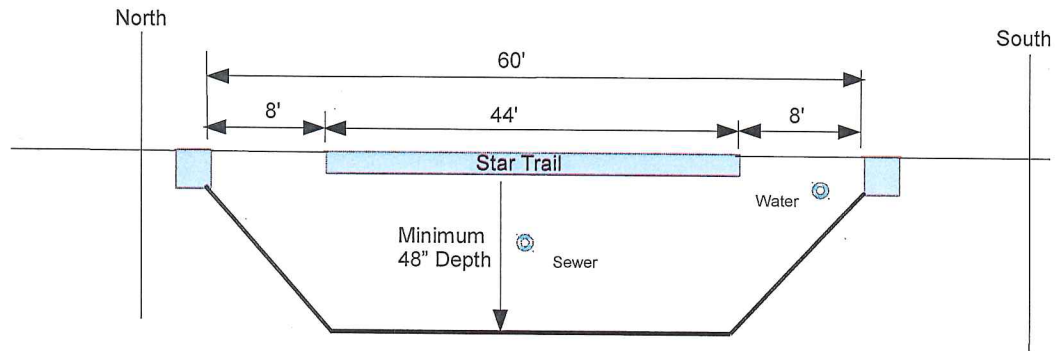

Proposed CATV route (2) 1 1/4" HDPE Pipe
Casing to extend eight (8) feet beyond edge of Pavement
Section 22 Township 24 Range 26
Proposed Road Bore Crossing: Star Trail
Utility locations are from Edge of Pavement

"ALL UTILITIES TO BE LOCATED AND VERIFIED BEFORE CONSTRUCTION"



BrightHouse Networks -- Node Split - SL45 - Carl # 329291

Proposed BHN Cable Route on Greater Groves Blvd

Section 22 Township 24 Range 26



60' Directional Road Bore

