

# Hancock Commons

## Lake County, Florida

### PCI# 7009

### Sheet Index

Prepared By:  
 Patel Consultants, Inc.  
 2826 Safe Harbor Drive  
 Tampa, Florida 33618  
 Phone: (813) 932-2875  
 Fax: (813) 933-9002

Prepared For:  
 Trycon Associates  
 951 Market Promenade Avenue,  
 Suite #2105  
 Lake Mary, Florida 32746  
 Phone: (407) 804-8949  
 Fax: (407) 804-8963

PC-1	COVER SHEET
PC-2	CONSTRUCTION NOTES
PC-3	ANCHOR BLOCK DETAILS
PC-4 THROUGH PC-6	RETAINING WALL #1
PC-7	RETAINING WALL #2
PC-8	CROSS SECTIONS
PC-9	PIPE SADDLE DETAILS
*SHEET C-4 & C-5	GRADING AND DRAINAGE PLANS

**FINAL PERMITTED PLANS**  
 DATE 5/29/07  
 INITIAL (Raj)

**FINAL PERMITTED PLANS**  
 DATE \_\_\_\_\_  
 INITIAL \_\_\_\_\_

67971-2X  
 RECEIVED  
 MAY 04 2007  
 PDS  
 ALTAMONTE SVC. CTR.

\*PLANS OBTAINED FROM KELLY, COLLINS & GENTRY, INC.

<b>PATEL CONSULTANTS, INC.</b>			
<small>2826 Safe Harbor Drive, Tampa, Florida 33618 Tel: (813) 932-2875 Service through Excellence</small>			
<small>Babu I. Patel, P.E. Florida Reg. # 20941 Certificate of Authorization # 9288</small>	<small>PROJECT</small>	<b>HANCOCK COMMONS LAKE COUNTY, FLORIDA</b>	
<small>SEAL</small> <i>BIP 5/29/07</i>	<small>TITLE</small>	COVER SHEET PCI# 7009	
<small>DRAWN</small> JRS 1-30-07	<small>SCALE</small>	NONE	<small>REV</small> 0
<small>APPROVED</small>			<small>SHEET</small> PC - 1

Hancock Commons, Clermont, FL  
PCI Project No. 7009

January 28, 2007

**DESIGN CRITERIA:**

- THIS DESIGN IS BASED ON NATIONAL CONCRETE MASONRY ASSOCIATION HYPOTHESIS FOR SR WALLS AND FLORIDA BUILDING CODE 2004 (WITH 2006 AMENDMENTS).
- LIVE LOAD SURCHARGE USED FOR THE DESIGN IS 250 POUNDS PER SQUARE FOOT (FOR THE ROADWAY), AT THE TOP OF THE WALL.
- GUARDS TO BE INSTALLED BY OWNER TO MEET ALL LOCAL AND FLORIDA BUILDING CODE 2004, SECTION 1012. REINFORCED CONCRETE SUPPORT IS PROVIDED FOR HAND RAIL INSTALLATION.
- REINFORCED CONCRETE SUPPORT IS PROVIDED FOR FLORIDA D.O.T. GUARD RAIL INSTALLATION.
- SUB-SURFACE WORK (AS RECOMMENDED BY ANDREYEV ENGINEERING, INC.) SHALL BE PERFORMED UNDER SUPERVISION BY QUALIFIED SOIL CONSULTANT. FOUNDATION SOIL SHALL BE PREPARED TO MEET OR EXCEED ALLOWABLE BEARING CAPACITY OF 2500 PSF.
- CONCRETE STRUCTURAL DESIGN IS BASED ON ACI - 318 AND CONSTRUCTION SHALL CONFORM TO ACI - 301 (LATEST EDITIONS).
- STANDARD TOLERANCES FOR CONCRETE CONSTRUCTION AND MATERIALS PER ACI 117.
- ALL CONSTRUCTION PROCEDURES SHALL MEET THE REQUIREMENTS OF OSHA AND OTHER LOCAL, STATE AND FEDERAL AGENCIES, TO PROTECT PERSONNEL AND EXISTING STRUCTURES.
- WALL DIMENSIONS SHOWN HERE SUPERCEDES ALL OTHER DRAWINGS.
- QUANTITY OF RETAINING WALL AS SHOWN IN THESE PLANS MAY BE INCREASED OR DECREASED (BASED ON CONSTRUCTION PROCEDURES AND ACTUAL SITE CONDITIONS), AT THE DIRECTION OF THE ARCHITECT / ENGINEER.

**CONSTRUCTION:**

THE CONTRACTOR INSTALLING THIS WALL MUST BE AN APPROVED / CERTIFIED ANCHOR WALL CONTRACTOR. THE SELECTED WALL CONTRACTOR SHALL HAVE A MINIMUM OF 500,000 SQUARE FEET OF SEGMENTAL RETAINING WALL INSTALLATION EXPERIENCE WITHIN LAST 3 YEARS. THIS EXPERIENCE MUST BE COMPRISED OF PROJECTS WITH SIMILAR SIZE AND SCOPE.

ASSOCIATED CONSTRUCTION PRODUCTS (ACP) MEETS THIS QUALIFICATION.  
ORLANDO OFFICE PHONE: 407-671-7444  
TAMPA OFFICE PHONE: 813-973-4425

**MATERIAL SPECIFICATIONS:**

GEOGRID SOIL REINFORCEMENT SHALL BE MIRAGRID 5 XT, AS MANUFACTURED BY NICOLON MIRAFI GROUP, GEOGRID SHALL BE INSTALLED IN ACCORDANCE WITH MANUFACTURERS PRINTED INSTRUCTIONS.

CONCRETE MASONRY UNITS SHALL BE ANCHOR WALL SYSTEM UNITS AS MANUFACTURED BY ANCHOR BLOCK OF FLORIDA, INC. UNITS SHALL BE 8" VERTICA (WITH 2 DEGREE BATTER). ANCHOR WALL UNITS SHALL BE INSTALLED IN ACCORDANCE WITH MANUFACTURERS PRINTED INSTRUCTIONS. VISTA UNITS SHALL BE 8" x 9" x 18". COMPRESSIVE STRENGTH SHALL BE A MINIMUM OF 3000 PSI. VISTA UNITS SHALL MEET ASTM C90. VISTA UNITS (ALL) CELLS SHALL BE FILLED AND CONSOLIDATED WITH 3000-PSI CONCRETE.

GUARD RAIL SUPPORT CONCRETE TO BE 4000 PSI AT 28 DAYS AND REINFORCING STEEL TO BE ASTM A-615, GRADE 60.

ALL CONCRETE SURFACES SHALL RECEIVE CURING COMPOUND IN ACCORDANCE WITH MANUFACTURERS RECOMMENDATION. CURING COMPOUND SHALL BE A LIQUID MEMBRANE - FORMING COMPOUND CONFIRMING TO ASTM A-309. THE COMPOUND SHALL BE TYPE I, CLEAR OR TRANSLUCENT, AND SHALL CONTAIN A FUGITIVE DYE.

**CONCRETE PLACEMENT:**

MINIMUM TWO CYLINDERS SHALL BE TAKEN AT "EACH POUR". THESE TWO SHALL BE TESTED AT TWENTY-EIGHT DAYS. AVERAGE OF TWO CYLINDERS SHALL BE THE STRENGTH OF THE CONCRETE.

**FOUNDATION:**

ALL UNSUITABLE MATERIAL SUCH AS MUCK SHALL BE REMOVED FROM UNDERNEATH AS REQUIRED. STRUCTURAL FILL SHALL BE COMPACTED TO 95% OF THE MODIFIED PROCTOR, MAXIMUM DRY DENSITY (ASTM D-1557). FOUNDATION AREA SHALL BE DEWATERED PRIOR TO FOUNDATION CONSTRUCTION.

**DRAINAGE FILL:**

DRAINAGE FILL SHALL BE FREE DRAINING CRUSHED STONE, 3/8" TO 3/4." IT SHALL MEET THE AASHTO #57 OR #67 STONE

**FILTER FABRIC:**

FILTER FABRIC SHALL BE 6 OZ. NON-WOVEN GEOTEXTILE. PROVIDE 12 INCH LAP @ VERTICAL JOINTS AND 2 INCHES TURNING @ EACH LAYER OF GEOGRID. EXTEND FILTER FABRIC 18" BEYOND JOINT WITH EXISTING STRUCTURES AND WRAP IT WITH EXISTING STRUCTURE.

**BACKFILL MATERIAL:**

BACKFILL MATERIAL SHALL BE CLEAN FREE DRAINING SAND WITH 10% OR LESS FINES. SAND FRICTION ANGLE SHALL BE 30 DEGREES MINIMUM. THIS MATERIAL SHALL BE APPROVED BY SOIL CONSULTANT TO INSURE THAT IT MEETS THESE CRITERIA.

**ANCHOR WALL UNIT INSTALLATION:**

INSURE THAT UNITS ARE IN FULL CONTACT WITH BASE. FILL ALL VOIDS AT UNITS WITH DRAINAGE FILL MATERIAL. TEMP FILL. SWEEP ALL EXCESS MATERIAL FROM TOP OF UNITS AND INSTALL NEXT COURSE. INSURE THAT EACH COURSE IS COMPLETELY FILLED WITH CRUSHED STONE.

PULL THE UNITS FORWARD UNTIL THE LOCATING SURFACE OF THE UNIT CONTACTS THE LOCATING SURFACE OF THE UNITS IN THE PRECEDING COURSE. PULL THE UNIT FORWARD AS FAR AS POSSIBLE.

**GEOGRID INSTALLATION:**

THE GEOGRID SOIL REINFORCEMENT SHALL BE LAID HORIZONTALLY ON TOP OF THE ANCHOR WALL UNIT AND HORIZONTALLY ON COMPACTED BACK FILL.

PULL TAUT AND ANCHOR BEFORE PLACING BACKFILL ON THE GEOGRID. CORRECT ORIENTATION (ROLL DIRECTION) OF THE GEOGRID SHALL BE VERIFIED BY THE CONTRACTOR.

**FILL PLACEMENT:**

BACKFILL MATERIAL SHALL BE PLACED IN 12 INCH LIFTS AND COMPACTED TO 95% OF THE MODIFIED PROCTOR MAXIMUM DRY DENSITY (ASTM D - 1557). VIBRATORY PLATE COMPACTOR SUCH AS "BPU 3345 A" BY WACKER CORPORATION CAN BE USED.

TESTING METHODS AND FREQUENCY, VERIFICATIONS OF MATERIAL SPECIFICATIONS AND COMPACTION SHALL BE PER SOIL CONSULTANT'S RECOMMENDATIONS.

FILTER FABRIC SHALL BE PLACED BETWEEN CRUSHED STONE AND SAND.

ONLY HAND OPERATED COMPACTION EQUIPMENT SHALL BE ALLOWED WITHIN 5 FEET OF THE BACK SURFACE OF THE ANCHOR UNITS. HEAVY CONSTRUCTION EQUIPMENT SHALL NOT BE ALLOWED WITHIN THIS DISTANCE. BACKFILL SHALL BE PLACED FROM THE WALL REARWARD INTO THE EMBANKMENT TO INSURE THAT THE GEOGRID REMAINS TAUT.

TRACK MOUNTED CONSTRUCTION EQUIPMENT SHALL NOT BE OPERATED DIRECTLY ON THE GEOGRID. A MINIMUM BACKFILL THICKNESS OF 6 INCHES IS REQUIRED PRIOR TO OPERATION OF TRACK MOUNTED VEHICLES OVER THE GEOGRID. TURNING OF TRACK MOUNTED VEHICLES SHOULD BE KEPT TO A MINIMUM TO PREVENT TRACKS FROM DISPLACING THE FILL AND DAMAGING THE GEOGRID.

RUBBER TIRED EQUIPMENT MAY PASS OVER THE GEOGRID AT SLOW SPEED, LESS THAN 10 MPH. SUDDEN BRAKING AND SHARP TURNING SHALL BE AVOIDED.

**CONSTRUCTION TOLERANCES:**

VERTICAL CONTROL:  
± 1.25 INCHES OVER A 10 FOOT DISTANCE

HORIZONTAL LOCATION CONTROL:  
STRAIGHT LINES: ± 1.25 INCHES OVER A 10-FOOT DISTANCE  
STRAIGHT AND RADIUS CORNER LOCATION: ± 1.0 FOOT  
CURVES AND SERPENTINE RADIUS: ± 2.0 FOOT

ROTATION:  
FROM ESTABLISHED PLAN WALL BATTER: 2.0 DEGREES  
MAXIMUM, ± 10% FROM TOTAL ESTABLISHED HORIZONTAL SETBACK

BULGING:  
1.25 INCH OVER A 10 FOOT DISTANCE

**TREE PLANTING:**

CONTACT WALL INSTALLER PRIOR TO PLANTING ANY LANDSCAPING ADJACENT TO WALL, TO AVOID DAMAGE TO THE GEOGRID.

**WALL LAYOUT:**

THE GENERAL CONTRACTOR IS RESPONSIBLE FOR THE LOCATION OF THE WALL AND SHALL LOCATE THE WALL PRIOR TO START OF THE CONSTRUCTION.

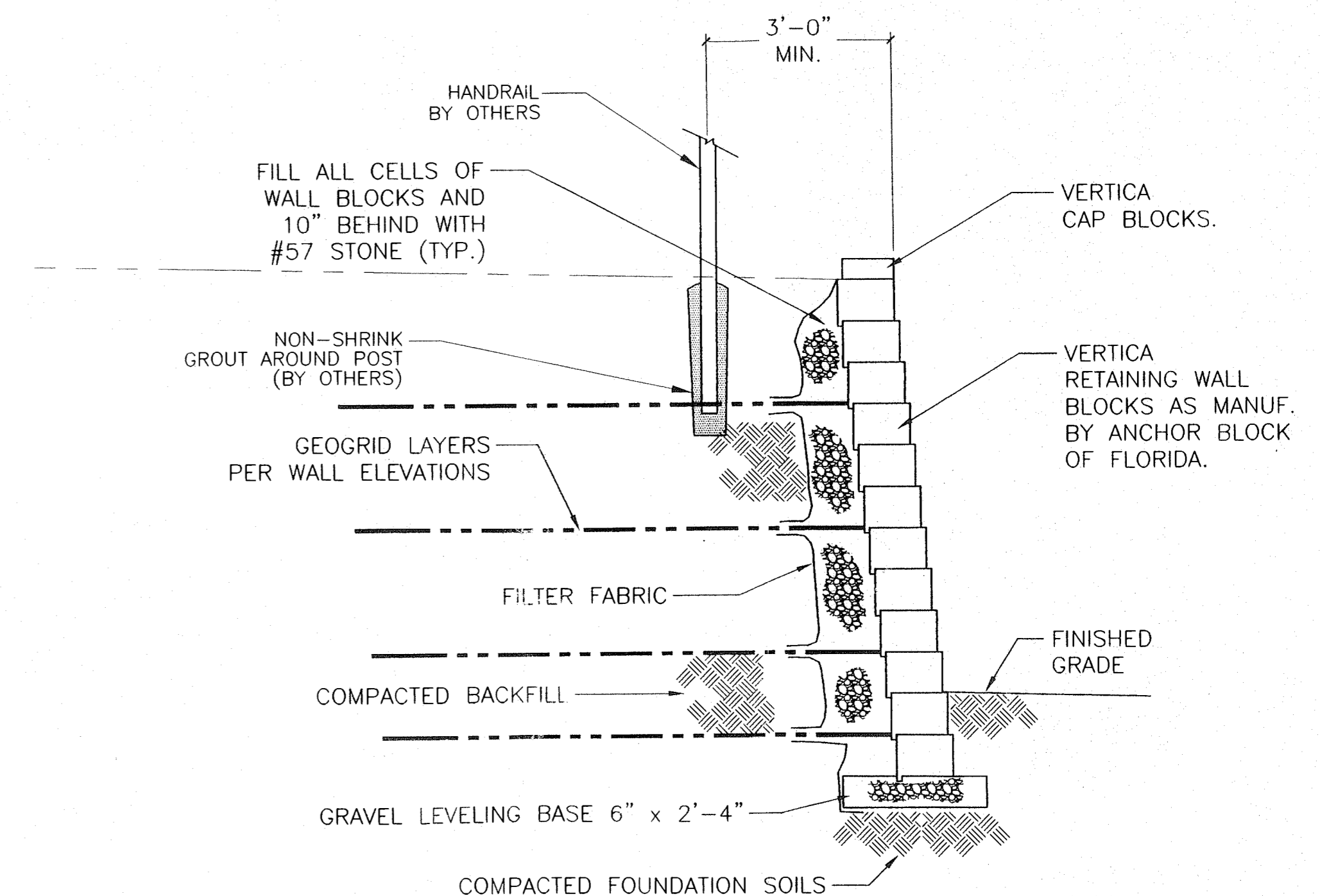

**CROSS SECTION**  
RETAINING WALL  
WITH FENCE OR HANDRAIL

<b>PATEL CONSULTANTS, INC.</b>			
2826 Safe Harbor Drive, Tampa, Florida 33618 Tel: (813) 932-2875 Service through Excellence			
Babu I. Patel, P.E. Florida Reg. # 20941 Certificate of Authorization # 9288	PROJECT	HANCOCK COMMONS LAKE COUNTY, FLORIDA	
SEAL	TITLE	CONSTRUCTION NOTES PCI# 7009	
BIP 11/31/07	DRAWN JRS 1-30-07	SCALE NONE	REV 0
APPROVED			SHEET PC - 2

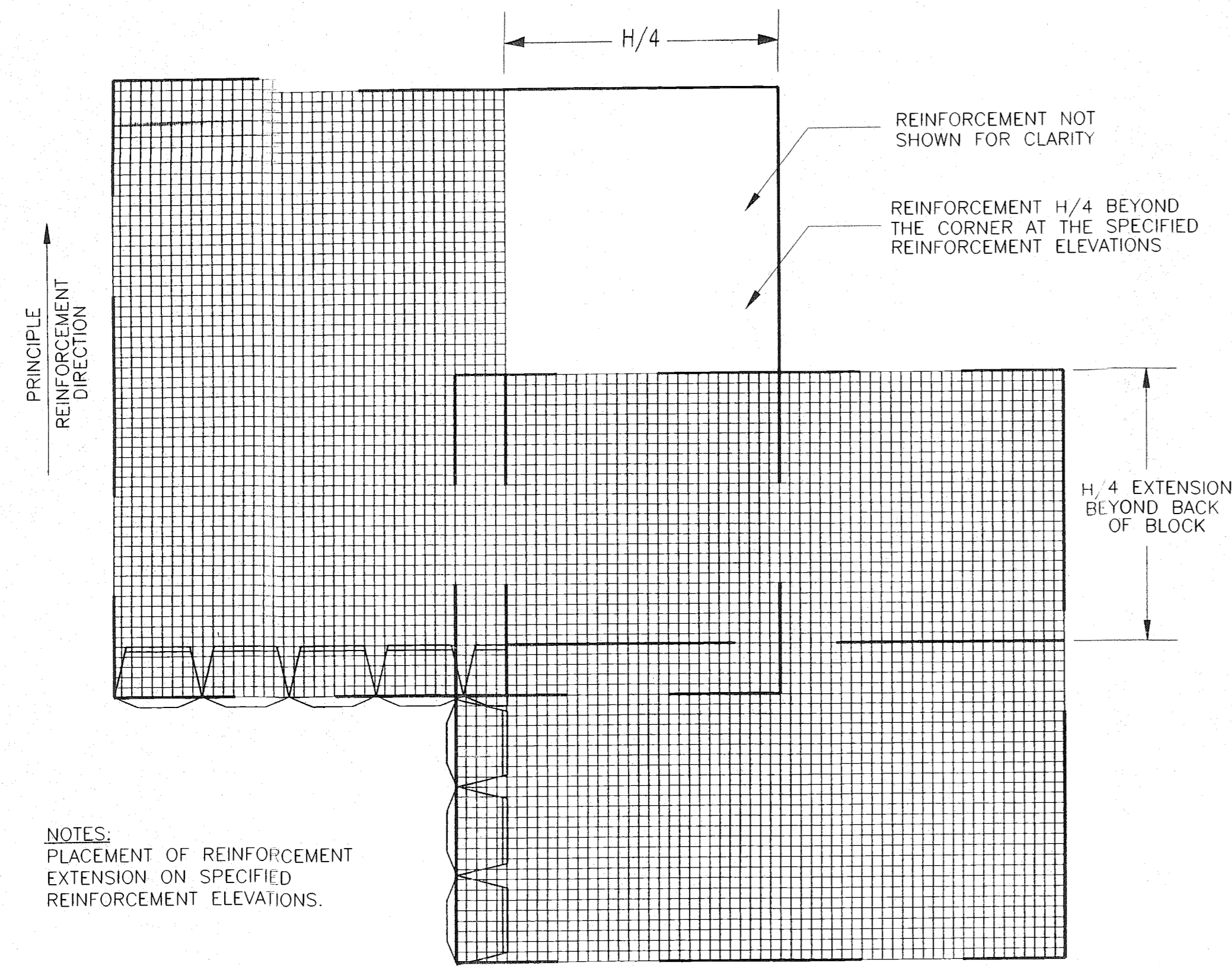

NOTES:  
PLACEMENT OF REINFORCEMENT  
EXTENSION ON SPECIFIED  
REINFORCEMENT ELEVATIONS.

**GEOGRID REINFORCEMENT @ INSIDE CORNERS**  
(NOT TO SCALE)

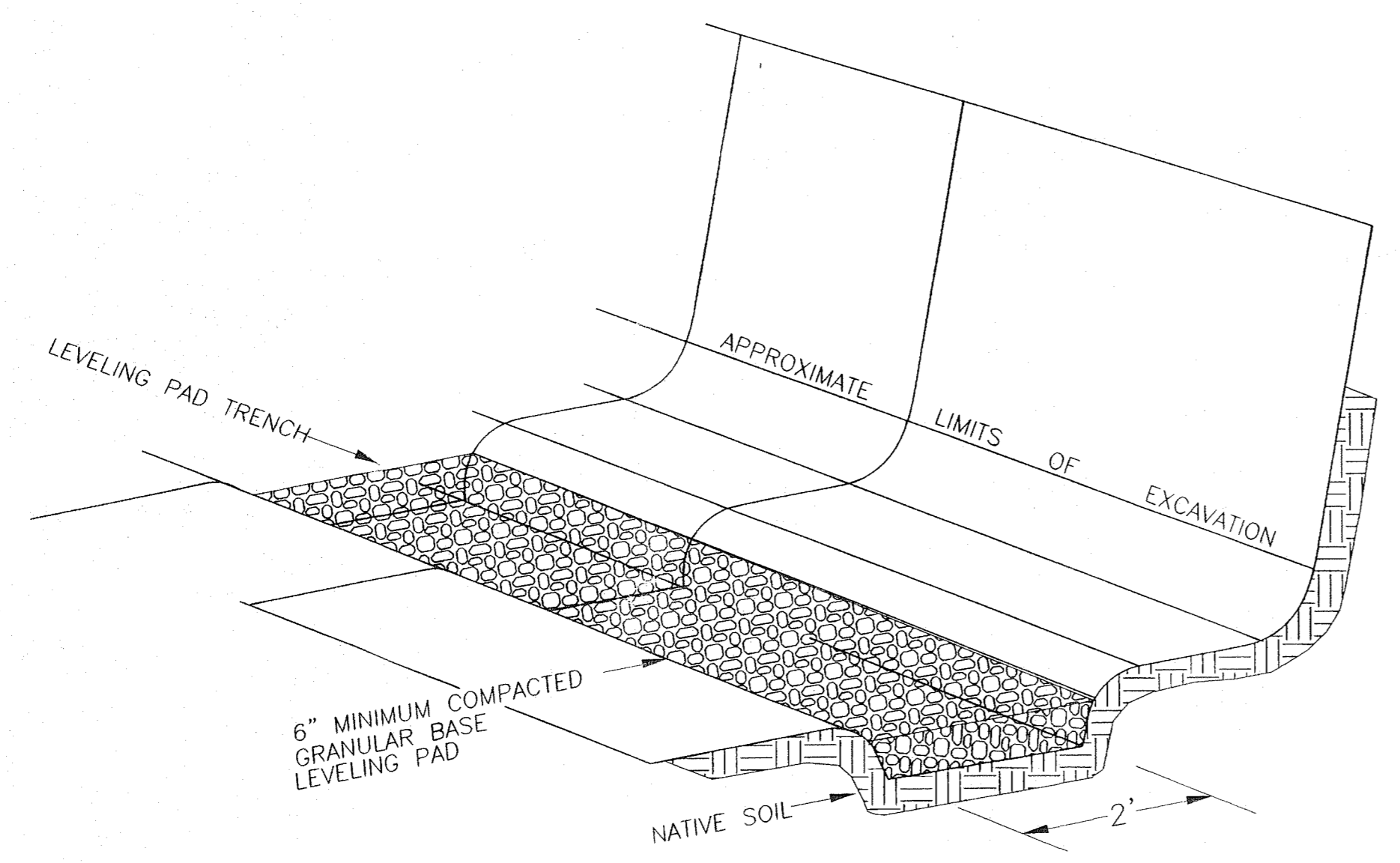

**LEVELING PAD/FOOTER DETAIL**  
(NOT TO SCALE)

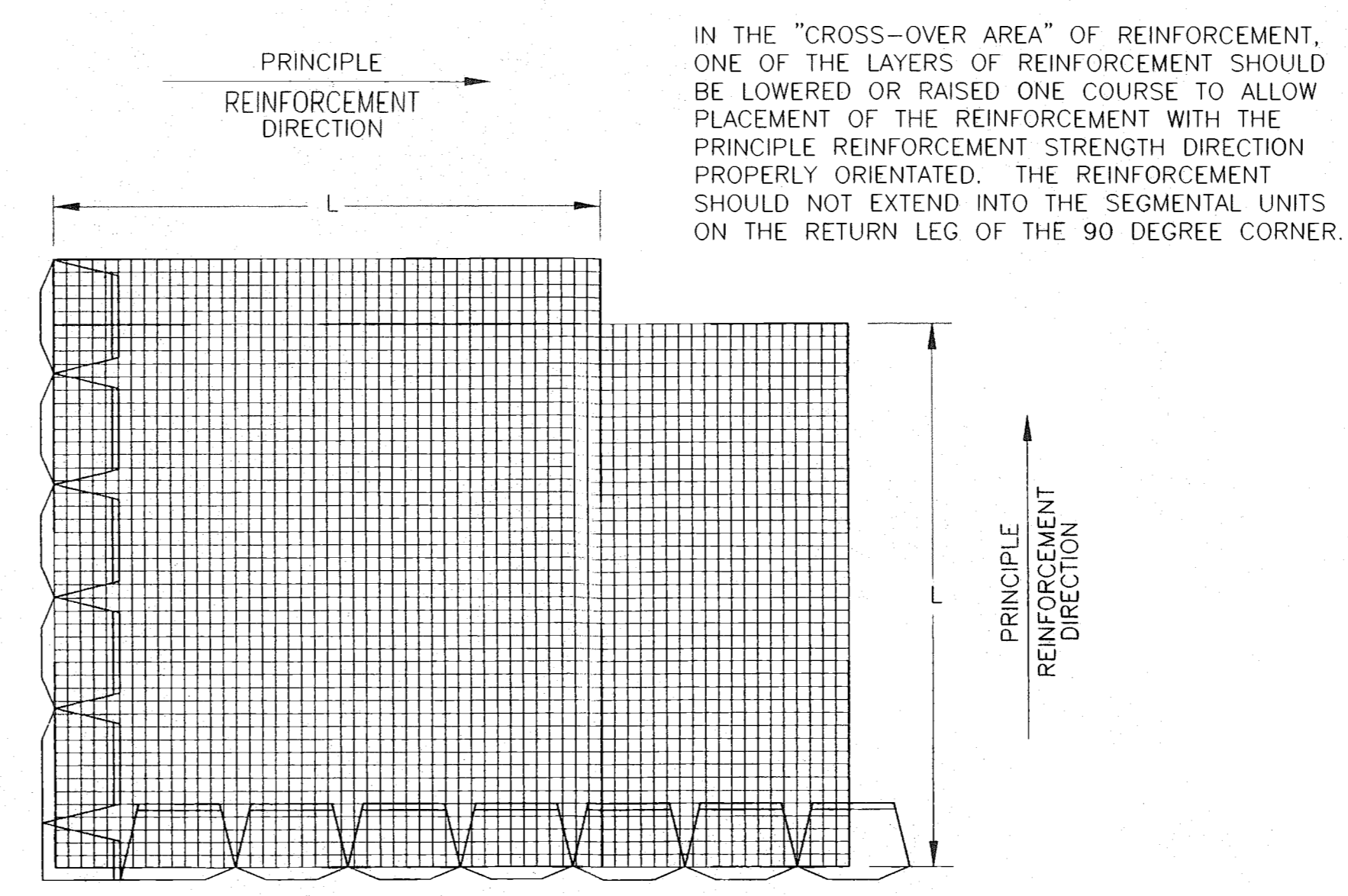

**GEOGRID REINFORCEMENT @ OUTSIDE CORNERS**  
(NOT TO SCALE)

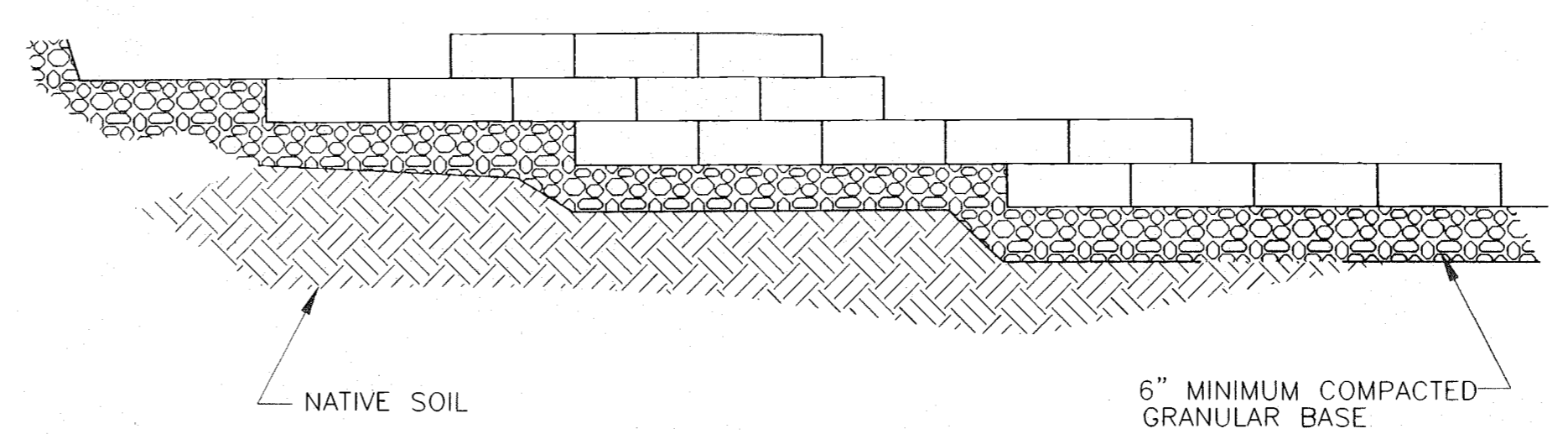

**TYPICAL FOOTER STEP-UP DETAIL**  
(NOT TO SCALE)

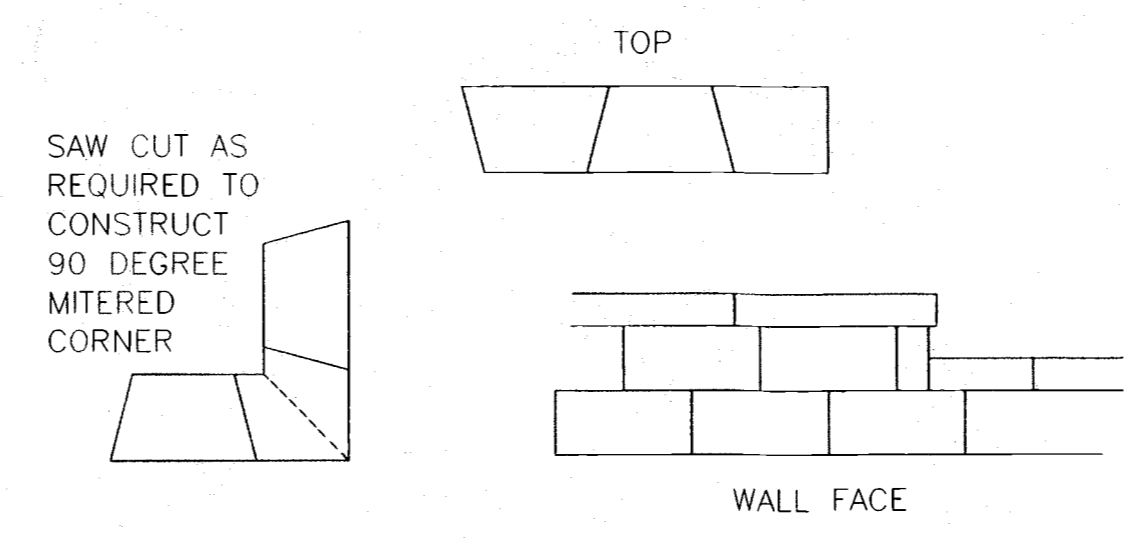

1. ALWAYS START CAPPING WALL FROM THE LOWEST ELEVATION.
2. LAYOUT CAPS PRIOR TO USING ADHESIVE.
3. CUT CAPS TO FIT. VARIOUS COMBINATIONS OF LONG AND SHORT CAP FACES WILL BE NECESSARY FOR RADII GREATER THAN THE MINIMUM.
4. ALTERNATE SHORT AND LONG CAP FACES EVERY OTHER CAP TO ACHIEVE A STRAIGHT ROW OF CAPS.
5. USE EXTERIOR-GRADE CONSTRUCTION ADHESIVE TO SECURE CAPS.
6. THE SPLIT FACE OF THE VERTICA CAP TO HAVE A 1" NOMINAL OVERHANGE OR EYEBROW.

**TYPICAL VERTICA CAP DETAIL**  
(NOT TO SCALE)

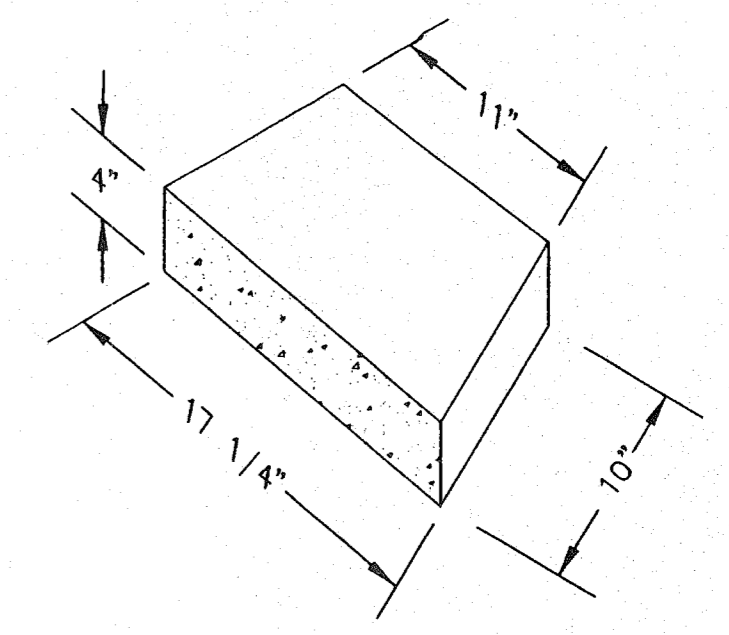

**ANCHOR VERTICA CAP UNIT**  
3-D VIEW  
(NOT TO SCALE)

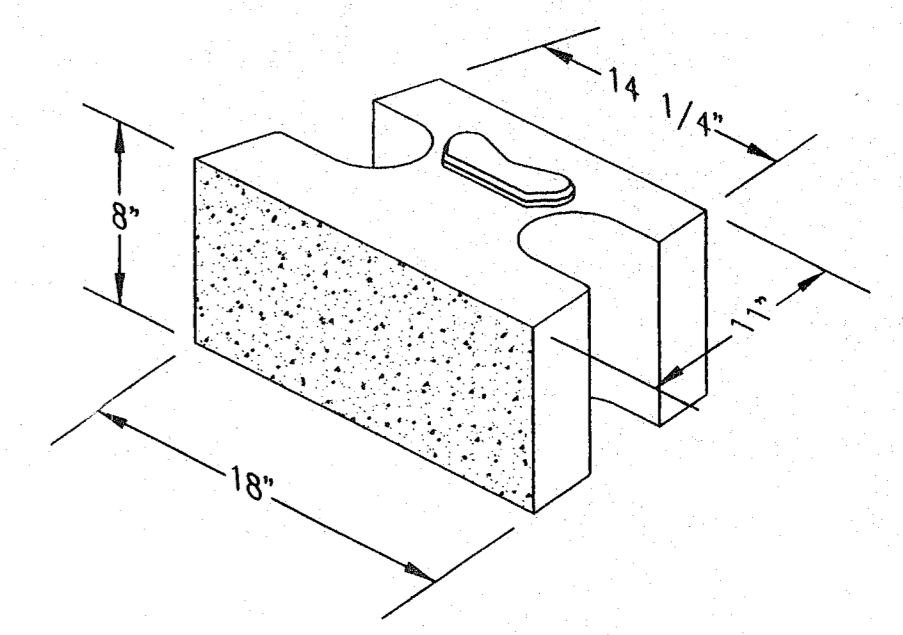

**ANCHOR VERTICA STRAIGHT UNIT**  
3-D VIEW  
(NOT TO SCALE)

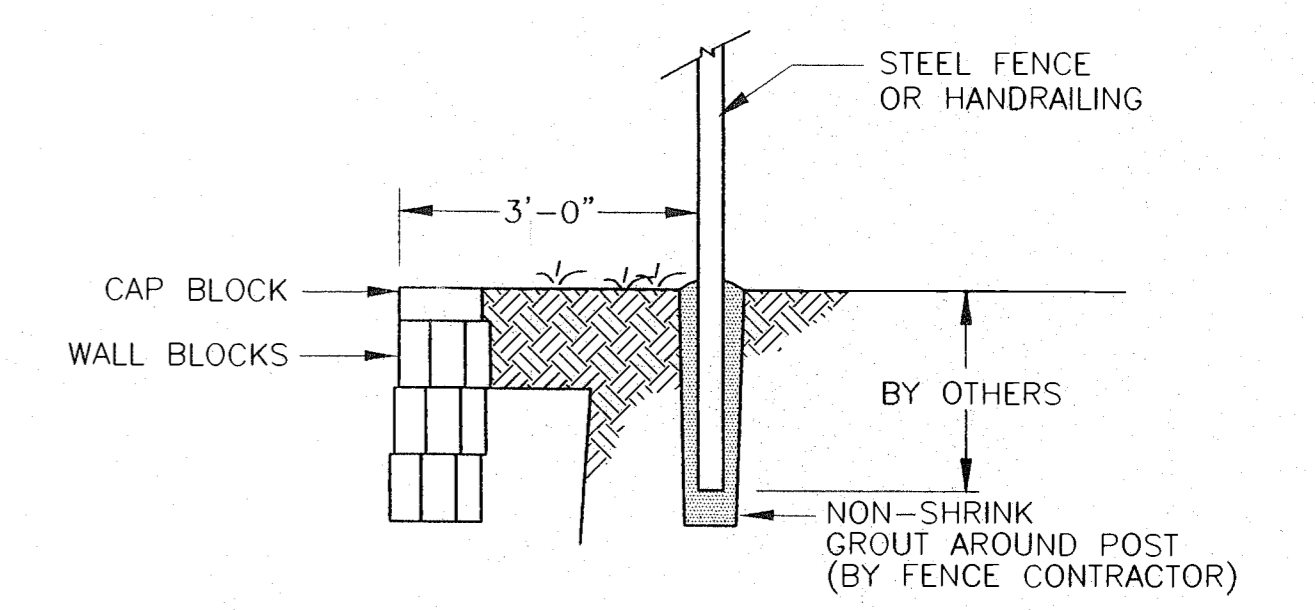

**FENCE POST INSTALLATION DETAIL**  
(NOT TO SCALE)

<b>PATEL CONSULTANTS, INC.</b>			
<small>2826 Safe Harbor Drive, Tampa, Florida 33618 Tel: (813) 932-2875 Service through Excellence</small>			
<small>Babu I. Patel, P.E. Florida Reg. # 20941 Certificate of Authorization # 9288</small>  <small>BIP</small> <small>1/31/07</small>	PROJECT <b>HANCOCK COMMONS LAKE COUNTY, FLORIDA</b>		
	TITLE <b>ANCHOR BLOCK DETAILS PCI# 7009</b>		
DRAWN <b>JRS</b> APPROVED	SCALE 1-30-07 NONE	REV <b>0</b>	SHEET <b>PC - 3</b>

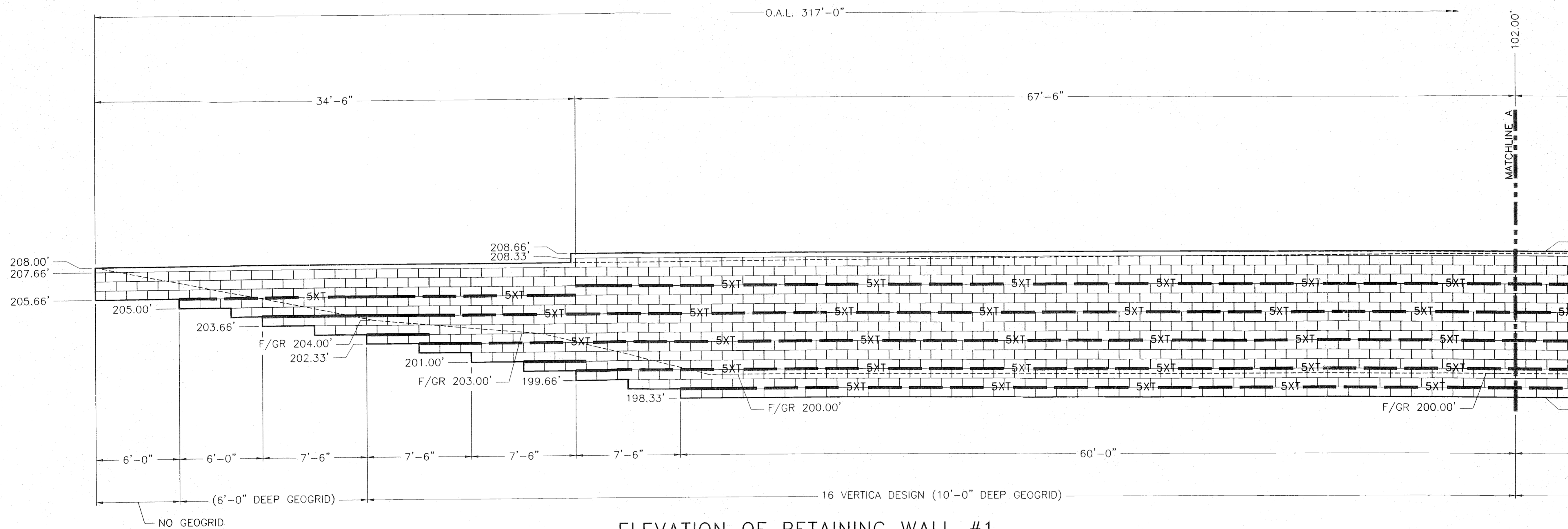

**ELEVATION OF RETAINING WALL #1**  
AT FACE OF WALL

ALL CAPS TO BE 4" CAP UNITS.  
ALL BLOCKS TO BE 8" VERTICA (2' BATTER) WALL UNITS,  
EXCEPT WHERE NOTED.  
ALL GEOGRID TO BE MIRAFI 5XT.  
REFER TO ENGINEERING CROSS-SECTION  
FOR INFORMATION NOT SHOWN.

<b>PATEL CONSULTANTS, INC.</b>			
<small>2826 Safe Harbor Drive, Tampa, Florida 33618 Tel: (813) 932-2875 Service through Excellence</small>			
<small>Babu I. Patel, P.E. Florida Reg. # 20941 Certificate of Authorization # 9288</small>	<small>PROJECT</small>	<b>HANCOCK COMMONS LAKE COUNTY, FLORIDA</b>	
<small>SEAL</small> <i>Babu I. Patel</i> <i>11/21/07</i>	<small>TITLE</small>	<b>ELEVATION OF RETAINING WALL #1 PCI# 7009</b>	
<small>DRAWN</small> JRS 1-30-07	<small>SCALE</small> 1/4" = 1'-0"	<small>REV</small> 0	<small>SHEET</small> PC - 4
<small>APPROVED</small>			

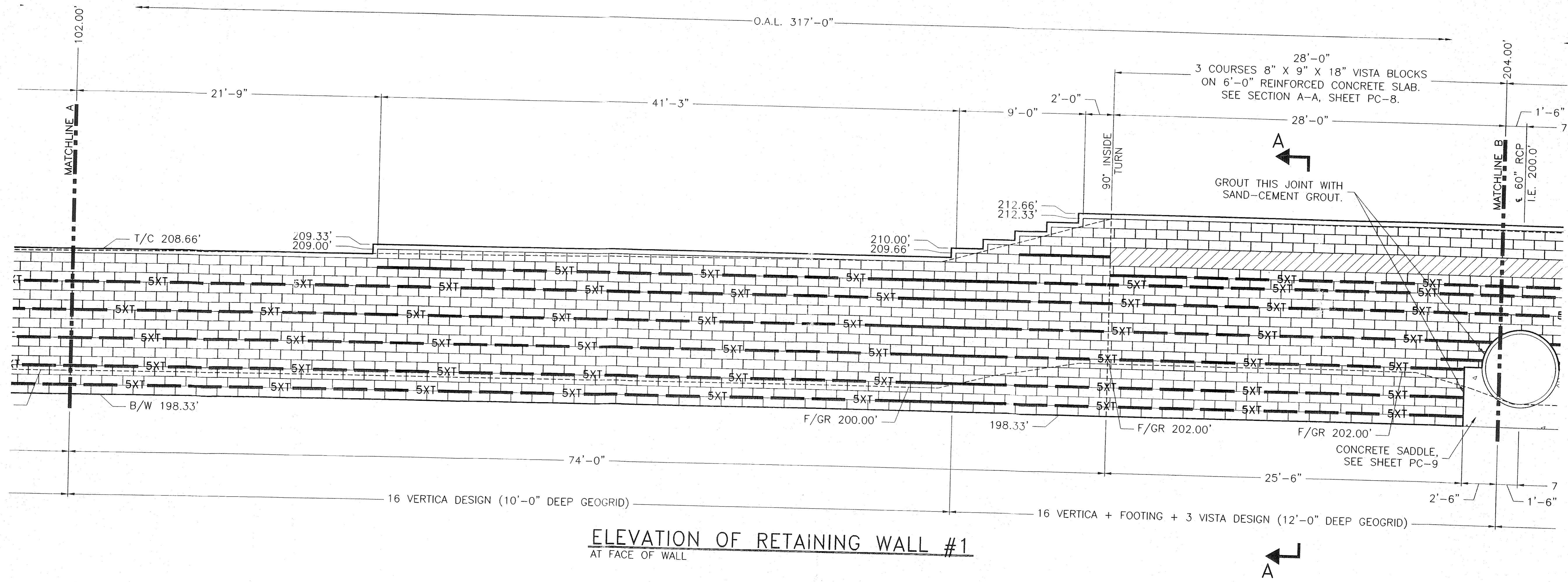

ALL CAPS TO BE 4" CAP UNITS.  
 ALL BLOCKS TO BE 8" VERTICA (2' BATTER) WALL UNITS,  
 EXCEPT WHERE NOTED.  
 ALL GEOGRID TO BE MIRAFI 5XT.  
 REFER TO ENGINEERING CROSS-SECTION  
 FOR INFORMATION NOT SHOWN.

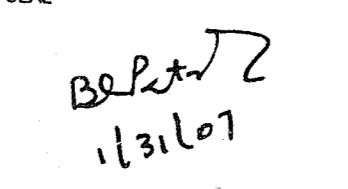
<b>PATEL CONSULTANTS, INC.</b>			
2826 Safe Harbor Drive, Tampa, Florida 33618 Tel: (813) 932-2875 <span style="float: right;">Service through Excellence</span>			
PROJECT Babu I. Patel, P.E. Florida Reg. # 20941 Certificate of Authorization # 9288		TITLE <b>HANCOCK COMMONS</b> <b>LAKE COUNTY, FLORIDA</b>	
DRAWN JRS 1-30-07		SCALE 1/4" = 1'-0"	
APPROVED 		REV SHEET 0 PC - 5	

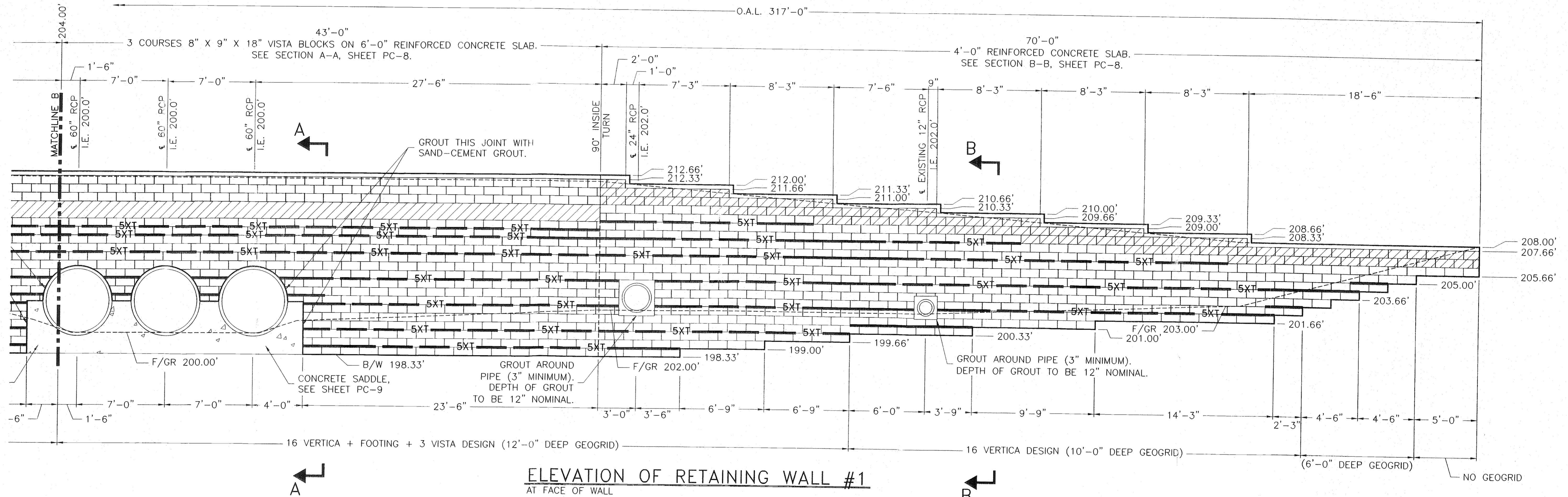

ALL CAPS TO BE 4" CAP UNITS.  
ALL BLOCKS TO BE 8" VERTICA (2' BATTER) WALL UNITS,  
EXCEPT WHERE NOTED.  
ALL GEOGRID TO BE MIRAFI 5XT.  
REFER TO ENGINEERING CROSS-SECTION  
FOR INFORMATION NOT SHOWN.

<b>PATEL CONSULTANTS, INC.</b>			
2826 Safe Harbor Drive, Tampa, Florida 33618 Tel: (813) 932-2875 Service through Excellence			
Babu I. Patel, P.E. Florida Reg. # 20941 Certificate of Authorization # 9288	PROJECT	HANCOCK COMMONS LAKE COUNTY, FLORIDA	
SEAL	TITLE	ELEVATION OF RETAINING WALL #1 PCI# 7009	
DRAWN JRS 1-30-07	SCALE 1/4" = 1'-0"	REV 0	SHEET PC - 6

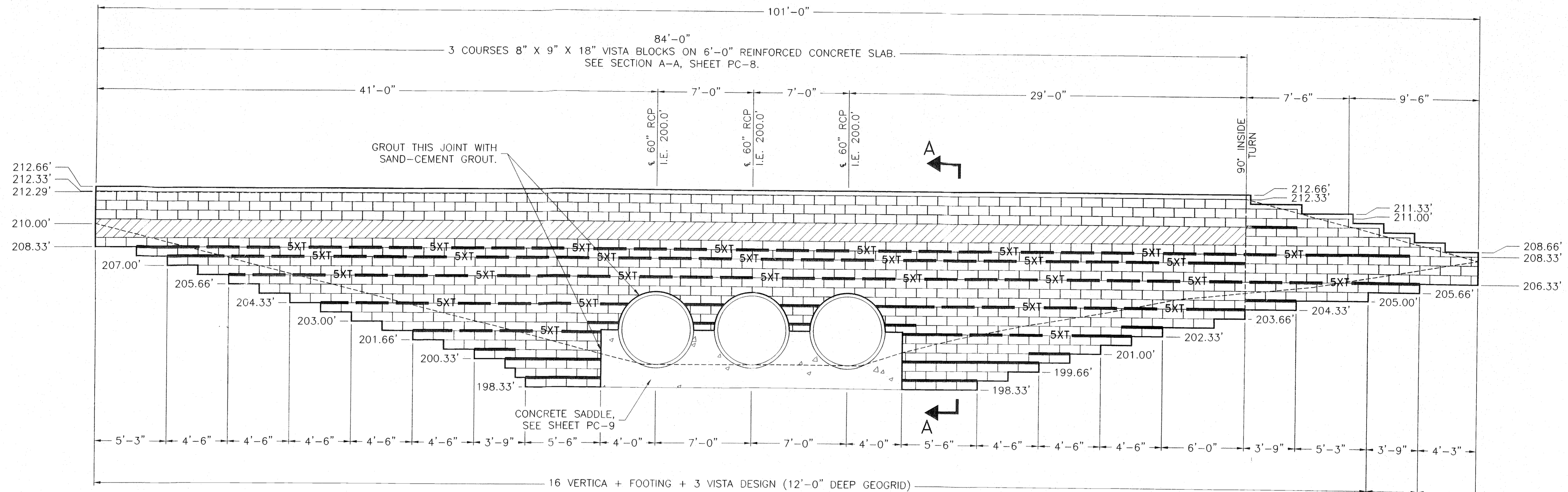

**ELEVATION OF RETAINING WALL #2**  
AT FACE OF WALL

ALL CAPS TO BE 4" CAP UNITS.  
ALL BLOCKS TO BE 8" VERTICA (2' BATTER) WALL UNITS, EXCEPT WHERE NOTED.  
ALL GEOGRID TO BE MIRAFI 5XT.  
REFER TO ENGINEERING CROSS-SECTION FOR INFORMATION NOT SHOWN.

<b>PATEL CONSULTANTS, INC.</b>			
<small>2826 Safe Harbor Drive, Tampa, Florida 33618 Tel: (813) 932-2875 Service through Excellence</small>			
<small>Babu I. Patel, P.E. Florida Reg. # 20941 Certificate of Authorization # 9288</small>	<small>PROJECT</small>	<b>HANCOCK COMMONS LAKE COUNTY, FLORIDA</b>	
<small>SEAL</small> <i>B. Patel</i> 1/3/07	<small>TITLE</small>	<b>ELEVATION OF RETAINING WALL #2 PCI# 7009</b>	
<small>DRAWN</small> JRS 1-30-07	<small>SCALE</small> 1/4" = 1'-0"	<small>REV</small> 0	<small>SHEET</small> PC - 7
<small>APPROVED</small>			

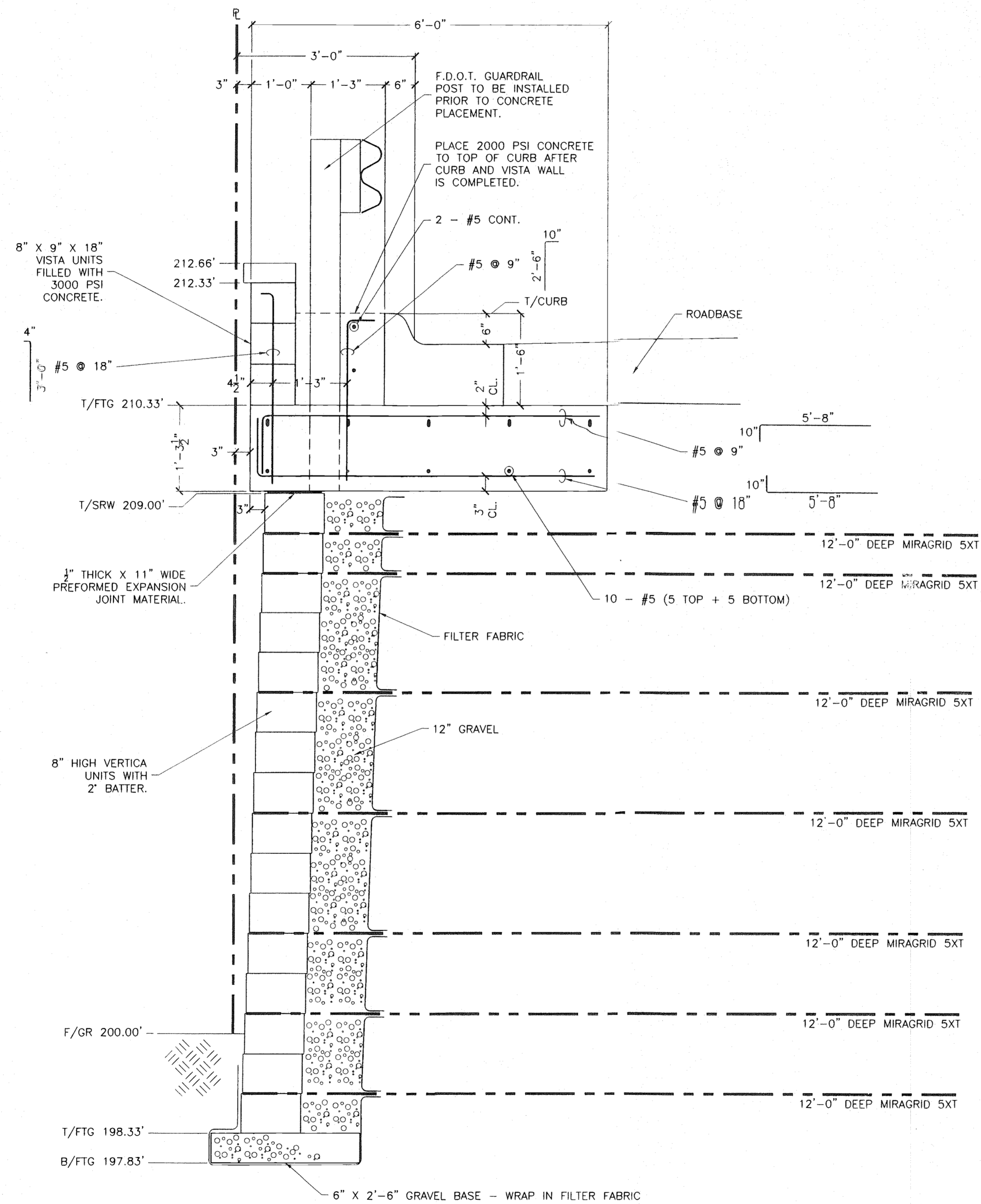

SECTION A-A

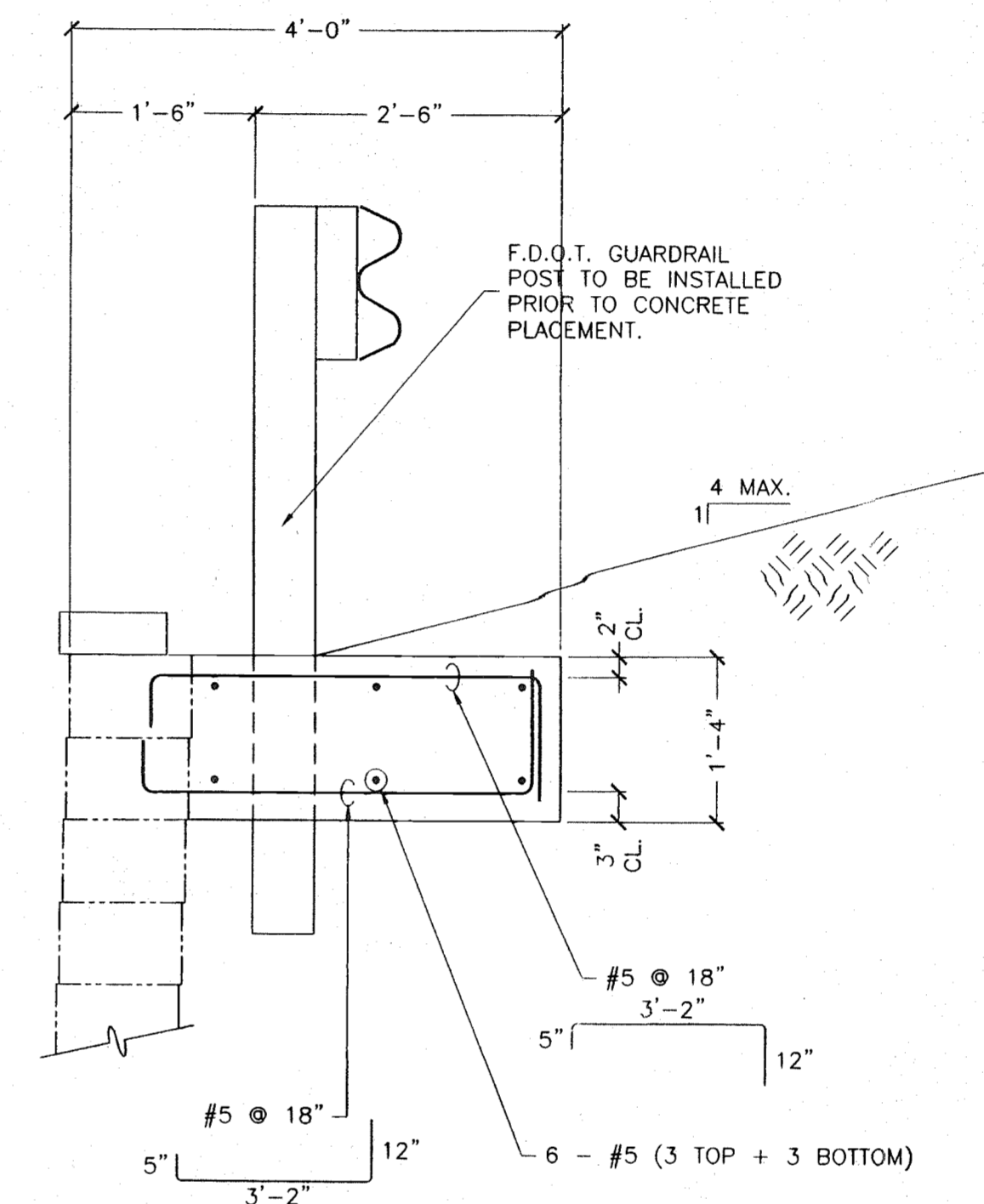

SECTION B-B

<b>PATEL CONSULTANTS, INC.</b>			
2826 Safe Harbor Drive, Tampa, Florida 33618 Tel: (813) 932-2875 Service through Excellence			
Babu I. Patel, P.E. Florida Reg. # 20941 Certificate of Authorization # 9288	PROJECT	HANCOCK COMMONS LAKE COUNTY, FLORIDA	
SEAL	TITLE	CROSS SECTIONS PCI# 7009	
DRAWN JRS 1-30-07	SCALE 3/4" = 1'-0"	REV 0	SHEET PC - 8
APPROVED			



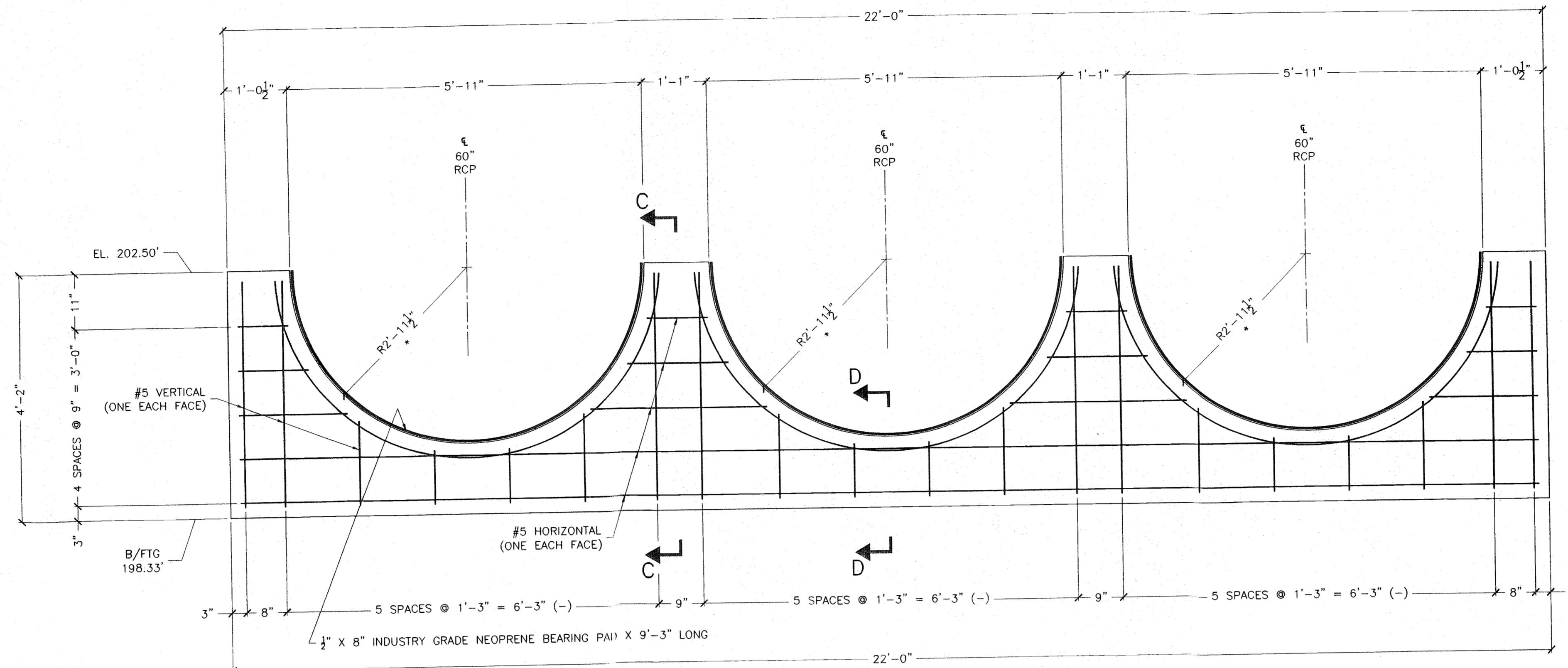

\* CONTRACTOR TO VERIFY PIPE OUTSIDE DIAMETER (70 INCHES) PRIOR TO PLACING THIS CONCRETE.

**PIPE SADDLE DETAIL**

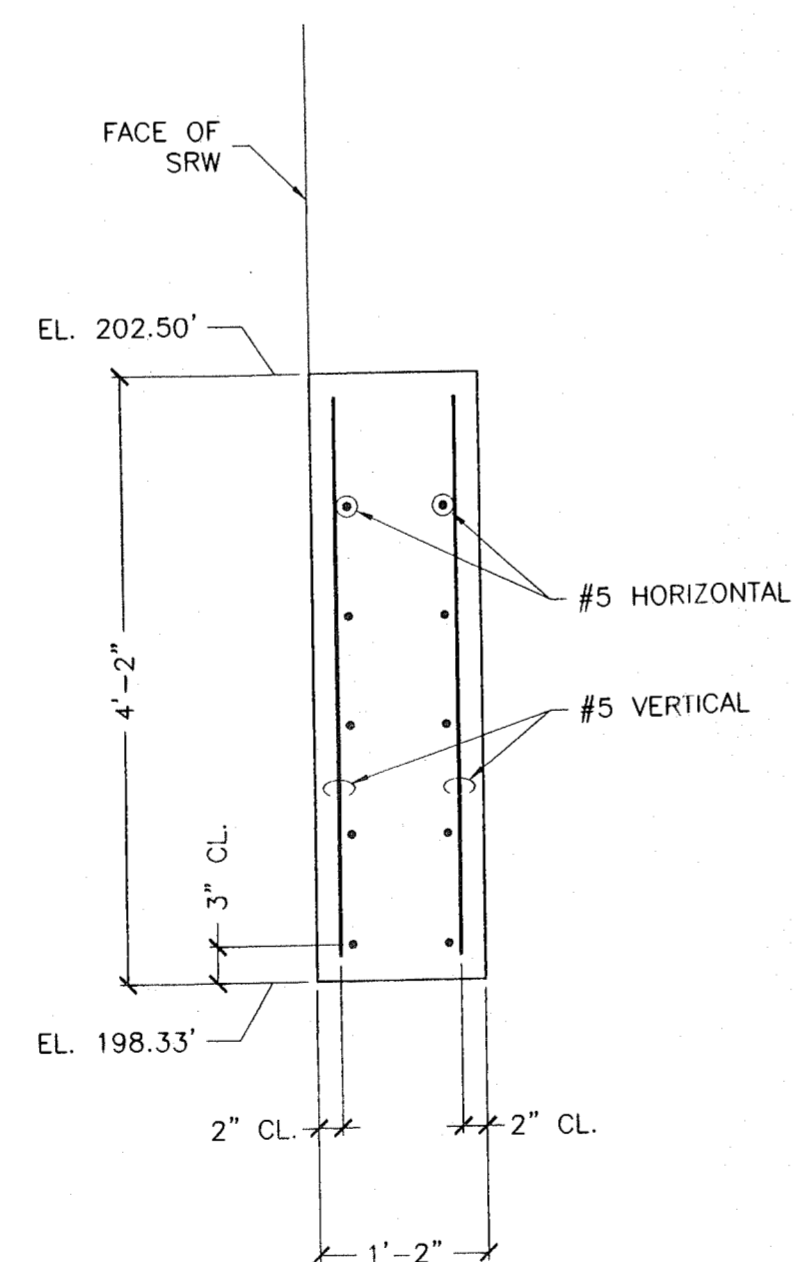

**SECTION C-C**  
(60" RCP SADDLE)

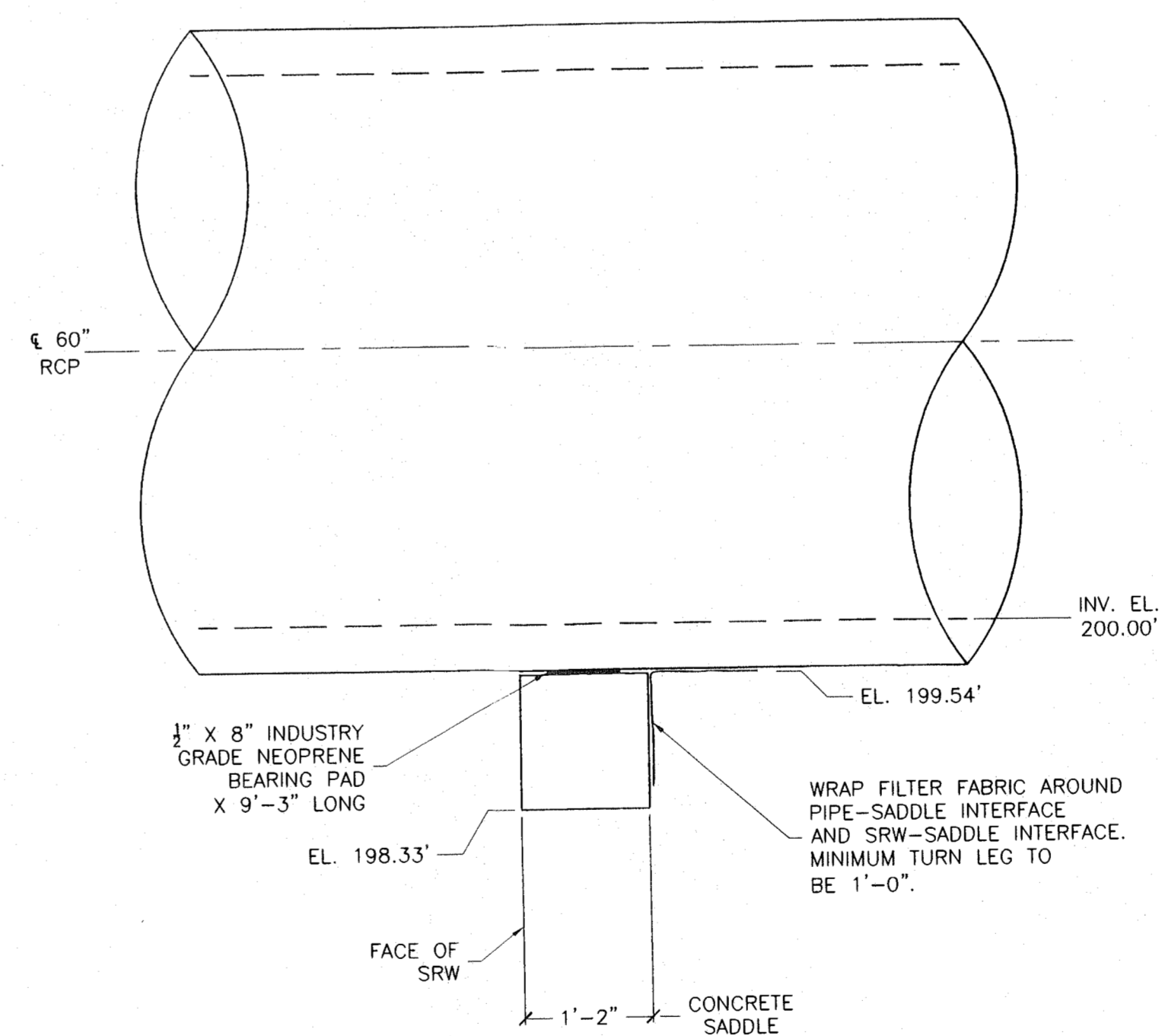

**SECTION D-D**  
CONCRETE SADDLE REINFORCING NOT SHOWN FOR CLARITY

<b>PATEL CONSULTANTS, INC.</b>			
2826 Safe Harbor Drive, Tampa, Florida 33618 Tel: (813) 932-2875 <span style="float: right;">Service through Excellence</span>			
Babu I. Patel, P.E. Florida Reg. # 20941 Certificate of Authorization # 9288		PROJECT <b>HANCOCK COMMONS          LAKE COUNTY, FLORIDA</b>	
TITLE <b>PIPE SADDLE DETAILS          PCI# 7009</b>		SCALE <b>3/4" = 1'-0"</b>	
DRAWN JRS 1-30-07	APPROVED 	REV <b>0</b>	SHEET <b>PC - 9</b>

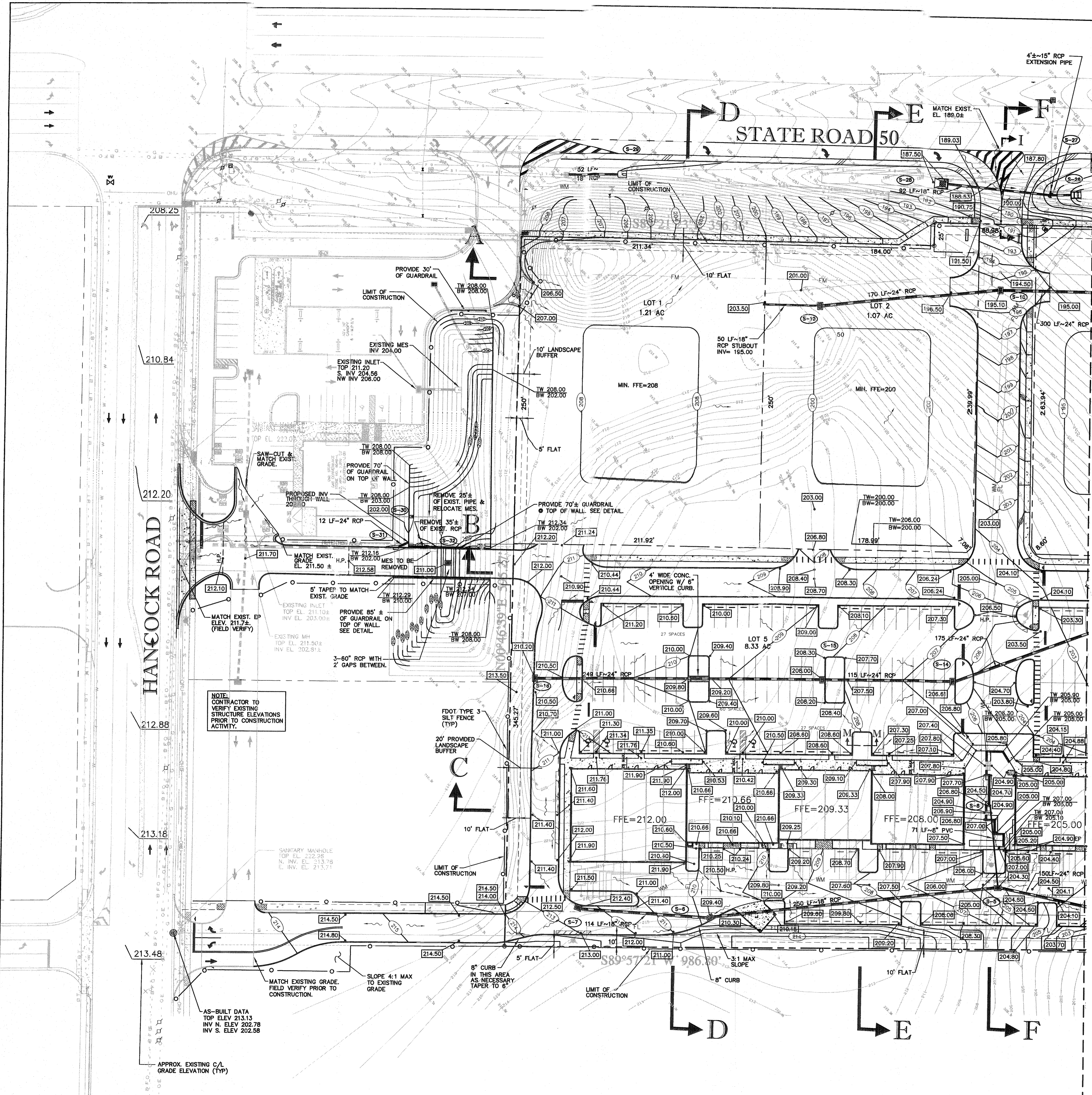

GRAPHIC SCALE

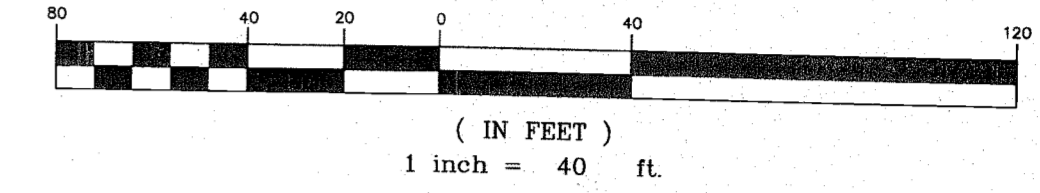

GENERAL NOTES

- CONTRACTOR SHALL VERIFY ALL EXISTING GRADES ON SITE BEFORE BEGINNING WORK. THE OWNER'S REPRESENTATIVE SHALL BE NOTIFIED IMMEDIATELY OF ANY MAJOR DIFFERENCES BETWEEN CONTRACTOR'S DATA AND DRAWINGS.
- THE CONTRACTOR SHALL PROTECT ALL EXISTING STORMWATER COLLECTION SYSTEMS FROM DAMAGE BY SEDIMENT OR OTHER CONSTRUCTION RELATED CAUSES.
- SIZES, LOCATION AND INVERT ELEVATIONS OF EXISTING PIPE TO BE VERIFIED BY THE CONTRACTOR PRIOR TO CONSTRUCTION.
- EROSION CONTROL SHALL BE MAINTAINED WITHIN CONSTRUCTION AREAS BY QUICKLY STABILIZING DISTURBED AREAS TO PREVENT THE RELEASE OF SEDIMENT. THIS SHALL BE ACCOMPLISHED USING SOD, HAY BALES, AND OTHER MEANS ACCEPTABLE TO OWNER, ENGINEER AND REGULATORY AGENCIES.
- ALL STORM DRAINAGE INLETS AND PIPES SHALL BE PROTECTED FROM SILT, SAND AND DEBRIS DURING CONSTRUCTION. ANY ACCUMULATION OF DEBRIS WITHIN THE STORM DRAINAGE PIPE SYSTEM SHALL BE REMOVED.
- SILT FENCE SHALL BE IN-PLACE AS SHOWN PRIOR TO CONSTRUCTION. PLEASE SEE DETAIL SHEETS AND SPECIFICATIONS FOR ADDITIONAL INFORMATION ON EROSION CONTROL.
- EXCESS EXCAVATED UNSUITABLE MATERIAL SHALL BE DISPOSED OF OFF-SITE BY THE CONTRACTOR.
- DEWATERING, IF REQUIRED, DURING CONSTRUCTION SHALL BE IMPLEMENTED IN ACCORDANCE WITH THE TECHNICAL SPECIFICATIONS.
- ALL DISTURBED AREAS TO BE SODDED EXCEPT AS SHOWN ON PLAN. ALL SOD IN R/W TO BE ARGENTINE BAHIA.
- GRADING SHOWN ON THESE PLANS IS PROMOUNT THE ENTIRE SITE TO PROVIDE POSITIVE DRAINAGE IN ALL AREAS THROUGHOUT THE SITE. SMOOTH TRANSITIONS SHALL BE PROVIDED BETWEEN CONTOURS OR SPOT ELEVATIONS. GRADING EQUIPMENT TO DETERMINE THAT THE GRADING INTENT HAS BEEN ACHIEVED.
- CONTOURS ON PARKING AREAS ARE SHOWN TO DEMONSTRATE INTENT ONLY. THE PARKING FACILITIES TO BE CONSTRUCTED USING SPOT ELEVATIONS SHOWN.
- CONTRACTOR TO COORDINATE WITH ARCH. PLANS FOR ROOF DRAIN CONNECTION LOCATION.
- CLEAN DIRT FROM ROADWAYS DAILY.
- EMPLOY SAFETY AND ROADWAY ENTRY AND EXIT PLANS ON A DAILY/WEEKLY BASIS.
- COORDINATE ALL UTILITY CROSSINGS AND ADDRESS CONFLICTS IN ADVANCE OF BEGINNING WORK IN A GIVEN AREA(S).

STORM SEWER SCHEDULE

STRUCTURE TO HAVE TRAFFIC BEARING GRADE			
S-1	TYPE "C" INLET TOP ELEV. 171.00 SLOT ELEV. N & S 169.00 INV. 167.50 BOTTOM ELEV. 165.50	S-23	TYPE "B" INLET DITCH BOTTOM TOP ELEV. 163.00 INV. 158.50
S-2	TYPE "C" INLET TOP ELEV. 199.00 INV. 191.00	S-24	MES INV. 159.00
S-3	TYPE "C" INLET TOP ELEV. 198.20 INV. 192.00	S-25	EXIST. MES TO BE REMOVED. REPLACE WITH MANHOLE TOP ELEV. MATCH PVMT. 163.0± INV. 159.28± (MATCH EXIST. PIPE)
S-4	TYPE "C" INLET TOP ELEV. 200.00 INV. 193.60	S-26	5'x8' CONCRETE FLUME W/ DISSIPATOR TOP ELEV. 204.30 INV. 201.00
S-5	TYPE "C" INLET TOP ELEV. 204.30 INV. 197.80	S-27	MANHOLE TOP ELEV. 185.50 INV. 182.12± (MATCH EXIST. PIPE)
S-6	TYPE "C" INLET TOP ELEV. 209.90 INV. 200.78	S-28	TYPE "B" DITCH BOTTOM INLET TOP ELEV. 167.50 INV. 163.00
S-7	TYPE "C" INLET TOP ELEV. 212.40 INV. 204.90	S-29	MES INV. 200.00
S-8	YARD DRAIN TOP ELEV. 204.50 INV. 198.50	S-30	PROPOSED MES INV. 202.00
S-9	TYPE "C" INLET TOP ELEV. 171.00 SLOT ELEV. N & S 169.00 INV. 167.50 BOTTOM ELEV. 165.50	S-31	PROPOSED CURB INLET TYPE J BOTTOM W/ TYPE 5 TOP TOP EL. 212.24 INV. MATCH EXIST. PIPE INV. 202.16±
S-10	TYPE "C" INLET TOP ELEV. 185.60 INV. 171.00	S-32	TYPE "D" INLET TOP 211.00 INV. 200.00
S-11	TYPE "C" INLET TOP ELEV. 195.70 INV. 180.00	S-22	5'x8' CONCRETE FLUME W/ DISSIPATOR TOP ELEV. 204.30 INV. 201.00 (MATCH EXISTING)
S-12	TYPE "C" INLET TOP ELEV. 199.00 INV. 189.50		
S-13	TYPE "C" INLET TOP ELEV. 200.50 INV. 191.50		
S-14	TYPE "C" INLET TOP ELEV. 198.20 INV. 192.00		
S-15	TYPE "C" INLET TOP ELEV. 208.00 INV. 199.00		
S-16	TYPE "C" INLET TOP ELEV. 210.20 INV. 201.00		
S-17	TYPE "C" INLET TOP ELEV. 187.75 INV. 182.00		
S-18	TYPE "C" INLET TOP ELEV. 212.40 INV. 188.60		
S-19	TYPE "C" INLET TOP ELEV. 201.00 INV. 194.50		
S-20	TYPE "C" INLET TOP ELEV. 179.76 INV. 172.00		
S-21	OUTFALL STRUCTURE TYPE "C" INLET TOP ELEV. 178.50 INV. 172.55		

LEGEND

- — SILT FENCE & LIMIT OF CONSTRUCTION
- — PROPOSED SPOT ELEVATION AT EP AND HARDSCAPES UNLESS STATED OTHERWISE
- — STORM STRUCTURE IDENTIFICATION
- — EXISTING SPOT ELEV.
- — PROPOSED CONTOUR ELEVATION
- — STORMWATER SURFACE FLOW
- C.O. — CLEAN OUT
- RDC — ROOF DRAIN CONNECTION

FOR REVIEW ONLY

CERT. OF AUTHORIZATION # 7350

SCOTT M. GENTRY, P.E.  
FLORIDA REGISTRATION 44677  
NOT VALID FOR CONSTRUCTION  
UNLESS SIGNED IN THIS BLOCK

**KCG**  
KELLY, COLLINS & GENTRY, INC.  
1700 NORTH ORANGE AVENUE, SUITE 400  
ORLANDO, FLORIDA 32804  
(407) 686-7668 FAX (407) 686-1498

NO.	DATE	REVISION
6		
5		
4		
3		
2		
1		

PREPARED FOR:  
**TRYCON ASSOCIATES**

**HANCOCK COMMONS  
CLERMONT, FLORIDA**

**PAVING, GRADING &  
DRAINAGE PLAN**

DRAWN: JR  
DESIGN: CAG  
CHECKED: SMG  
JOB NO.: 432-000  
DATE: 11/06/08  
SHEET  
C-4

MATCH LINE

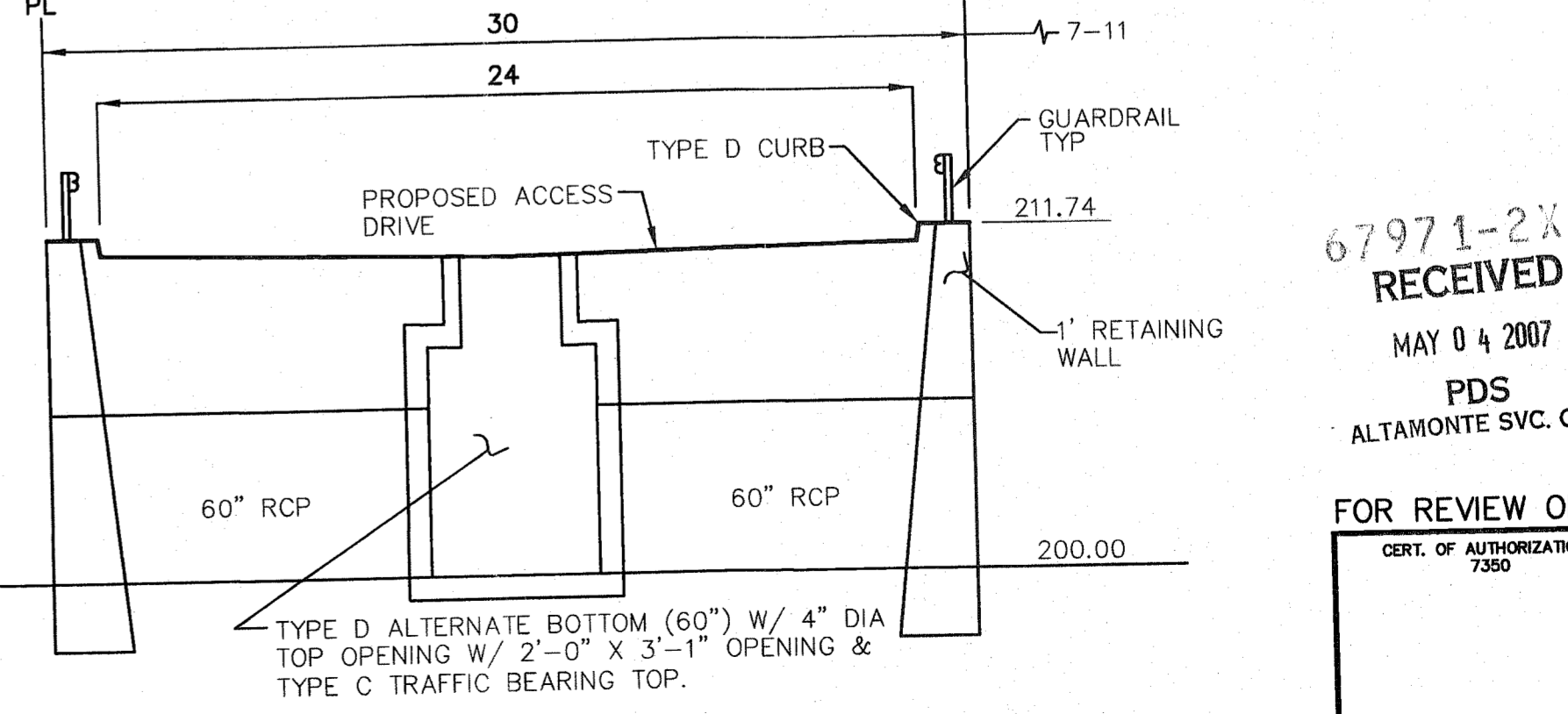
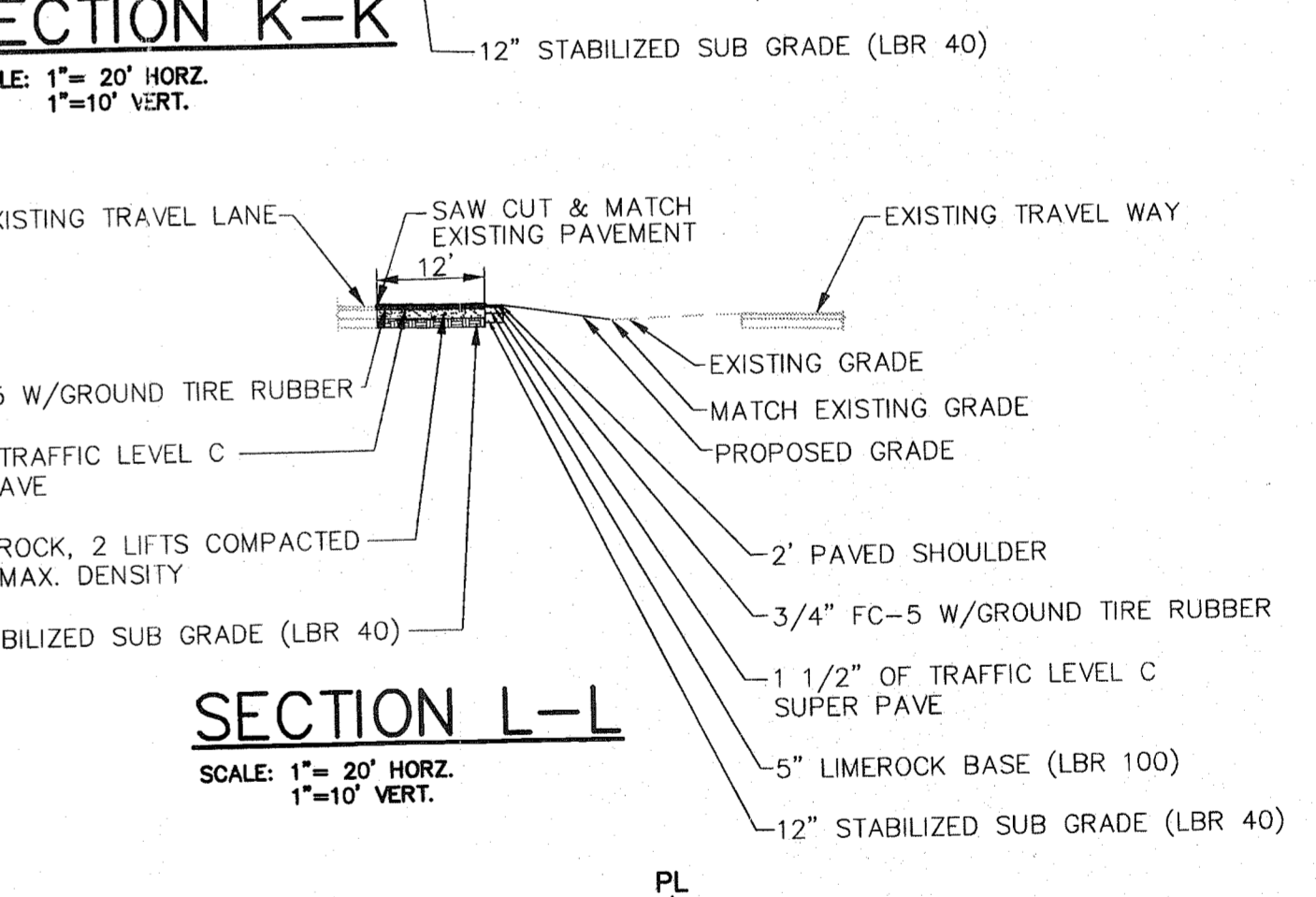
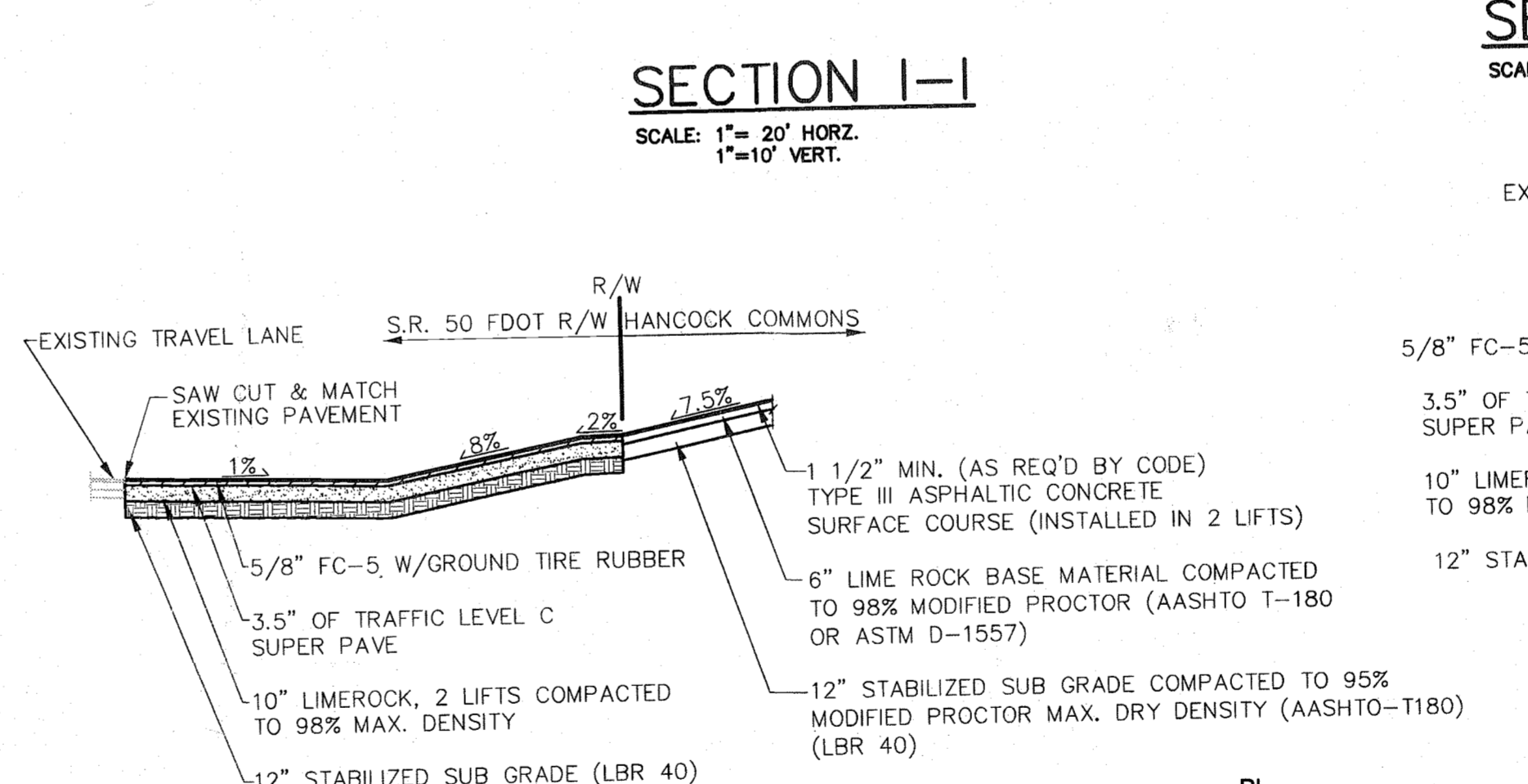
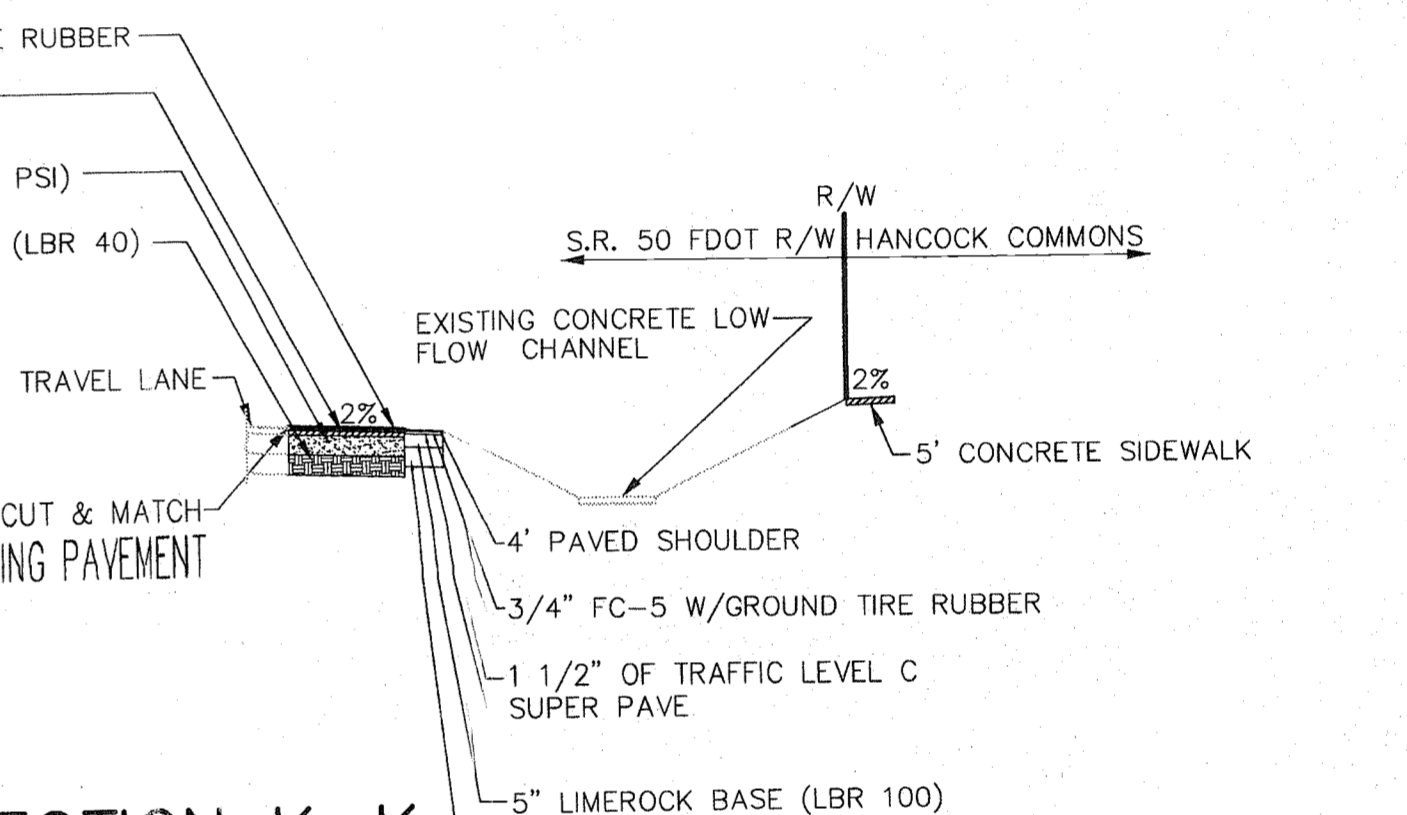
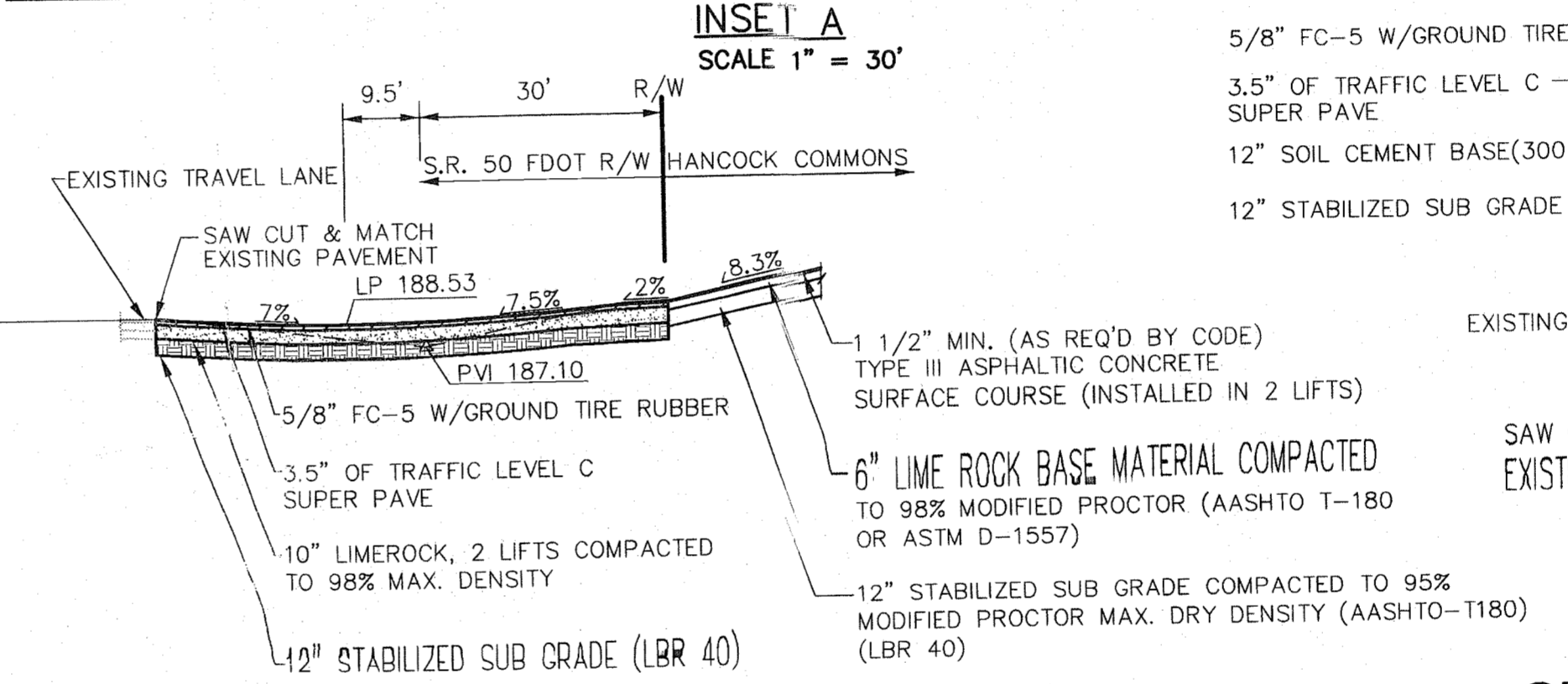
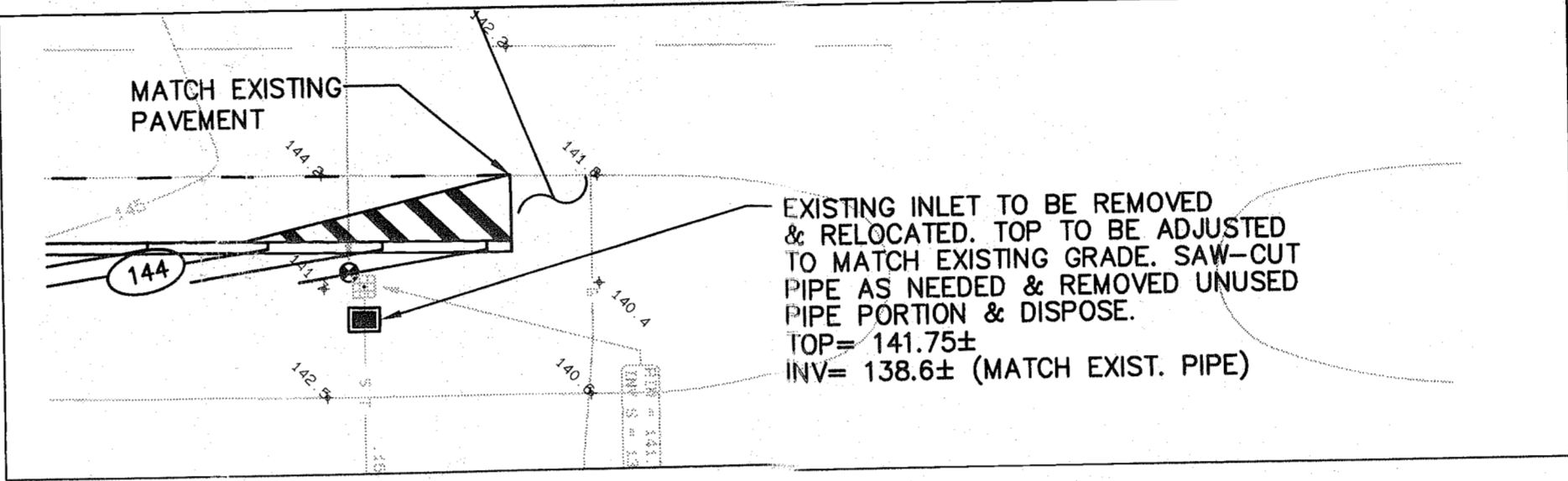
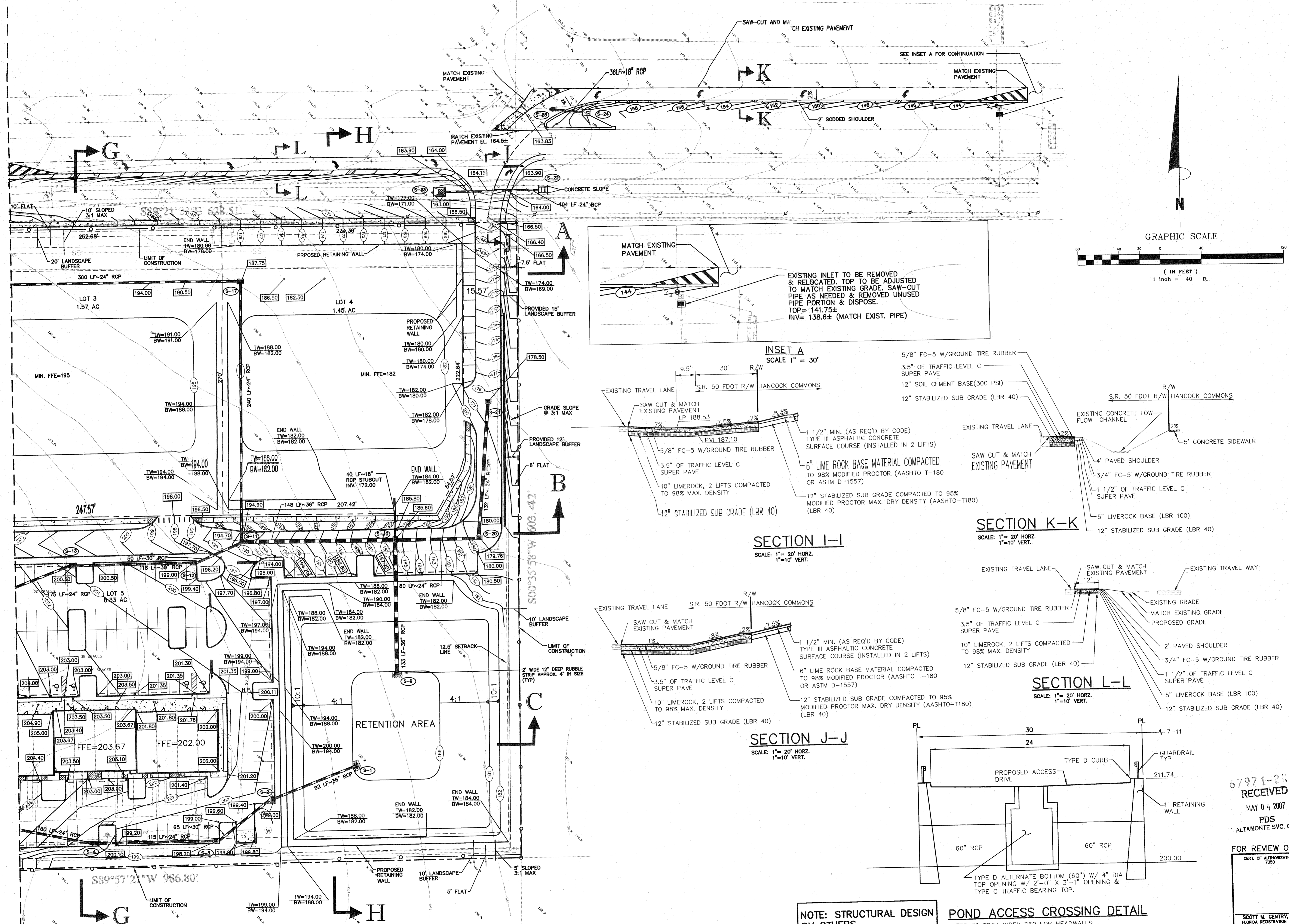

**NOTE: STRUCTURAL DESIGN BY OTHERS.**

**POND ACCESS CROSSING DETAIL**  
REFER TO FOOT INDEX 250 FOR HEADWALLS  
REFER TO FOOT INDEX 232 FOR STRUCTURE

67971-2X  
**RECEIVED**  
MAY 04 2007  
PDS  
ALAMONTE SVC. CTR.

FOR REVIEW ONLY  
CERT. OF AUTHORIZATION # 750

DRAWN: JRB  
DESIGN: CAG  
CHECKED: SMG  
JOB NO.: 432.000  
DATE: 11/08/06

SHEET  
C-5

**KCG**  
KELLY, COLLINS & GENTRY, INC.  
1700 NORTH ORANGE AVENUE, SUITE 400  
ORLANDO, FLORIDA 32804  
(407) 898-7868 FAX (407) 898-1488

PREPARED FOR:  
**TRYCON ASSOCIATES**

**HANCOCK COMMONS CLERMONT, FLORIDA**

**PAVING, GRADING & DRAINAGE PLAN**

REVISION  
DATE

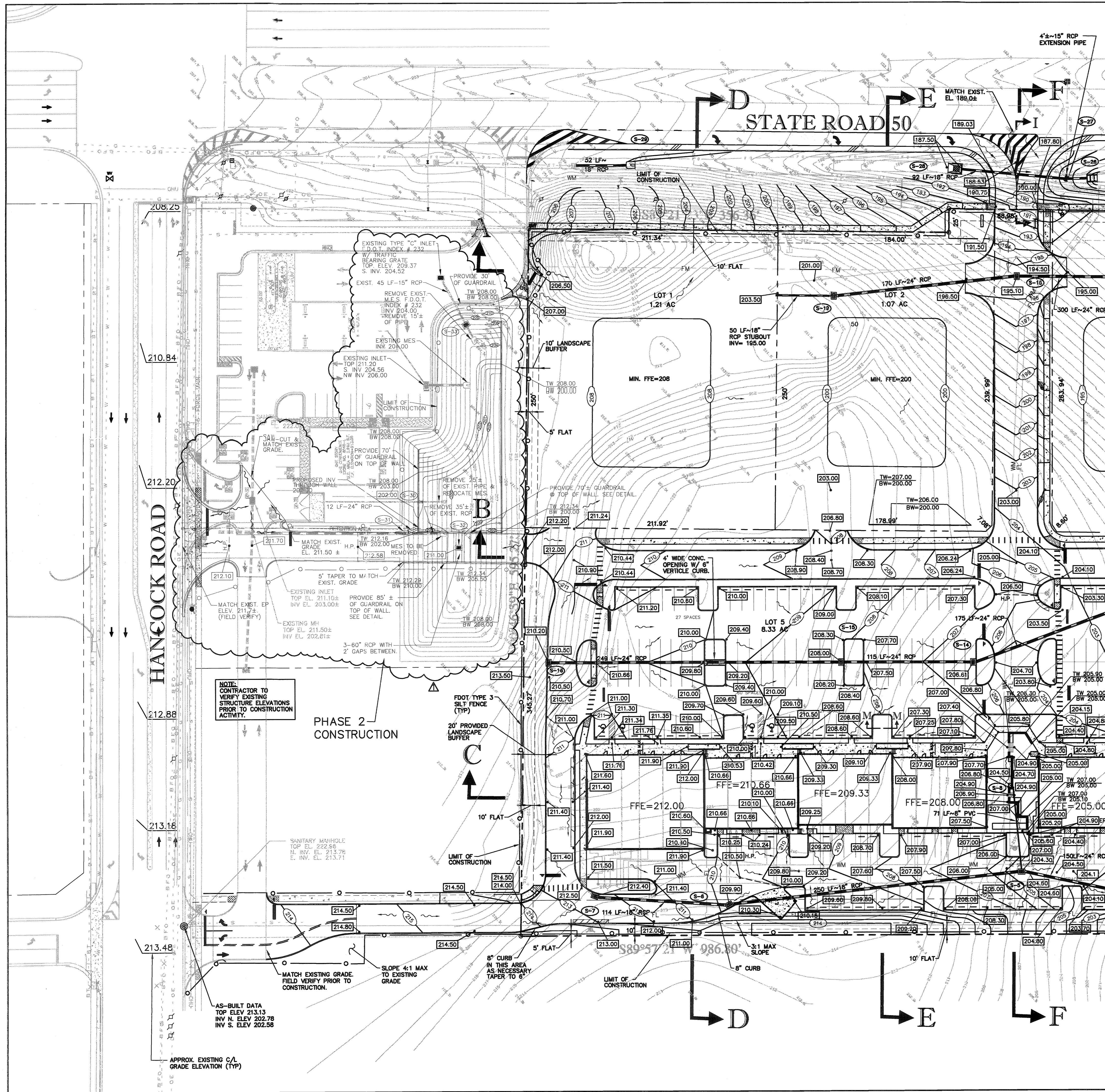

**FINAL PERMITTED PLANS**

DATE \_\_\_\_\_  
INITIAL \_\_\_\_\_

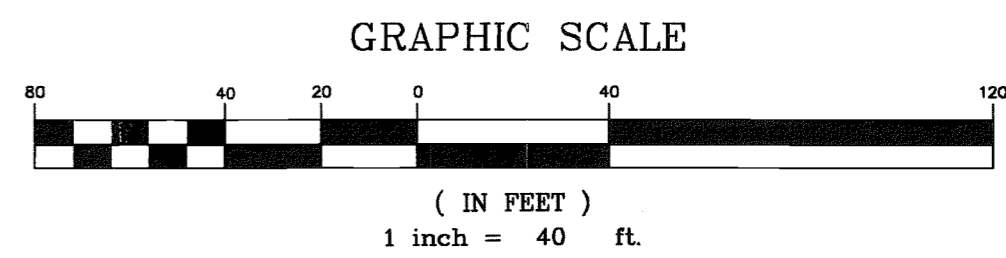

**GENERAL NOTES**

- CONTRACTOR SHALL VERIFY ALL EXISTING GRADES ON SITE BEFORE BEGINNING WORK. THE OWNER'S REPRESENTATIVE SHALL BE NOTIFIED IMMEDIATELY OF ANY MAJOR DIFFERENCES BETWEEN CONTRACTOR'S DATA AND DRAWINGS.
- THE CONTRACTOR SHALL PROTECT ALL EXISTING STORMWATER COLLECTION SYSTEMS FROM DAMAGE BY SEDIMENT OR OTHER CONSTRUCTION RELATED CAUSES.
- SIZES, LOCATION AND INVERT ELEVATIONS OF EXISTING PIPE TO BE VERIFIED BY THE CONTRACTOR PRIOR TO CONSTRUCTION.
- EROSION CONTROL SHALL BE MAINTAINED WITHIN CONSTRUCTION AREAS BY QUICKLY STABILIZING DISTURBED AREAS TO PREVENT THE RELEASE OF SEDIMENT. THIS SHALL BE ACCOMPLISHED USING SOD, HAY BALES, AND OTHER MEANS ACCEPTABLE TO OWNER, ENGINEER AND REGULATORY AGENCIES.
- ALL STORM DRAINAGE INLETS AND PIPES SHALL BE PROTECTED FROM SILT, SAND AND DEBRIS DURING CONSTRUCTION. ANY ACCUMULATION OF DEBRIS WITHIN THE STORM DRAINAGE PIPE SYSTEM SHALL BE REMOVED.
- SILT FENCE SHALL BE IN-PLACE AS SHOWN PRIOR TO CONSTRUCTION. PLEASE SEE DETAIL SHEETS AND SPECIFICATIONS FOR ADDITIONAL INFORMATION ON EROSION CONTROL.
- EXCESS EXCAVATED UNSUITABLE MATERIAL SHALL BE DISPOSED OF OFF-SITE BY THE CONTRACTOR.
- DEWATERING, IF REQUIRED, DURING CONSTRUCTION SHALL BE IMPLEMENTED IN ACCORDANCE WITH THE TECHNICAL SPECIFICATIONS.
- ALL DISTURBED AREAS TO BE SODDED EXCEPT AS SHOWN ON PLAN. ALL SOD IN R/W TO BE ARGENTINE BAHIA.
- GRADING SHOWN ON THESE PLANS IS PROVIDED TO THE CONTRACTOR TO EXPRESS THE GENERAL GRADING INTENT OF THE PROJECT. THE CONTRACTOR SHALL BE EXPECTED TO GRADE THE ENTIRE SITE TO PROVIDE POSITIVE DRAINAGE IN ALL AREAS THROUGHOUT THE SITE. SMOOTH TRANSITIONS SHALL BE PROVIDED BETWEEN CONTOURS OR SPOT ELEVATIONS AS SHOWN ON THE PLANS. ALL SLOPES SHALL BE STABILIZED IMMEDIATELY AFTER FINAL GRADING HAS BEEN COMPLETED. CONTRACTOR SHALL NOTIFY OWNER AND ENGINEER PRIOR TO DEMOBILIZATION OF GRADING EQUIPMENT TO DETERMINE THAT THE GRADING INTENT HAS BEEN ACHIEVED.
- CONTOURS FOR PARKING AREAS ARE SHOWN TO DEMONSTRATE INTENT ONLY. THE PARKING FACILITIES TO BE CONSTRUCTED USING SPOT ELEVATIONS SHOWN.
- CONTRACTOR TO COORDINATE WITH ARCH. PLANS FOR ROOF DRAIN CONNECTION LOCATION.
- CLEAN DIRT FROM ROADWAYS DAILY.
- EMPLOY SAFETY AND ROADWAY ENTRY AND EXIT PLANS ON A DAILY/WEEKLY BASIS.
- COORDINATE ALL UTILITY CROSSINGS AND ADDRESS CONFLICTS IN ADVANCE OF BEGINNING WORK IN A GIVEN AREA(S).

**STORM SEWER SCHEDULE**

STRUCTURE TO HAVE TRAFFIC BEARING GRADE			
S-1	TYPE "C" INLET TOP ELEV. 171.00 SLOT ELEV. N & S 169.00 INV. 167.50 BOTTOM ELEV. 165.50	S-23	TYPE "B" INLET DITCH BOTTOM TOP ELEV. 163.00 INV. 158.50
S-2	TYPE "C" INLET TOP ELEV. 199.00 INV. 191.00	S-24	MES INV. 159.00
S-3	TYPE "C" INLET TOP ELEV. 198.20 INV. 192.00	S-25	EXIST. MES TO BE REMOVED. REPLACE WITH MANHOLE TOP ELEV. MATCH PVMT. 163.0± INV. 159.28± (MATCH EXIST. PIPE)
S-4	TYPE "C" INLET TOP ELEV. 200.00 INV. 193.00	S-26	5'X8' CONCRETE FLUME W/ DISSIPATOR TOP ELEV. 204.30 INV. 201.00
S-5	TYPE "C" INLET TOP ELEV. 204.30 INV. 197.80	S-27	MANHOLE TOP ELEV. 185.50 INV. 182.12± (MATCH EXIST. PIPE)
S-6	TYPE "C" INLET TOP ELEV. 209.90 INV. 200.78	S-28	TYPE "B" DITCH BOTTOM INLET TOP ELEV. 187.50 INV. 183.00
S-7	TYPE "C" INLET TOP ELEV. 212.40 INV. 204.90	S-29	MES INV. 200.00
S-8	YARD DRAIN TOP ELEV. 204.50 INV. 198.50	S-30	PROPOSED MES INV. 202.00
S-9	TYPE "C" INLET TOP ELEV. 171.00 SLOT ELEV. N & S 169.00 INV. 167.50 BOTTOM ELEV. 165.50	S-31	PROPOSED CURB INLET TYPE J BOTTOM W/ TYPE S TOP TOP EL. 212.24± INV. MATCH EXIST. PIPE INV. 202.16±
S-10	TYPE "C" INLET TOP ELEV. 185.60 INV. 171.00	S-32	TYPE "D" INLET TOP 211.00 INV. 201.00
S-11	TYPE "C" INLET TOP ELEV. 195.70 INV. 180.00	S-33	PROPOSED TYPE "E" INLET F.D.O.T. INDEX # 232 TOP EL. 209.95 INV. ELEV. 204.37± (MATCH EXIST. PIPE)
S-12	TYPE "C" INLET TOP ELEV. 199.00 INV. 189.50		
S-13	TYPE "C" INLET TOP ELEV. 200.50 INV. 191.50		
S-14	TYPE "C" INLET TOP ELEV. 206.61 INV. 197.50		
S-15	TYPE "C" INLET TOP ELEV. 208.00 INV. 199.00		
S-16	TYPE "C" INLET TOP ELEV. 210.20 INV. 201.00		
S-17	TYPE "C" INLET TOP ELEV. 187.75 INV. 182.00		
S-18	TYPE "C" INLET TOP ELEV. 195.10 INV. 188.60		
S-19	TYPE "C" INLET TOP ELEV. 201.00 INV. 194.50		
S-20	TYPE "C" INLET TOP ELEV. 179.76 INV. 172.00		
S-21	OUTFALL STRUCTURE TYPE "C" INLET TOP ELEV. 178.50 INV. 172.55		
S-22	5'X8' CONCRETE FLUME W/ DISSIPATOR (MATCH EXISTING)		

**LEGEND**

- — SILT FENCE & LIMIT OF CONSTRUCTION
- — PROPOSED SPOT ELEVATION AT EP AND HARDSCAPES UNLESS STATED OTHERWISE
- — STORM STRUCTURE IDENTIFICATION
- — EXISTING SPOT ELEV.
- — PROPOSED CONTOUR ELEVATION
- — STORMWATER SURFACE FLOW
- C.O. — CLEAN OUT
- RDC — ROOF DRAIN CONNECTION

67971-2X  
**RECEIVED**  
MAY 04 2007  
PDS  
ALTA MONTE SVC. CTR.

FOR REVIEW ONLY  
CERT. OF AUTHORIZATION # 1390  
SCOTT M. GENTRY, P.E.  
FLORIDA REGISTRATION # 44677  
NOT VALID FOR CONSTRUCTION  
UNLESS SIGNED IN THIS BLOCK

**NOTE:**  
CONTRACTOR TO VERIFY EXISTING STRUCTURE ELEVATIONS PRIOR TO CONSTRUCTION ACTIVITY.

AS-BUILT DATA  
TOP ELEV. 213.13  
INV. N. ELEV. 202.78  
INV. S. ELEV. 202.58

APPROX. EXISTING C/L GRADE ELEVATION (TYP)

**KELLY, COLLINS & GENTRY, INC.**  
1700 NORTH GRANGER AVENUE, SUITE 400  
ORLANDO, FLORIDA 32804  
(407) 898-7868 FAX (407) 898-1488

**KCG**

PREPARED FOR: **TRYCON ASSOCIATES**

**HANCOCK COMMONS CLERMONT, FLORIDA**

**PAVING, GRADING & DRAINAGE PLAN**

DATE: 4/17/07  
REVISION: SHOW PHASE 2 CONSTRUCTION

DRAWN: JRB  
DESIGN: CAG  
CHECKED: SMG  
JOB NO.: 432.000  
DATE: 11/06/06

SHEET C-4

# STATE ROAD 50

# HANCOCK ROAD

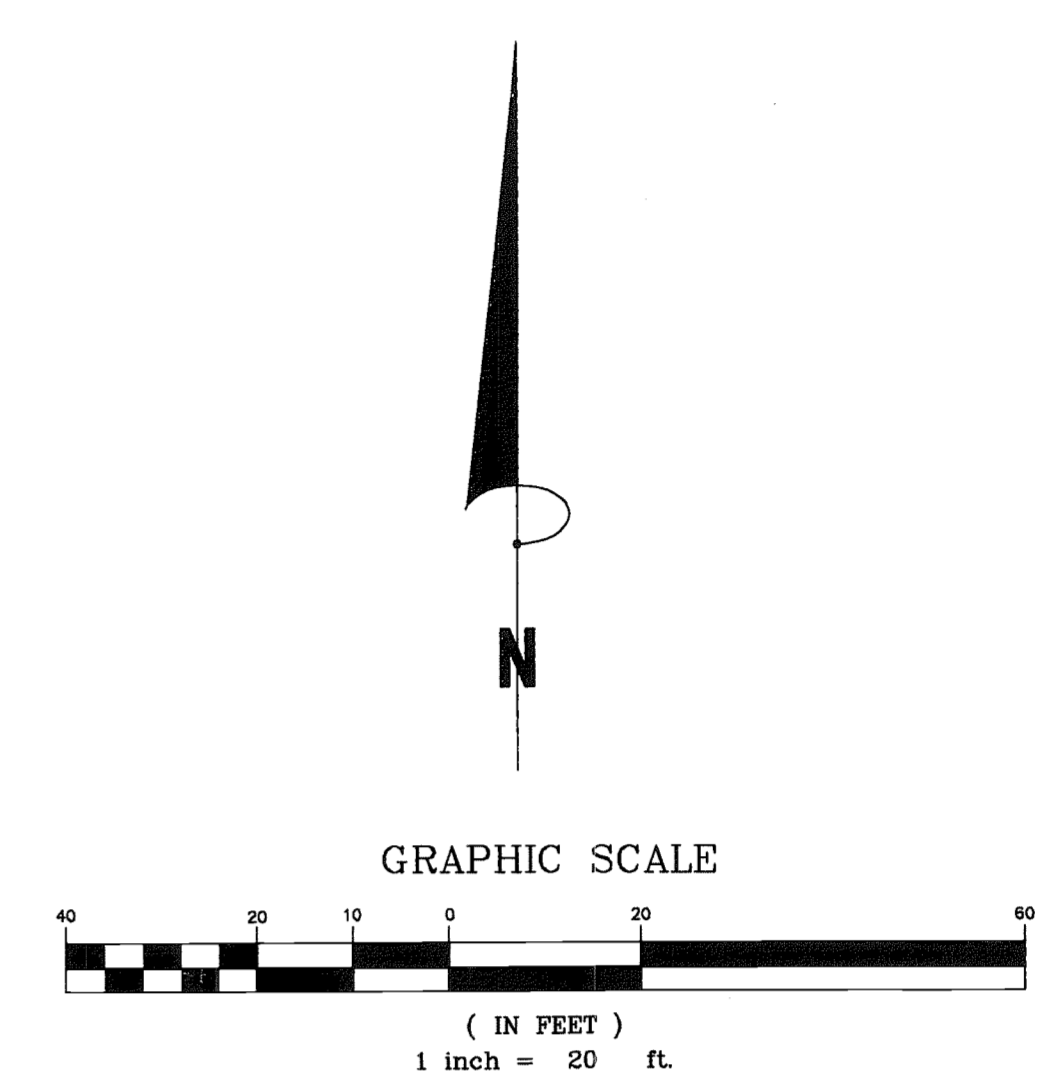
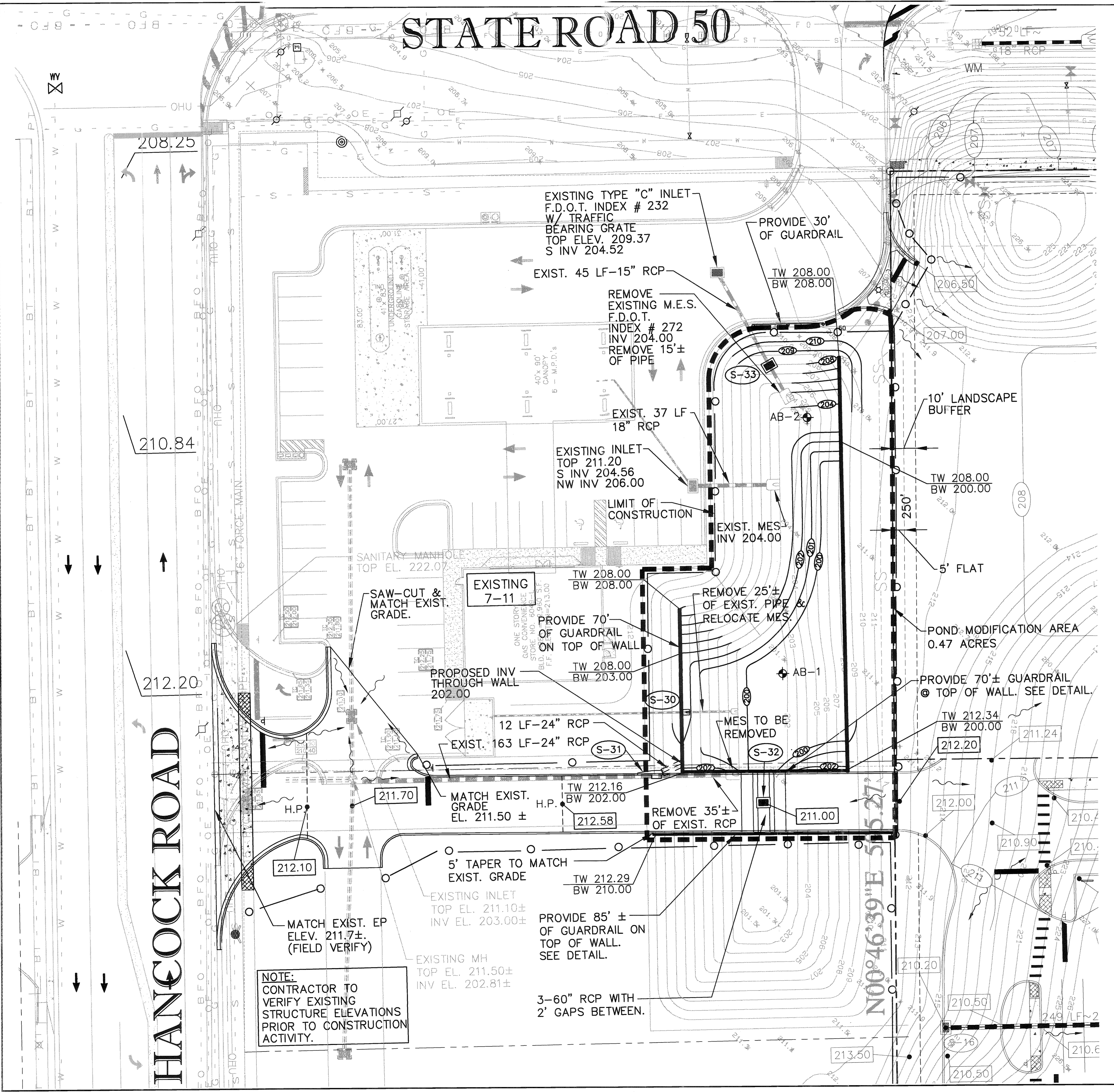

### LEGEND

- — SILT FENCE & LIMIT OF CONSTRUCTION
- — PROPOSED SPOT ELEVATION AT EP AND HARDSCAPES UNLESS STATED OTHERWISE
- S-1 — STORM STRUCTURE IDENTIFICATION
- 92.50 — EXISTING SPOT ELEV.
- 165 — PROPOSED CONTOUR ELEVATION
- — STORMWATER SURFACE FLOW
- C.O. — CLEAN OUT
- RDC — ROOF DRAIN CONNECTION
- ⊕ — BORING LOCATION

### STORM SEWER SCHEDULE

- STRUCTURE TO HAVE TRAFFIC BEARING GRATE
- (S-30) PROPOSED MES F.D.O.T. INDEX # 272 INV. ELEV. = 202.00
  - (S-31) PROPOSED CURB INLET TYPE J BOTTOM W/ TYPE 5 TOP TOP ELEV. = 212.24 INV. ELEV. MATCH EXIST. PIPE INV. ELEV. = 202.16±
  - (S-32) PROPOSED TYPE "D" INLET F.D.O.T. INDEX # 232 TOP ELEV. = 211.00 INV. ELEV. = 200.00
  - (S-33) PROPOSED TYPE "C" INLET F.D.O.T. INDEX # 232 TOP ELEV. = 209.95 INV. ELEV. = 204.37± (MATCH EXIST. PIPE)

FOR REVIEW ONLY  
 CERT. OF AUTHORIZATION # 7550  
 SCOTT M. GENTRY, P.E.  
 FLORIDA REGISTRATION 44677  
 NOT VALID FOR CONSTRUCTION UNLESS SIGNED IN THIS BLOCK

**KELLY,  
COLLINS &  
GENTRY, INC.**

7901 NORTH AVENUE AVENUE, SUITE 400  
CORAL SPRING, FLORIDA 32935  
(407) 888-7668 FAX (407) 888-1488

DATE

1 4/17/07

REVISION

SHOW PHASE 2 CONSTRUCTION

PREPARED FOR:

**TRYCON  
ASSOCIATES**

PROJECT:

**HANCOCK COMMONS  
CLERMONT, FLORIDA**

DESIGNED BY:

**DRAINAGE PLAN**

SHEET

**C-4B**

MATCH LINE

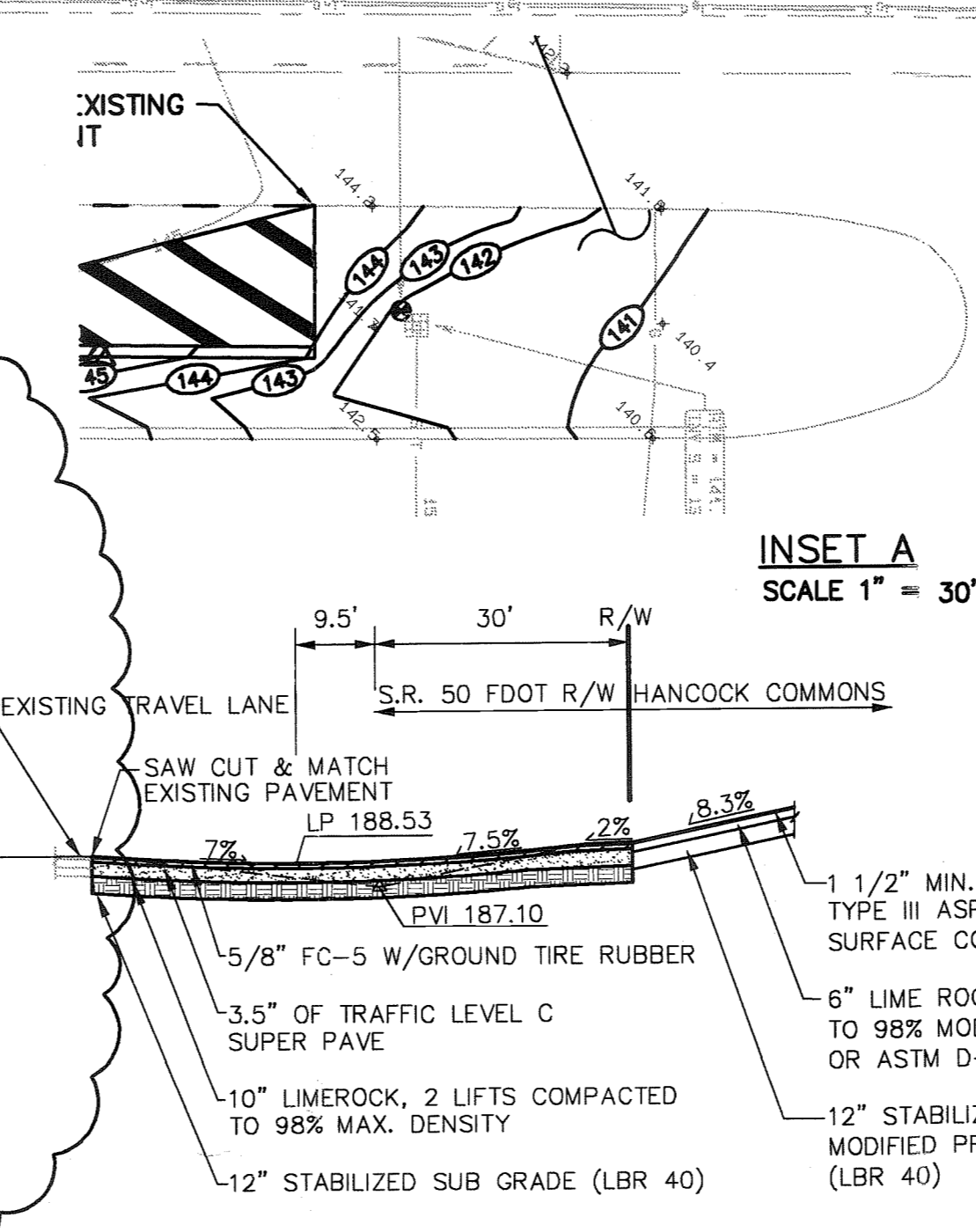
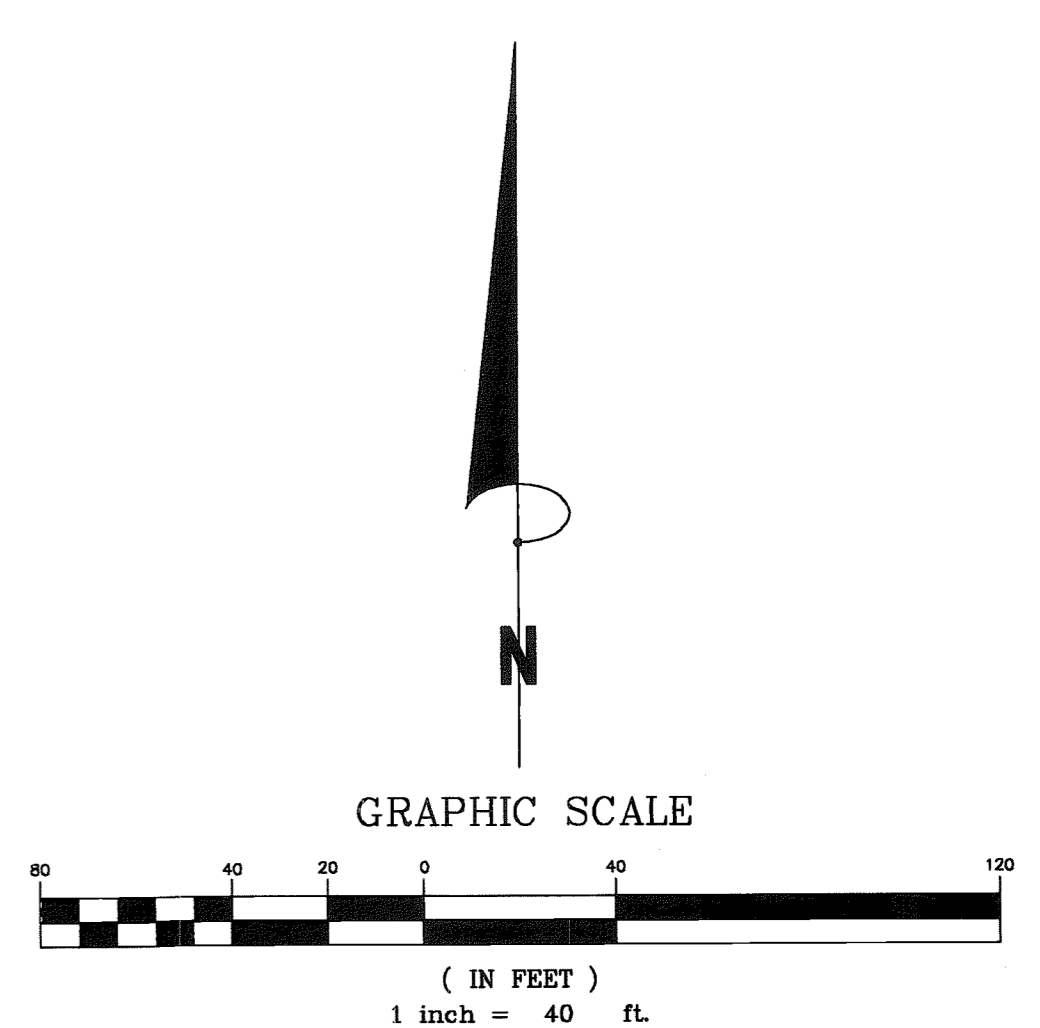
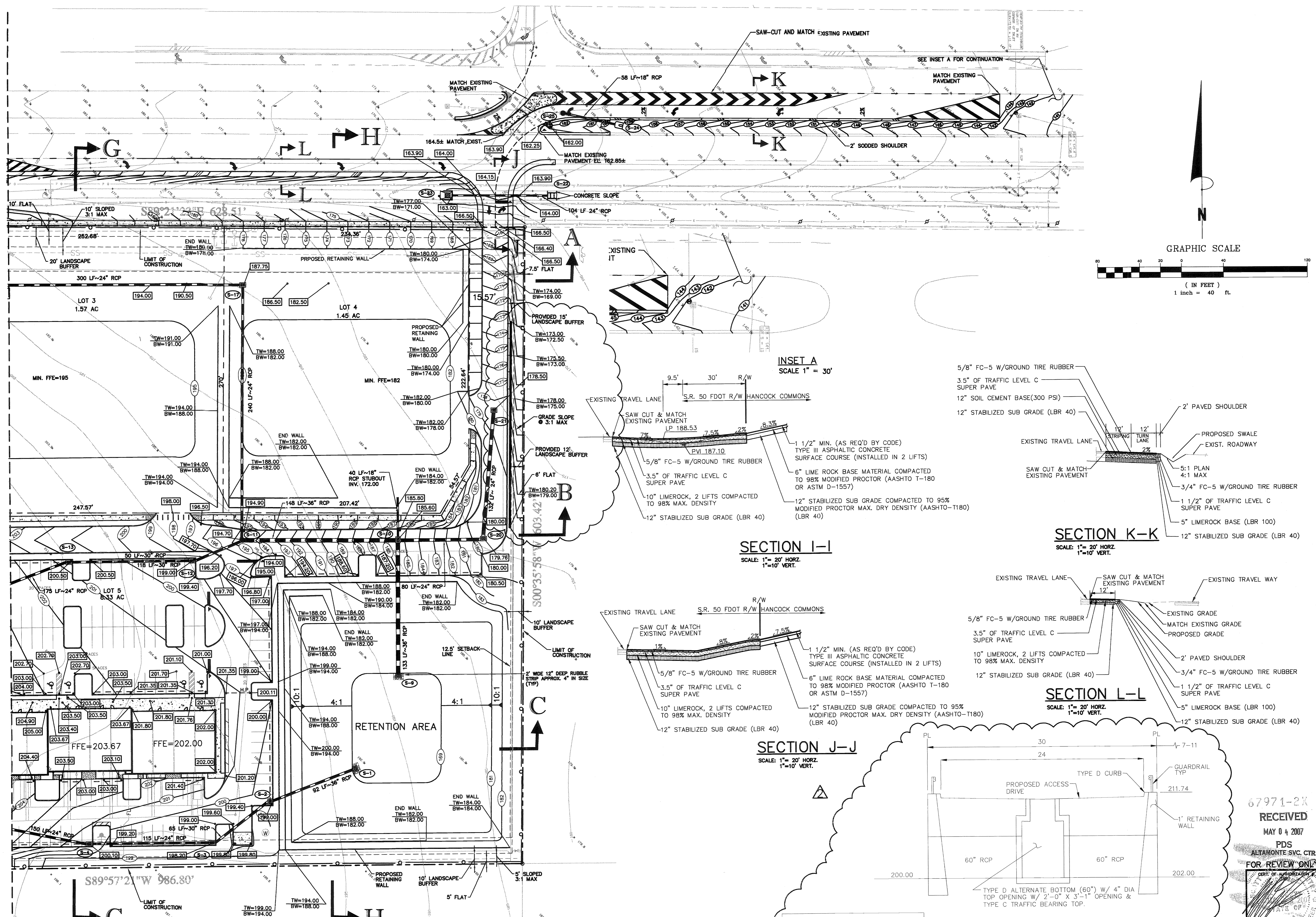

**SECTION I-I**  
SCALE: 1" = 20' HORIZ.  
1" = 10' VERT.

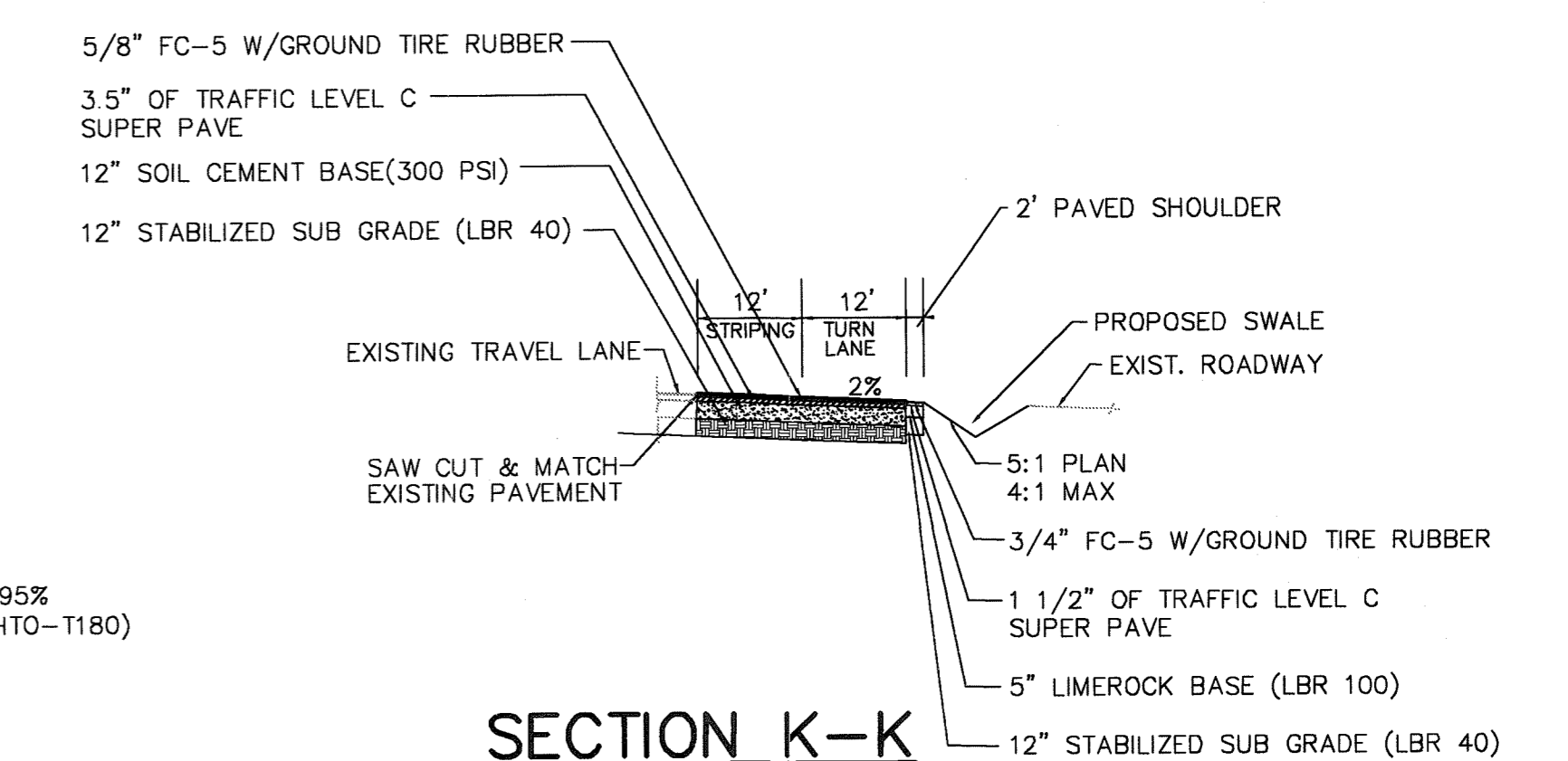

**SECTION K-K**  
SCALE: 1" = 20' HORIZ.  
1" = 10' VERT.

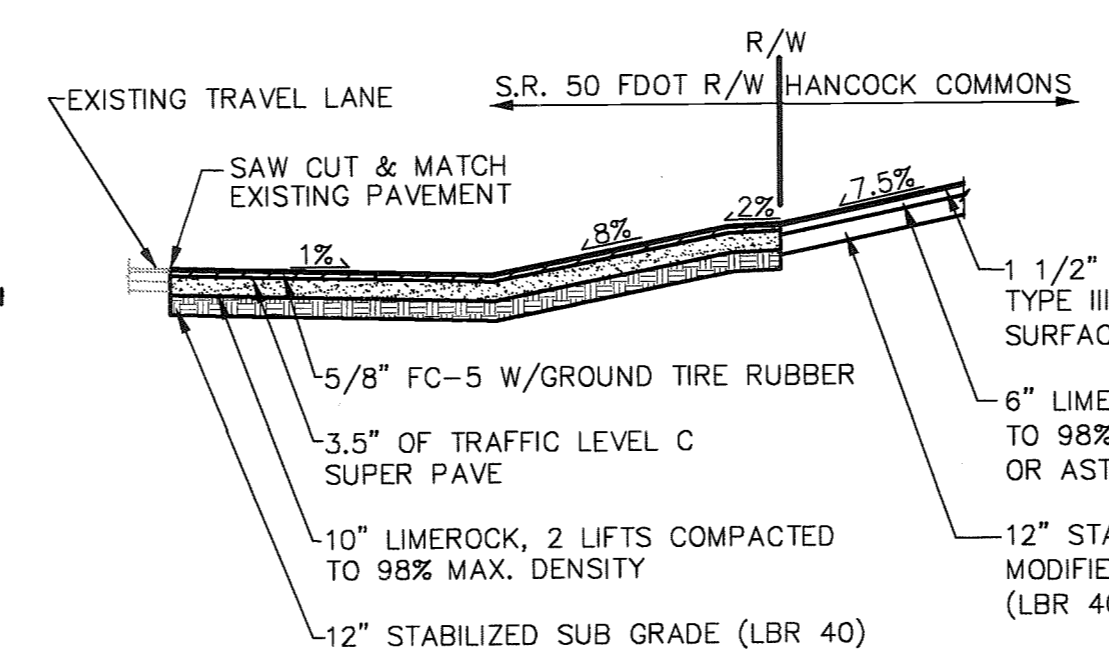

**SECTION J-J**  
SCALE: 1" = 20' HORIZ.  
1" = 10' VERT.

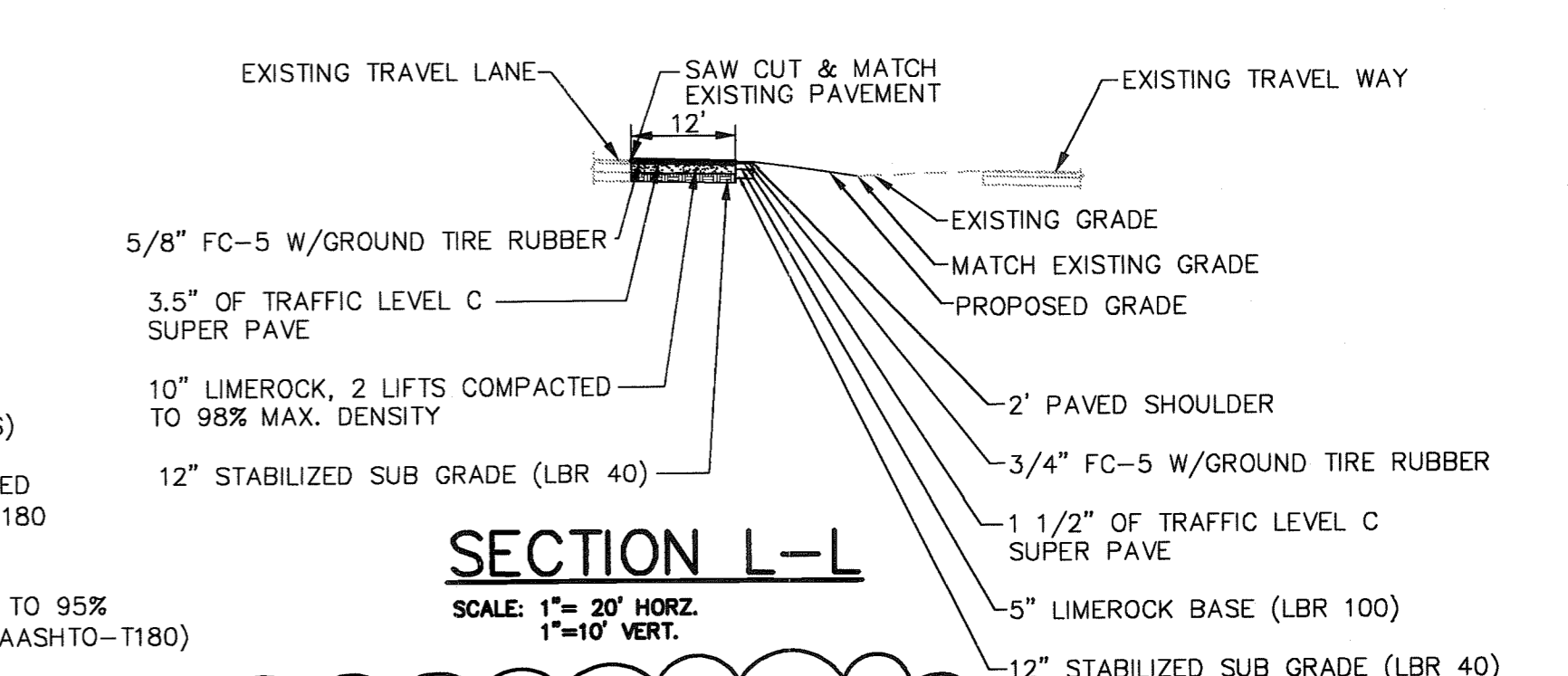

**SECTION L-L**  
SCALE: 1" = 20' HORIZ.  
1" = 10' VERT.

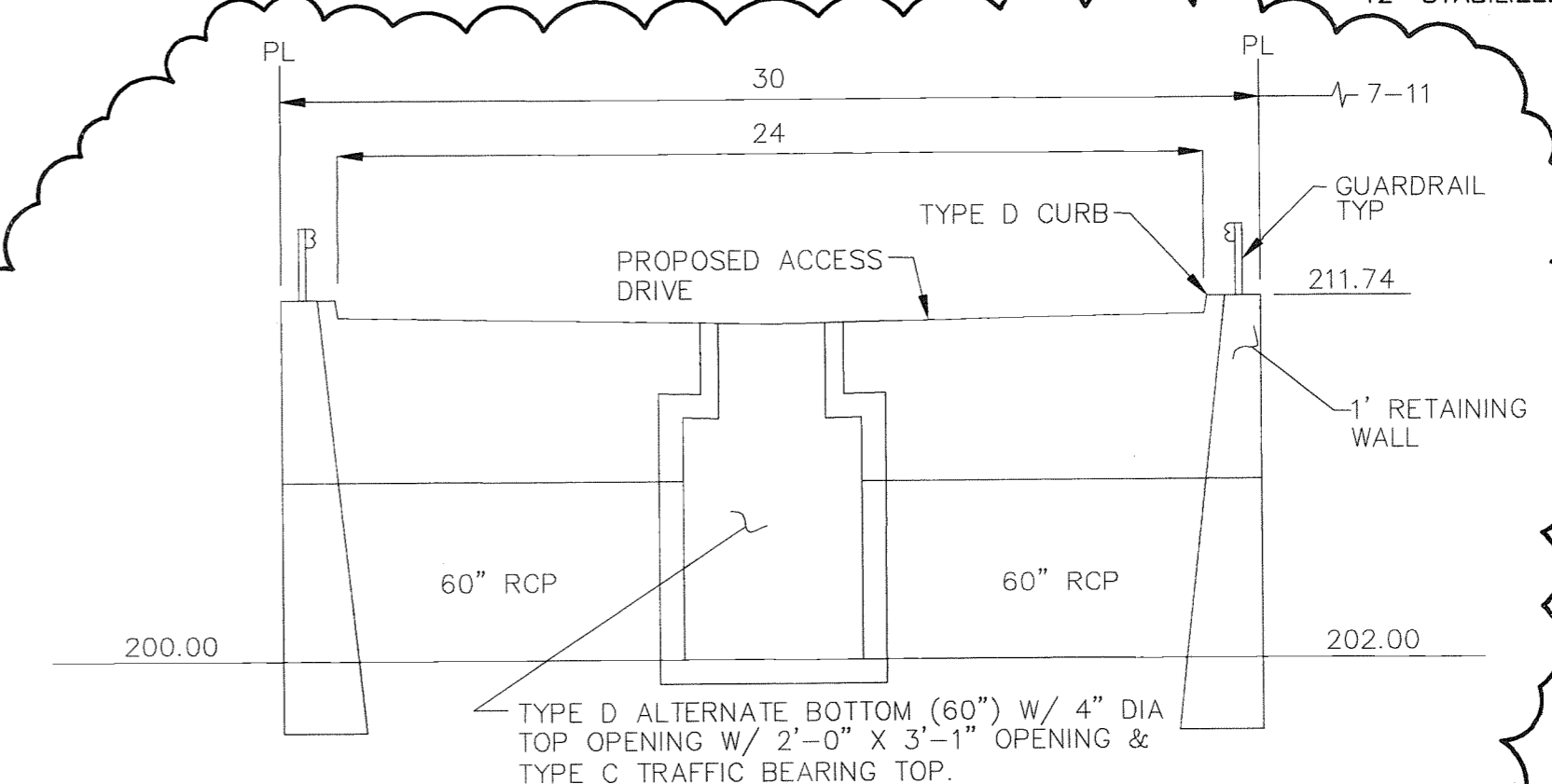

**NOTE: STRUCTURAL DESIGN BY OTHERS.**  
POND ACCESS CROSSING DETAIL (PHASE 2)  
REFER TO FDOT INDEX 250 FOR HEADWALLS  
REFER TO FDOT INDEX 232 FOR STRUCTURE

67971-2K  
**RECEIVED**  
MAY 04 2007  
PDS  
ALTA MONTE SVC. CTR.  
FOR REVIEW ONLY  
SCOTT M. GENTRY, P.E.  
FLORIDA REGISTRATION 44677  
NOT VALID FOR CONSTRUCTION  
UNLESS SIGNED IN THIS BLOCK

**KCG**  
KELLY COLLINS & GENTRY, INC.  
1740 NORTH ORANGE AVENUE, SUITE 400  
ORLANDO, FLORIDA 32804  
(407) 896-7856 FAX (407) 896-1486

PREPARED FOR:  
**TRYCON ASSOCIATES**

**HANCOCK COMMONS & CLERMONT, FLORIDA**

**PAVING, GRADING & DRAINAGE PLAN**

NO.	DATE	REVISION
1	3/30/07	ADDED WALL ELEVATIONS
2	4/17/07	REV DETAIL LABEL
3		
4		
5		

DATE: 11/08/06  
SHEET C-5